

CE

KODEN

OPERATION MANUAL

GPS/DGPS NAVIGATOR KGP-913/913D

Important Notice

Manual

Keep this manual in a safe place where you can quickly access it. This manual must be passed to any new owner of the GPS NAVIGATOR when it is transferred.

The Global Positioning System (GPS) consists of a total of 28 GPS satellites that orbit on the earth, enabling you to calculate your position anywhere in the world, 24 hours a day if you can receive satellite signals. However, these satellites are controlled by the U.S. DoD and the satellite position and speed may be changed slightly without notice due to U.S. military strategy. Also, radio emission may be interrupted due to equipment testing or adjustment or changes in their orbit, causing your positioning to fail. During actual navigation, carefully compare the calculated data with all available navigation sources such as Loran C, Decca, other navigators, charts, visual navigation, depth, water temperature and others. It is your responsibility to make navigation judgments.

About the positioning accuracy:





The GPS positioning accuracy is inhibited due to U.S. military strategy (SA). When the PDOP is 3 or less and when the GPS satellites are well positioned in orbit, you can expect 95% of positioning data in the accuracy within 100 m. The remaining 5% of data may have errors to 200 m or more. If the antenna unit is shaded, or if the satellites are not positioned well, the PDOP may drop and it is possible the 95% of positioning data may have errors exceeding 100 m.

DGPS operation note:

Your position can be improved by DGPS correction. When you are communicating with other ships, you may be using the DGPS correction position and they do not. You should advise them your position is DGPS originated.





Pictorials

This manual uses some of the following pictorials to help in the understanding of safety instructions. Always follow these instructions carefully.

| | |
|--|---|
|  WARNING | Always follow this instruction to prevent injury or lost of life. |
|  CAUTION | Follow this safety instruction to avoid personal injury or damage to your property. |
|  | Symbol "△" is a CAUTION or WARNING label describing the safety warning. (This symbol is an Electrical Shock warning label.) |
|  | Symbol "⊘" is an instruction that you must not violate. (This symbol instructs NOT to disassemble any system components.) |
|  | Symbol "●" is an operation instruction that you must follow. (This symbol indicates you must turn OFF the main power supply.) |

WARNING <For System Operators>

Always follow this instruction to prevent lost of life or injury.

| | | |
|---|---|---|
|  | Turn power OFF during abnormality. | If smoke or a burning smell occurs, fire or electrical shock may result. Turn the power switch OFF and shut down the power supply immediately. Never attempt to repair the system yourself. Call for service. |
|   | Do not open the cabinet. | High voltage exists in the instrument. Contact with it may cause personal injury or lost of life. |
|  | Do not use in poor ventilation. | If you cover this product or use in a closed place, it may malfunction or be damaged due to overheating. Use only where there is plenty of ventilation. |



Installation Cautions <For Service Personnel>

Follow the installation instructions to avoid injury and system malfunction.

| | |
|--|--|
| Installation in rigid position | Mount your system securely on a rigid frame or ceiling. Otherwise, your mounting may loosen. |
| Use correct installation materials: | Use only the installation materials in the standard accessory pack. If the bolt and screw strength is not sufficient, your unit may fall and be damaged. |
| Keep away from direct sunlight. | Keep your unit away from direct sunlight, otherwise, it may be damaged or burnt due to overheating. |
| Keep away from water. | Take care not to drop water on your system as it may become damaged or you may receive an electrical shocked. |
| Keep away from heat source. | Keep your unit away from a direct heat source as it may malfunction or burn. |
| Use correct power source. | Operate your system with the specified power voltage. Incorrect input voltage may cause damage, fire or injury. |



Maintenance Cautions <For Maintenance Personnel>

Use the following safety precautions during internal inspection.

| | |
|----------------------------------|---|
| Discharge capacitors. | A high voltage may remain in the capacitors of the high-tension circuit several minutes after you have turned the power switch off. Wait at least five minutes or discharge them to the ground before starting your inspection. |
| Check that power is OFF. | To prevent electrical shock due to erroneous power switching, make sure that the main power supply and the system power switch are both off. Also attach a safety label showing that service is in progress. |
| Avoid static electricity. | Take care not to damage the ESDs (Electrostatic Sensitive Devices) as a result of static electricity from carpet and cloths. |
| Avoid dust. | Wear a safety mask to protect against dust during inspection or cleaning inside your system. |

Operation Notes <For Operators>

Observe the following operation notes. System failure or deterioration can result. Periodic inspection and maintenance are required for maintaining the system in an optimum condition.

| | |
|-------------------------------|--|
| Backup important data. | Save or log important data in backup memory or log sheets. The initial setup data and your storage data may be lost when the internal battery expires or when you service the electrical circuits. |
| Avoid excessive force. | Take care not to apply excessive force to the display unit (LCD). Since the display panel has high-density electronics components, excessive force can crack or damage it. |

Table of Contents

| | |
|---|-----------|
| Important Notice | i |
| Understanding GPS (Global Positioning System) | 3 |
| Arrangement of GPS satellites | 3 |
| How your position is obtained? | 3 |
| Structure of GPS | 3 |
| For Proper Operation | 4 |
| GPS signal reception (HDOP or PDOP) | 4 |
| Mounting GPS receiver and notes on LCD | 4 |
| Display Unit | 5 |
| Getting Started | 6 |
| Switching screens | 7 |
| Switching the Navigation Data (OFF, WPT, RTE, or ANCW mode) | 7 |
| A (NAV1) screen in OFF mode | 8 |
| B (NAV2) screen in OFF mode | 8 |
| C (NAV3) screen in OFF mode | 8 |
| D (PLOT) screen in OFF mode | 8 |
| How to Find Out Your Position | 9 |
| Storing present position (EVENT) | 9 |
| Using MOB (Man over-board) key | 10 |
| Recalling event or MOB position | 11 |
| Displaying average speed, average bearing and elapsed time | 11 |
| How to Get Distance and Bearing to WPT | 12 |
| Navigation to WPT | 12 |
| Storing waypoints (LAT/LONG data) | 13 |
| Storing a new position or updating an existing one | 13 |
| Writing a comment | 13 |
| Copying a position | 14 |
| Changing the comment I.D. | 14 |
| Erasing a single waypoint | 14 |
| Setup of Waypoints navigation | 15 |
| Setting waypoint navigation | 15 |
| Recalling a waypoint | 15 |
| Quick WPT setup (in waypoint navigation) | 16 |
| Reentering the starting point in waypoint navigation | 16 |
| Cancelling waypoint navigation | 16 |
| B (NAV2) screen during waypoint navigation | 17 |
| C (NAV3) screen during waypoint navigation | 17 |
| D (PLOT) screen during waypoint navigation | 17 |
| Cross track error and course deviation angle | 18 |
| Navigation graph of B (NAV2) screen | 18 |
| Electronic fairway (NAV3) screen | 19 |
| Storing and Erasing Routes | 21 |
| Storing your route | 21 |
| Automatic switching of waypoints | 21 |
| Erasing point data | 22 |
| Erasing a single route | 22 |
| Route Setup | 23 |
| Selecting route navigation | 23 |
| Reentering the origin of route navigation | 23 |
| Checking a route point position | 24 |
| Skipping a route point in route navigation | 24 |
| Cancelling route navigation | 24 |
| Switching between distance and time to go | 25 |
| B (NAV2) screen during route navigation | 26 |
| C (NAV3) screen during route navigation | 26 |
| D (PLOT) screen during route navigation | 26 |
| Setting an anchor position | 27 |
| Storing an anchor position | 27 |
| Recalling the anchor position | 27 |
| Removing the anchor position symbol on PLOT screen | 27 |
| Reentering an anchor position | 27 |
| Cancelling the anchor position | 28 |
| B (NAV2) screen during anchor position setup | 28 |
| C (NAV3) screen during anchor position setup | 28 |
| D (PLOT) screen during anchor position setup | 28 |
| Alarms | 29 |
| Kinds of alarm | 29 |
| What is a GPS fix alarm? | 29 |
| What is a DGPS fix alarm? | 29 |
| What is an anchor watch alarm? | 29 |
| What is a proximity alarm? | 29 |
| What is an XTE (course deviation)? | 30 |
| What is a CDI (course deviation angle)? | 30 |
| Alarm explanation | 30 |
| Setting and cancelling | 31 |
| Track Display | 32 |
| Displaying a cross cursor on PLOT screen | 32 |
| Screen scrolling | 32 |
| Scaling the PLOT screen | 33 |
| Changing the setup contents | 33 |
| How to use LOPs | 34 |
| Initial setup for LOP display | 34 |
| Selecting LOPs (Loran C, Loran A or Decca) | 34 |
| Setting the chain and secondary stations to be displayed | 34 |
| Registering a position in LOPs | 35 |
| Storing waypoints (LOPs data) | 36 |
| Storing a new position or updating an existing one | 36 |
| Menu 5: Correcting your position (LOPs) | 37 |

| | |
|---|-----------|
| Direct entry of actual position data | 37 |
| Entry of correction amount | 39 |
| Checking the correction amount | 40 |
| Canceling position correction | 40 |
| Menu 7: Calculating LOPs based on LAT/LONG data | 41 |
| Calculating Loran C LOPs based on LAT/LONG data | 41 |
| Calculating Loran A LOPs based on LAT/LONG data | 42 |
| Calculating Decca LOPs based on LAT/LONG data | 43 |
| Setup Procedure | 44 |
| Menu options | 44 |
| Selecting a menu option | 44 |
| Menu 3 | 45 |
| Monitoring GPS satellite signal reception | 45 |
| Selecting a measuring system mode | 45 |
| Selecting a geodetic datum | 45 |
| Setting antenna height (above sea level) | 46 |
| Masking DOP | 46 |
| Masking satellite elevation angle | 46 |
| Menu 4: GPS NAVIGATOR | 47 |
| What is the differential GPS (DGPS)? | 47 |
| Displaying differential GPS (DGPS) | 47 |
| DGPS measurement | 47 |
| Selecting the DGPS input signal baud rate | 48 |
| Setting a DGPS timeout | 48 |
| Selecting a beacon station | 48 |
| DGPS monitor | 49 |
| Menu 4: DGPS NAVIGATOR | 50 |
| What is the differential GPS (DGPS)? | 50 |
| Displaying differential GPS (DGPS) | 50 |
| DGPS measurement | 50 |
| Setting a DGPS timeout | 51 |
| Selecting a beacon station | 51 |
| Storing a beacon station | 52 |
| DGPS monitor | 52 |
| Menu 5 | 53 |
| Correcting your position | 53 |
| Compensating the compass | 55 |
| Displaying local time | 56 |
| Menu 7 | 57 |
| Calculating the distance and bearing between two points | 57 |
| Calculating LOPs based on LAT/LONG data | 57 |
| Course calculation to a waypoint (boat speed, arrival time and time to go to waypoint) | 58 |
| Course calculation to a destination (boat speed, final arrival time and total navigation time) | 59 |
| Menu 8 : Initial setting | 60 |
| 1: Setting average constants (measuring position, speed and course) | 60 |
| 2: Changing the distance or speed unit | 60 |
| 3: Changing the antenna height unit | 60 |
| 4: Changing sail mode | 60 |
| 5: Displaying position data in LAT/LONG mode | 60 |
| 6: Changing the latitude and longitude display digits (between .001' and .0001') .. | 60 |
| 7: Specifying the chain and secondary stations for Loran C, Loran A or Decca | 60 |
| Menu 9 | 61 |
| Selecting an output data format : DGPS NAVIGATOR only selectable | 61 |
| Editing the NMEA-0183 output data format | 61 |
| Explanation of output data (sentence) | 61 |
| Outputting waypoint data during route navigation | 62 |
| Operation of built-in simulator | 62 |
| Initial Menu | 63 |
| 1: Initialization | 63 |
| 2: Changing the display language | 63 |
| 3: Erasing entire data from memory | 63 |
| 4: Switching between Loran C LOPs, Loran A LOPs and Decca LOPs modes | 63 |
| 5: Changing a stored method present position (EVENT) | 63 |
| 6: Selecting an initial value (North, South, East, West) of latitude/longitude | 63 |
| Troubleshooting Guide | 64 |
| Nothing appears when you press PWR/DIM key | 64 |
| The display does not change (during reset) | 64 |
| Error message appears as you power on | 64 |
| Nothing appears but buzzer sounds during power-on | 64 |
| If differential GPS (DGPS) positioning fails | 64 |
| Unstable signal reception | 65 |
| Unstable beacon signal reception | 65 |
| Replacing the fuse | 65 |
| Mounting the waterproof cap | 65 |
| Specifications | 66 |
| Major Specifications | 66 |
| Standard equipment list | 67 |
| Options | 67 |
| Outline and dimensions | 68 |
| Interconnection diagram : GPS NAVIGATOR | 69 |
| Interconnection diagram : DGPS NAVIGATOR | 70 |
| Installation Antenna | 72 |
| Selecting the best site for GPS antenna | 72 |
| Cable connections | 73 |
| Antenna installation | 73 |
| Selecting the best site for Beacon antenna with its coupler | 74 |
| RF ground | 75 |
| Receiving antenna and antenna coupler installation | 76 |
| Local Geodetic System | 77 |

Understanding GPS (Global Positioning System)

Arrangement of GPS satellites

GPS is a navigation system using 24 satellites (21 plus 3 in reserve) orbiting 20,183 km high from the earth every 11 hours 58 minutes.

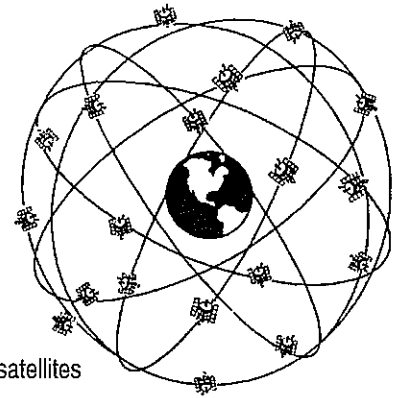

Arrangement of GPS satellites

How your position is obtained?

Your position is determined by calculating the distance from two satellites (in 2-dimensional positioning) or three satellites (in 3-dimensional positioning) to your position. The distance is determined by the time taken for a message to be sent from the satellites to the receiver. However, an additional satellite is used to eliminate measuring errors resulting from the time factor since it is not practical to have a clock synchronized precisely with the clocks on the satellites.

In 2-dimensional positioning, your position (latitude and longitude; height is preset) is determined at the intersection point of three spheres formed by three satellites. In 3-dimensional positioning, your position (latitude, longitude and height) is determined at the intersection point of four spheres formed by four satellites.

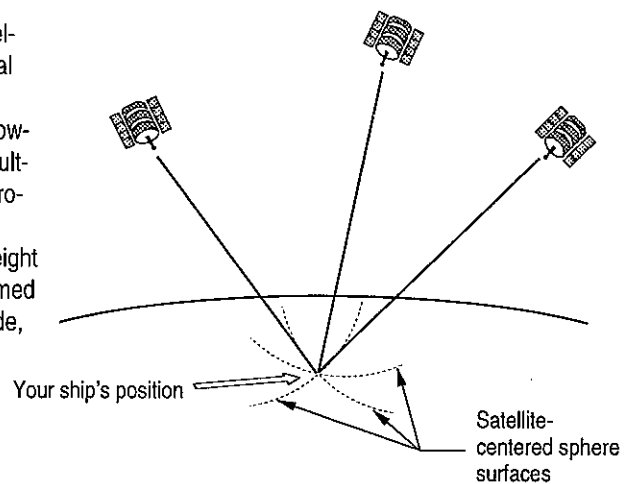

Notes:

1. The accuracy of measurement by GPS may be subject to change by the policy of the U.S. Department of Defense (DoD).
2. The GPS system is based on a geodetic system called WGS-84. In conventional world map system, one coordinate system differs from others with region, and this causes the position fix made on the map and GPS measurement to differ to a certain extent. For further information, see "Selecting a geodetic datum" on Page 45 and "Correction your position" on Page 37 to 40 and Page 53 to 54.

Structure of GPS

- Space segment
24 satellites (6 orbits \times 4 satellites)
- Control segment
The control station that monitors and controls GPS satellites from the earth.
- User segment
GPS receiver owned by users.

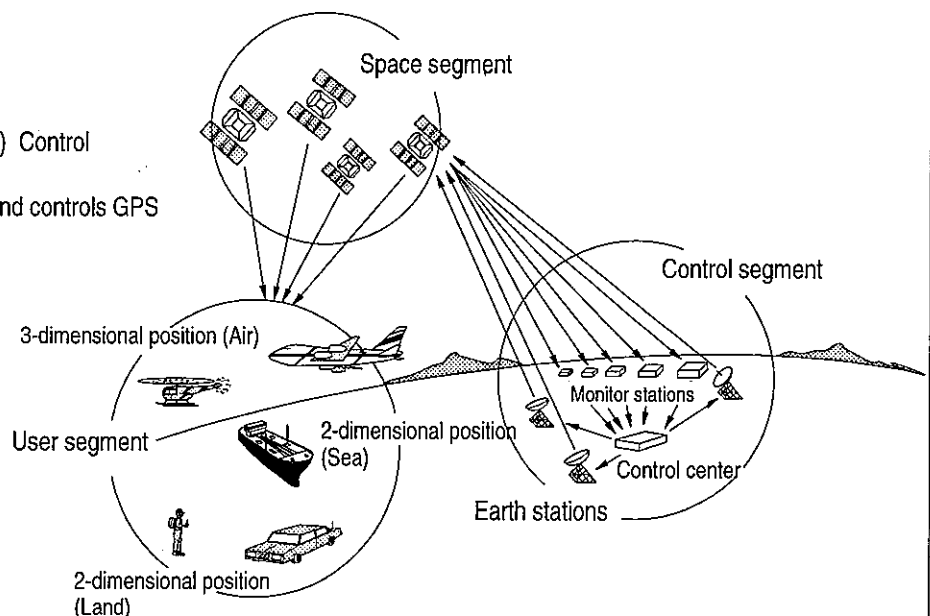

For Proper Operation

GPS signal reception (HDOP or PDOP)

The accuracy of position determination with GPS is affected by the geometrical position of satellites and the accuracy of the ranging to the satellite.

- The satellite geometrical position in comparison to the user is expressed in the Geometrical Dilution of Precision, GDOP (or DOP). Roughly speaking, the more "spread out" the satellites are, the better accuracy of the position. When the satellites are bunched together, the position may not be as accurate as normal.
- GPS receiver usually employs an algorithm which selects satellites based on the lowest DOP in accordance with satellites moving.
- Horizontal DOP (HDOP) is for the horizontal (LAT/LONG) aspect of the error: two-dimensional navigation.
- Position DOP (PDOP) is for both horizontal (LAT/LONG) and vertical (altitude) aspect of error: three-dimensional navigation.

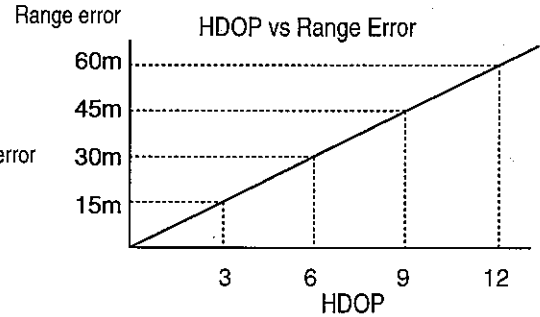
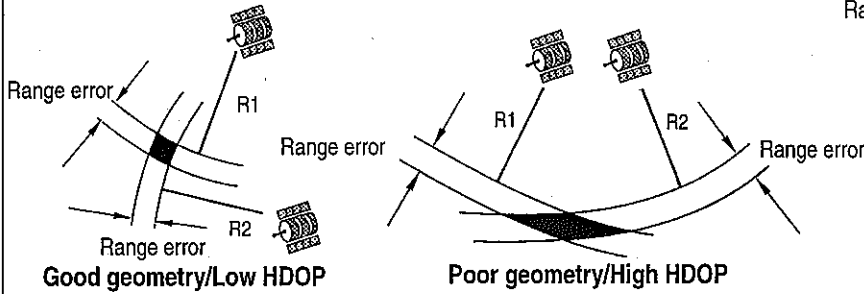

Notes:

Horizontal position uncertainty

- The two-dimensional measurement may have a dropped accuracy in horizontal direction (about an error multiplied by HDOP) if your altitude differs from the antenna height you have entered.
- The value of DOP changes with time because all satellites move in orbit. As a result, even if the GPS receiver is fixed to a certain point, the value measured by the geometrical position is not fixed at all times.
- When satellites are positioned near the horizon (lower elevation), you cannot receive GPS signals due to interruption by mountains, buildings, etc.
- GPS signals cannot be received in a room. Place the antenna in an open site, away from obstacles.
- The bearing data obtained from the GPS navigation system is a reference from the true north.

It takes more time to fix position when:

- You use your GPS receiver for the first time.
- The stored orbital data is not suitable for the available satellite, or purged due to lengthy storage.
- You use it after moving a long distance.

NAVIGATOR shortens position calculating time by storing the orbital data sent from the available satellites. When you first switch on the receiver, it may take about 15 minutes before the first fix is made.

From the second operation, the receiver can fix your position within a minute because of stored satellite data from the previous operation.

Mounting GPS receiver and notes on LCD

Read and follow the Important Notice given at the beginning of this manual for operations.

If your NAVIGATOR is damaged or out of order, please contact your local agent or authorized dealer for service.

Special notes for LCD (Liquid Crystal Display) panel

- Avoid the following conditions to insure good LCD visibility:
 - Long-time exposure to direct sun rays or UV.
 - Extremely hot (surrounding temperature above 50 °C or 120 °F) or cold (below 0 °C or 32 °F) environment. The character switching speed can slow in low temperatures (however, this is not a fault as it becomes normal in warm temperature).
- Extremely high humidity. The LCD can show poor performance or can be damaged.

Display Unit

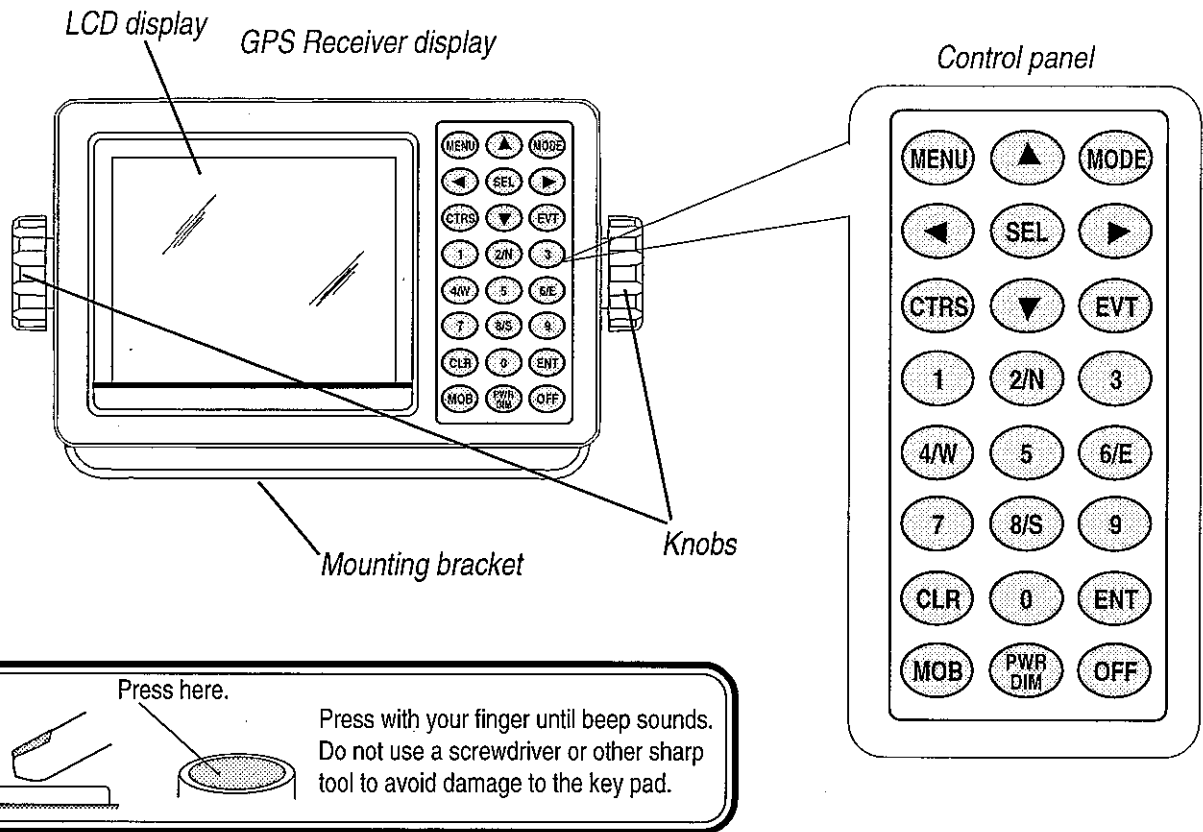

| | | | |
|--|---|--|---|
| | Mode Selects NAV1 (Navigation-1), NAV2, NAV3 or PLOT (Plotter) screen. | | Emergency Activates MOB (Man Over Board) function. |
| | Menu Recalls the menu. | | Power/dimmer Turns the power on and changes the brightness of control panel (4 levels). |
| | Clear Clears numeric/optional parameter or stops alarm sound temporarily. | | Power-Off Turns the power off. |
| | Enter Enters a numeric/optional parameter. | | Numeric Recalls memory position, entry of numerical values, and selection North or South latitude or East or West longitude. |
| | Event Stores event positions. | | Cursor shift Shifts the cursor in direction of the respective key on the screen when you select an option or enter a numeric value. |
| | Contrast Changes display contrast in 8 levels. | | |
| | Selection Selects parameters. | | |

Getting Started

NAVIGATOR shortens position calculating time by continuously updating data sent from available satellites. (When no orbit data is stored, this is called the initialized condition.) When you first turn on the receiver and if no orbit data is stored, it will take about 15 minutes until the first fix is made. Once this is completed, time to position fix is much quicker. (1-2 minutes)

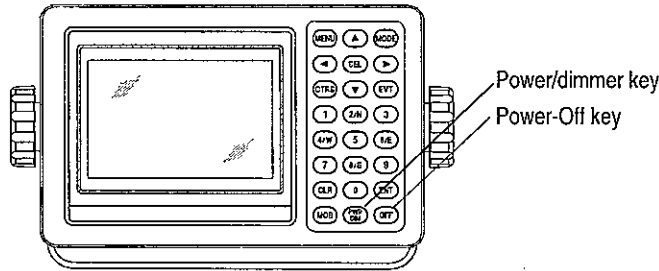

On-screen messages change in the following sequence when NAVIGATOR receives satellite signals and the latitude/longitude is displayed.

PWR DIM Press to power on.

Dim/bright the display:

PWR DIM Press to dim/bright the screen.

Change the contrast:

CTRS Press to change the LCD contrast (intensity) in 8 levels.

Power off:

OFF Press for 2 seconds to turn NAVIGATOR off. All data before power-off is kept in memory for later use.

What is failure of positioning?

If signals from three or more satellites are not received, your position cannot be calculated.

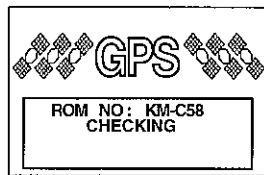

Initial message during power-on

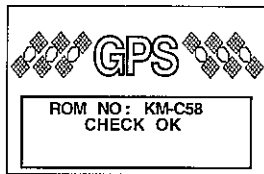

Message to indicate checking of GPS receiver and display has been completed.

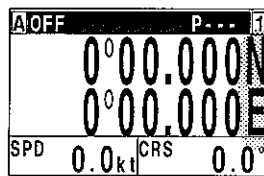

Blinks when NAVIGATOR is searching GPS satellites.

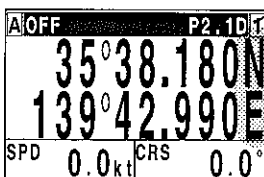

When NAVIGATOR receives signals from 3 or more satellites, it displays present latitude and longitude position with solid N (or S) and W (or E).

Switching screens

Press the SEL key to scroll the screen sequentially.

A: NAV1 screen

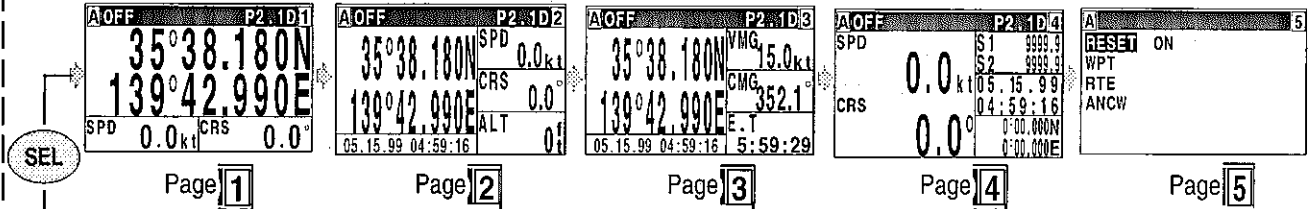

B: NAV2 screen

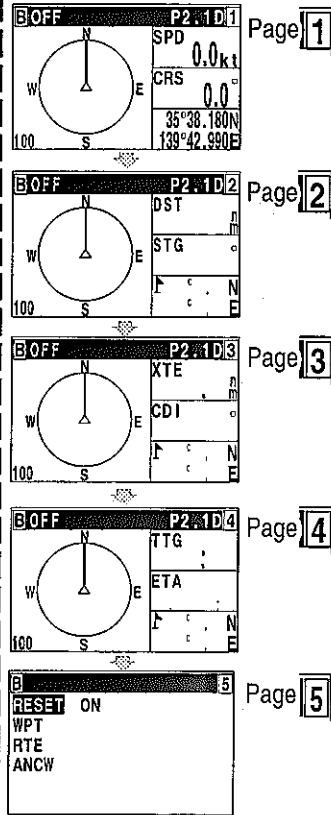

D: PLOT screen

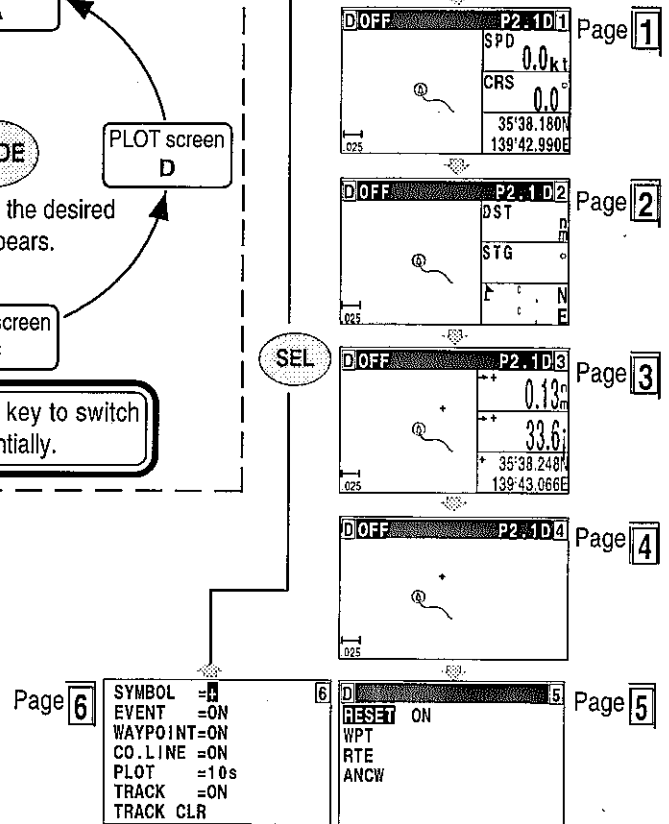

C: NAV3 screen

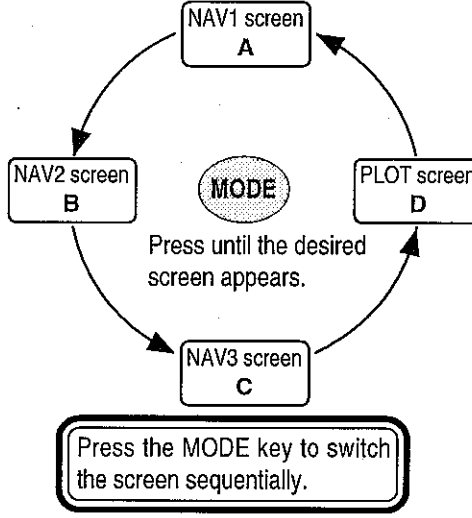
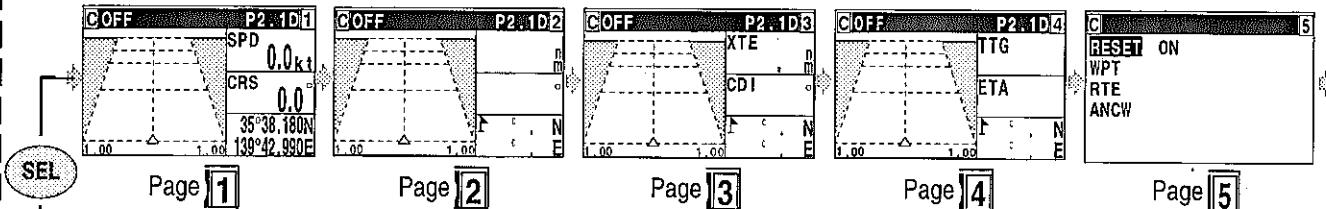

- A (NAV1) screen: Indicates your present position as numerical data.
- B (NAV2) screen: Displays a bearing circle (with your boat positioned at the graph center). It shows the bearing, course, deviation, distance and cross track error from the waypoint.
- C (NAV3) screen: Shows a 3-dimensional view indicating the distance, course, cross track error, and deviation from the waypoint.
- D (PLOT) screen: Indicates the track of your boat, your present position, waypoint, and memory position.

Switching the Navigation Data (OFF, WPT, RTE, or ANCW mode)

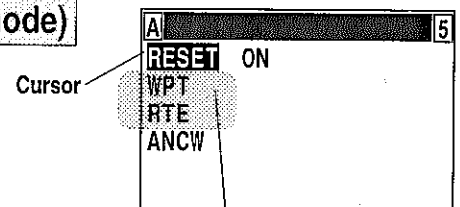
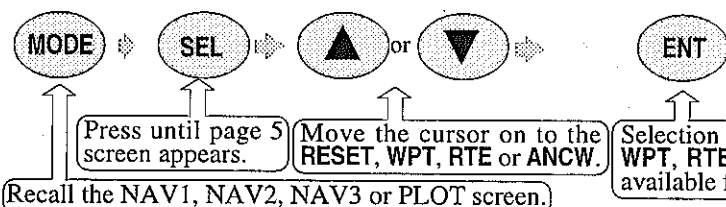

Before selecting the WPT (waypoint navigation) or RTE (route navigation), you need to register a desired waypoint or route.

A (NAV1) screen in OFF mode

See "Switching Screens" (page 7).

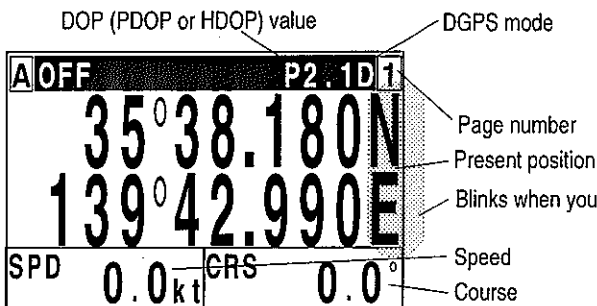

DOP (PDOP or HDOP) value

See "GPS signal reception (HDOP or PDOP)" (page 4).

DGPS mode

See "Menu 4" (page 47, 50).

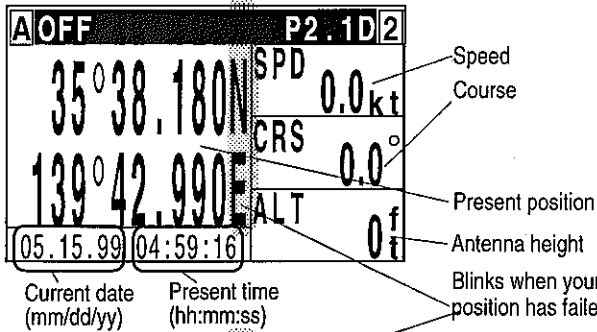

Your present position

- LAT/LONG is displayed, when displaying position data in Loran C, Loran A or Decca LOPs mode.
- Loran C, Loran A or Decca LOPs is displayed, when displaying position data in LAT/LONG mode.

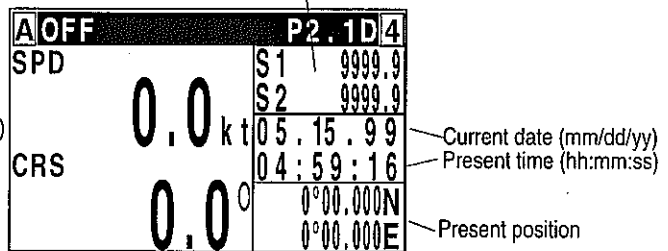
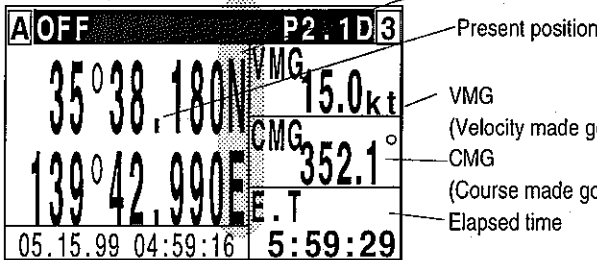

B (NAV2) screen in OFF mode

C (NAV3) screen in OFF mode

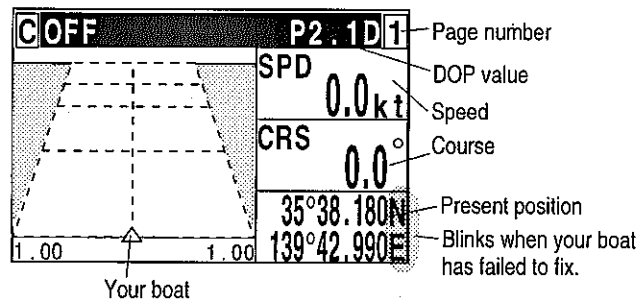
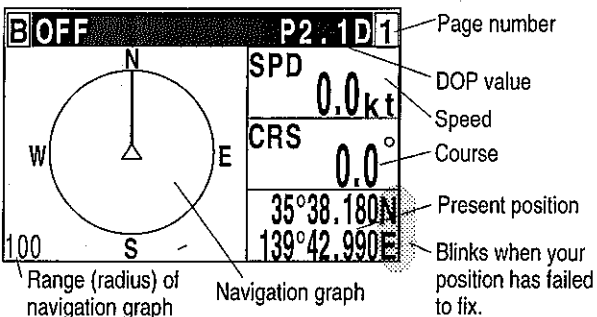

The navigation graph shows your boat position and the relative bearing.

NAV3 screen shows a 3-dimensional view indicating the distance, course, cross track error, and deviation from the waypoint. The boat icon does not move in OFF mode.

D (PLOT) screen in OFF mode

Close-up of PLOT screen

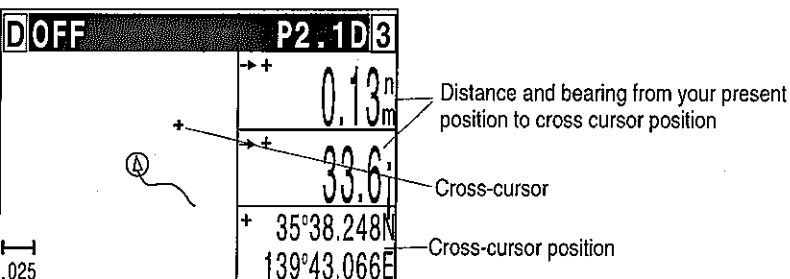
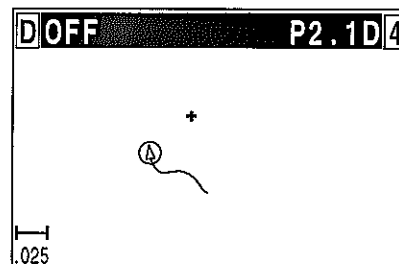
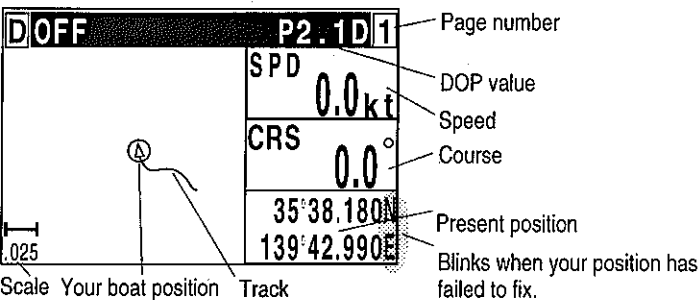

How to Find Out Your Position

You can determine your position by simply reading the present latitude/longitude and LOPs on the screen.

MODE

Press this key to recall A(NAV1), B(NAV2), B(NAV3) or D(PLOT) screen.



Caution

If position fix has failed:

If NAVIGATOR cannot receive signals from GPS satellites, it dead-reckons your position based on the calculated speed and course data. If signal interruption continues more than 2 minutes, it shows speed of zero (0) but keeps the last LAT/LONG and course data. If you have set "1:AVERAGE" option of "8:INITIAL" to "1", dead-reckoning is not used.

A(NAV1) screen

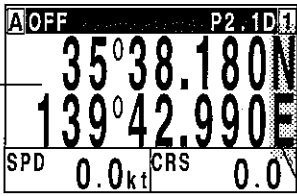

Present position

B(NAV2) screen

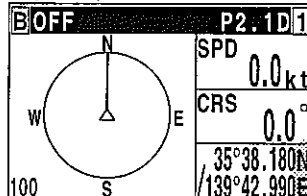

Present position

C(NAV3) screen

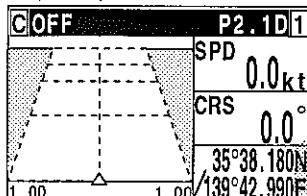

Present position

D(PLOT) screen

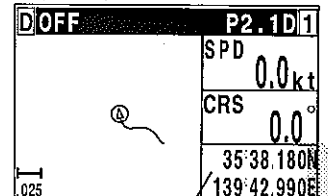

Present position

Blinks when position fix is unavailable.

Blinking information

During LAT/LONG mode: Letters N (or S) and E (or W) blink.
 During Loran C LOP mode: Letters S1 and S2 blink.
 During Loran A LOP mode: Letters S1 and S2 blink.
 During Decca LOP mode: Letter R, G or P blinks.

- Present position can also be shown in Loran C LOP, Loran A LOP or Decca LOP coordinates. See "How to use LOP" (page 34).
- Speed can be shown in different units. See "Changing the distance or speed unit" (Page 60).

Storing present position (EVENT)

You can store up to 199 present positions with numbers 001 to 199. When you store additional positions, the oldest position is deleted and the newest position is stored in its place.

- The storage date, hours and minutes, position data, and symbols (selectable on the PLOT screen) can be stored.
- It is convenient to store the present position for use later in route navigation.
- These positions can be used as targets or waypoints.
- Event numbering is available both in the automatic or manual mode. Registration of events is done from the "5. EVENT" in the INITIAL MENU.

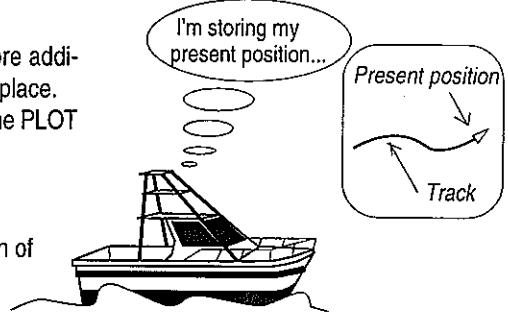

AUTO

EVT



Caution EVT key does not function when positioning is invalid.

Press EVT (Event) key to store your present position. You can store up to 199 present positions by pressing this key. They have storage numbers 001 to 199.

EVT key is valid in all screens (it has the highest operation priority). When you press EVT key on Menu, it returns to the previous screen. To recall the Menu, press MENU key again. You can also use the MOB (Emergency) key to store present positions.

Event number (001 to 199)

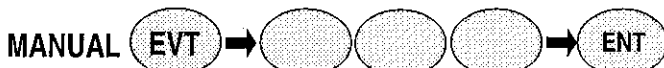

Press this key to show the registration number display window.

Specify a desired registration number from the numerical keypad.

The event will be registered to the number specified.

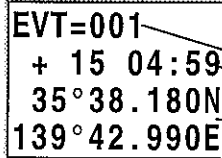

Blinks for 10 seconds.
 The latest event number
 Storage date (Day, Hour, Minute)
 Storage position (Lat, Long)

Changing the event symbols

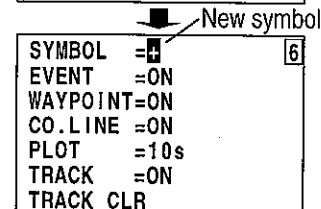
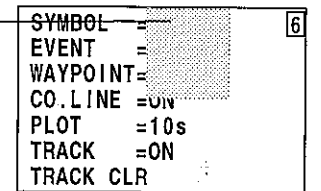
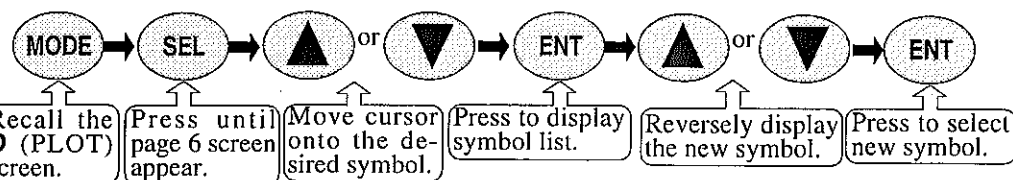

Using MOB (Man over-board) key

MOB function is provided for an emergency situation (if a person falls into the water) to make it easier to return to MOB point.



Caution

MOB key does not function if positioning is interrupted.

MOB

Press MOB key, and your position is stored immediately and MOB screen appears. You can see the distance and bearing from your present position to the point you pressed MOB key.

To change a display page: **SEL** Press until the desired page appears.

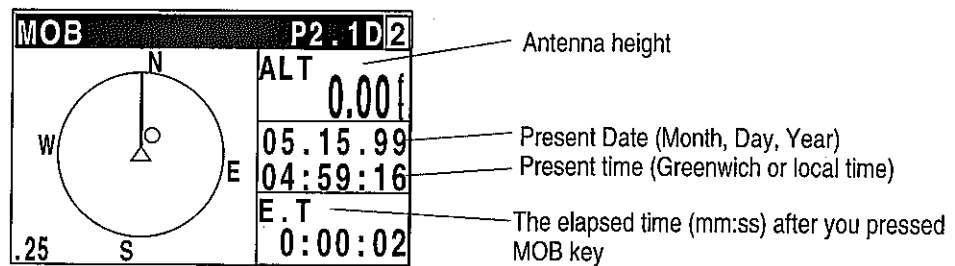
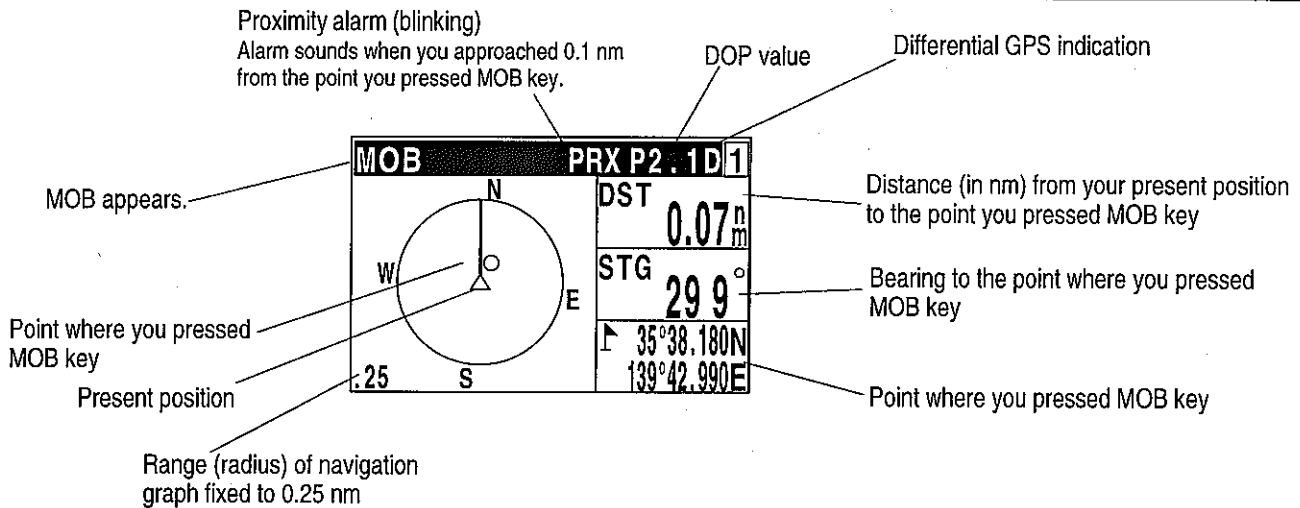

99:99

The time display that is shown when the elapsed time has exceeded 99 minutes 59 seconds after the MOB key was pressed.

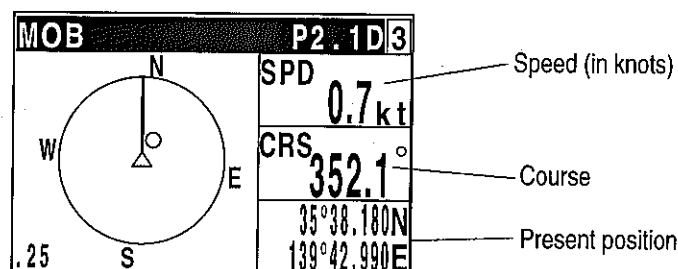

CLR

Clears the MOB mode, and returns to the previous screen when you pressed MOB key. When alarm is sounding, press CLR key to stop it. Press it again to return to the screen you were at before you pressed MOB key.

You can use only the following five keys in MOB mode:



Recalling event or MOB position

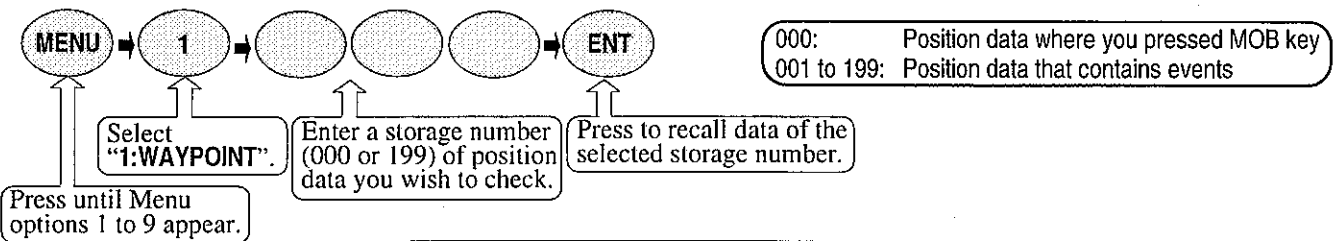

CLR Use this key if you have entered an incorrect number. You can reenter an event number.

LAT/LONG mode (Example)

| MENU | |
|------------|-------------|
| 1:WAYPOINT | 6:ALARM |
| 2:ROUTE | 7:CALCLATE |
| 3:GPS | 8:INIT.SET |
| 4:DGPS | 9:INTERFACE |
| 5:COMP | |

| 1:WAYPOINT | |
|------------|----------------|
| WPT | 000 ○ 05 04:59 |
| | 35°38.180N |
| | 139°42.990E |
| [COPY] | 001 = |
| | ○ |
| | N |
| | E |

Data displayed when you press MOB key:
Symbol (○:Fixed), storage date, storage time
Storage position

Data displayed when you press EVT key:
Symbol, storage date, storage time
Storage position

Displaying average speed, average bearing and elapsed time

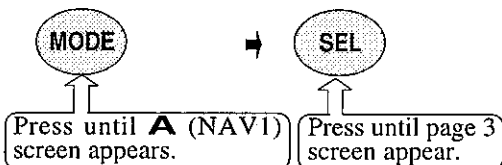

This display is also available in WPT, RTE and ANCW modes.

This function is also available even when the waypoint navigation, root navigation or anchor position is in operation.

| A OFF | P2.1D3 |
|-------------------|-------------|
| 35°38.180N | VMG 15.0kt |
| 139°42.990E | CMG 352.1° |
| 05.15.99 04:59:16 | E.T 5:59:29 |

Velocity made good (Example: 15.0 knots)

Course made good (Example: 352.1°)

Elapsed time (Example: 05 hours 59 min 29 sec)

What are velocity made good, course made good, and elapsed time?

Velocity made good: Speed that is calculated by dividing the distance between the origin (the point where you set the elapsed time) and the present position by the elapsed time.

Course made good: A true bearing from origin to present position.

Elapsed time: The time elapsed after your power-on or after you have pressed the CLR (Reset) key.

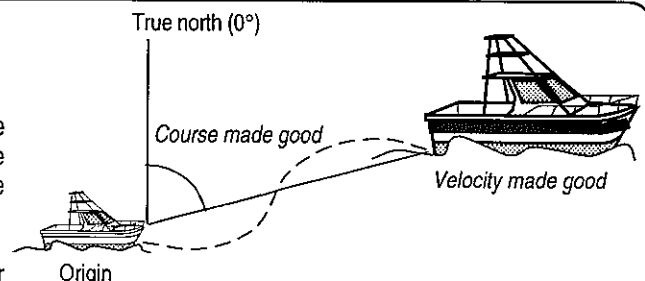

How to Get Distance and Bearing to WPT

You can obtain the following navigation information to the waypoint (WPT):

- Distance and bearing from present position to a WPT or the final destination
- Ship's speed and time to go

You can store up to 399 points (numbers 001 to 399).

Event number: 001 to 199

Waypoint number: 200 to 399

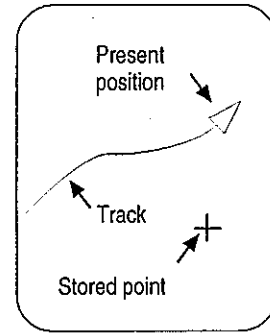
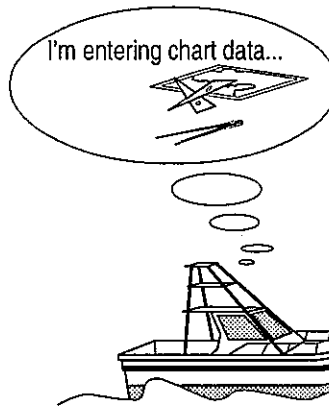

Navigation to WPT

Use the following steps (see Page 13 for operation details).

Preparation:

| | Waypoint navigation | Route navigation |
|----|---|---|
| 1. | Determine your waypoints and/or final destination from sea charts or other sources. | |
| 2. | Store latitude and longitude data of waypoints from Menu 1. | |
| 3. | N.A. | Create a route by combining waypoints and events and store the route from MENU 2 "1: ROUTE" option. |
| 4. | Check the positions on Store screen, and correct them if necessary. | Check the waypoints on Store screen, and correct if them necessary. |
| 5. | Start waypoint navigation. | Start route navigation. |

Waypoint navigation

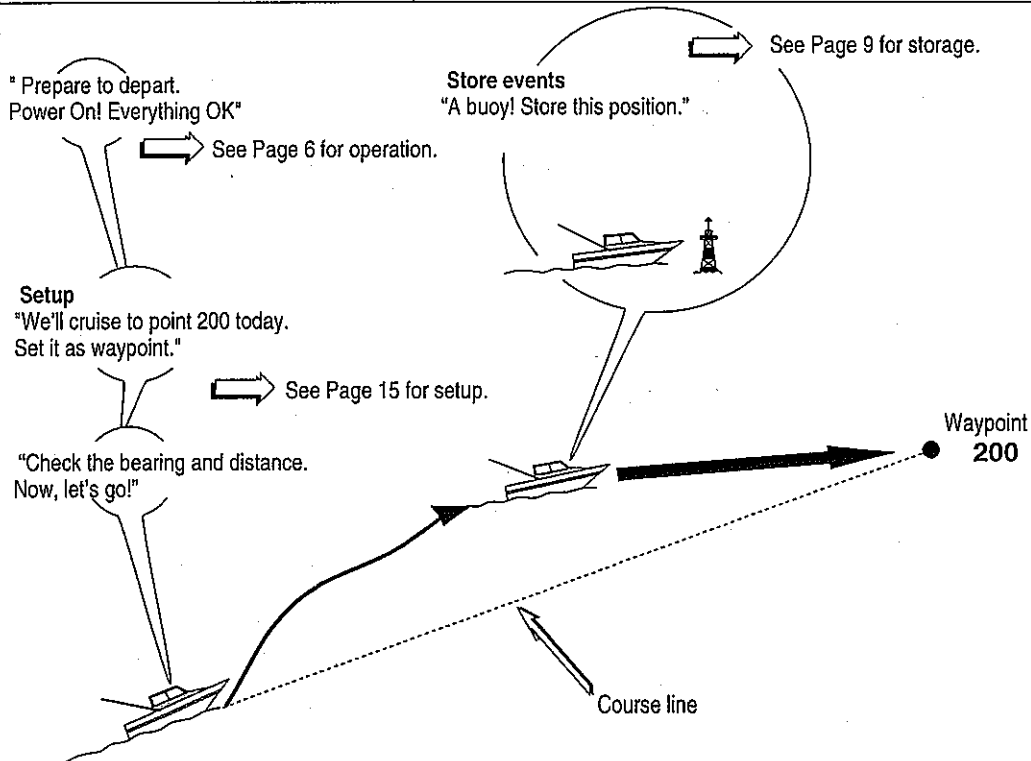

Route navigation

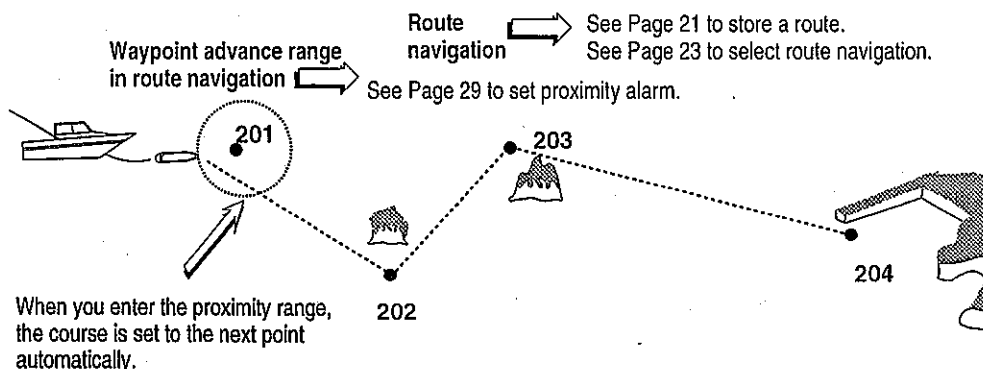

Storing waypoints (LAT/LONG) data

Storing a new position or updating an existing one

Up to 200 waypoints can be stored in memory. As 200 points (numbers 000 and 199) are reserved for MOB and event registration, you can use 200 to 399 (total of 200 points) to store waypoints.

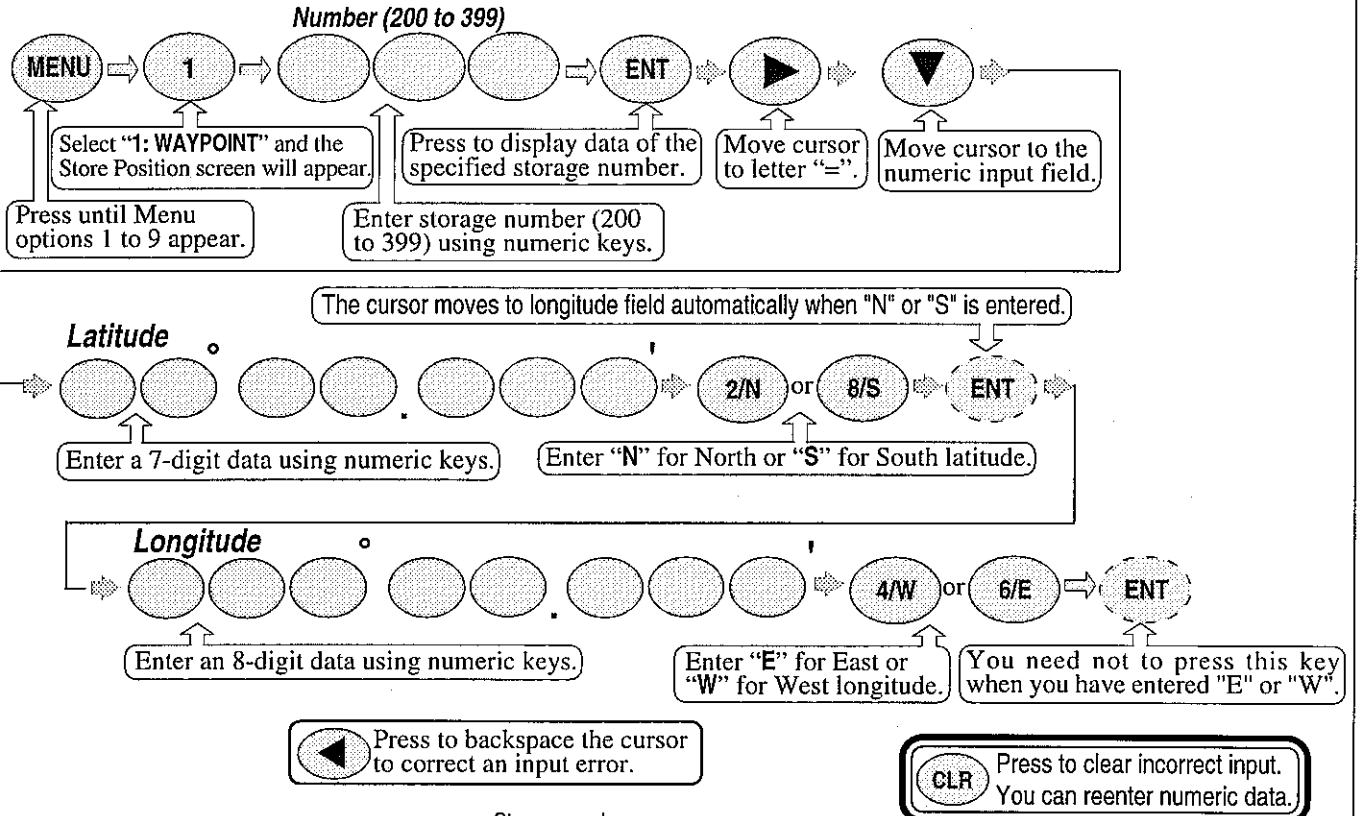

LAT/LONG mode (Example)

| | |
|------------|-------------|
| MENU | |
| 1:WAYPOINT | 6:ALARM |
| 2:ROUTE | 7:CALCLATE |
| 3:GPS | 8:INIT.SET |
| 4:DGPS | 9:INTERFACE |
| 5:COMP | |

Storagenumber

| | |
|-------------|-------|
| 1:WAYPOINT | |
| WPT | 000= |
| | ° . N |
| | ° . E |
| [COPY] 001= | |
| | ° . N |
| | ° . E |

| | |
|-------------|-------------|
| 1:WAYPOINT | |
| WPT | 200= |
| | 35°38.145N |
| | 139°43.280E |
| [COPY] 201= | |
| | ° . N |
| | ° . E |

Storage position
Latitude
Longitude

Writing a comment

Try to use comments to recall positions you often use. Nine symbols are available to use. If you set a symbol at the beginning of your comment, the symbol is shown at waypoint. If not, an asterisk (*) and waypoint number are shown on PLOT screen.

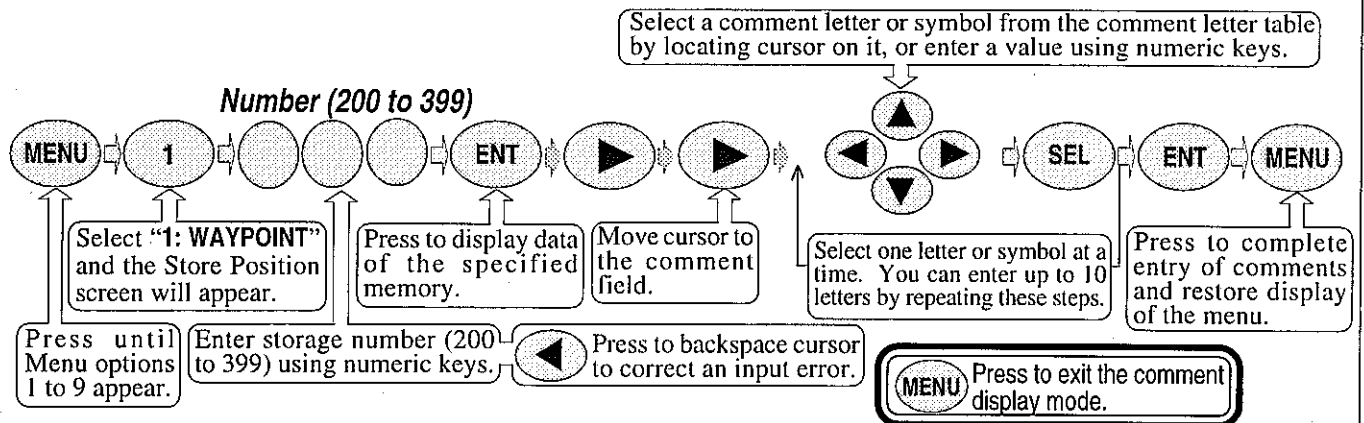

LAT/LONG mode (Example)

| | |
|------------|-------------|
| MENU | |
| 1:WAYPOINT | 6:ALARM |
| 2:ROUTE | 7:CALCLATE |
| 3:GPS | 8:INIT.SET |
| 4:DGPS | 9:INTERFACE |
| 5:COMP | |

Point number

| | |
|-------------|-------|
| 1:WAYPOINT | |
| WPT | 000= |
| | ° . N |
| | ° . E |
| [COPY] 001= | |
| | ° . N |
| | ° . E |

Table of comment letters and symbols

| | |
|-------------|-------------|
| 1:WAYPOINT | |
| WPT | 200= |
| | 35°38.145N |
| | 139°43.280E |
| [COPY] 201= | |
| | ° . N |
| | ° . E |

Example of symbols:

- ◇ + : Reference point
- ◇ : Fishing spot
- ⊥ : Shallow
- ⊥ : Sunken ships
- ⊥ : Buoy
- ⊥ : Anchoring point or other ships
- ⊥ : Prohibited area
- ⊥ : Fish gathering place

Copying a position

You can copy the position data (stored with numbers 000 to 399) to the waypoint data (having numbers 200 to 399).

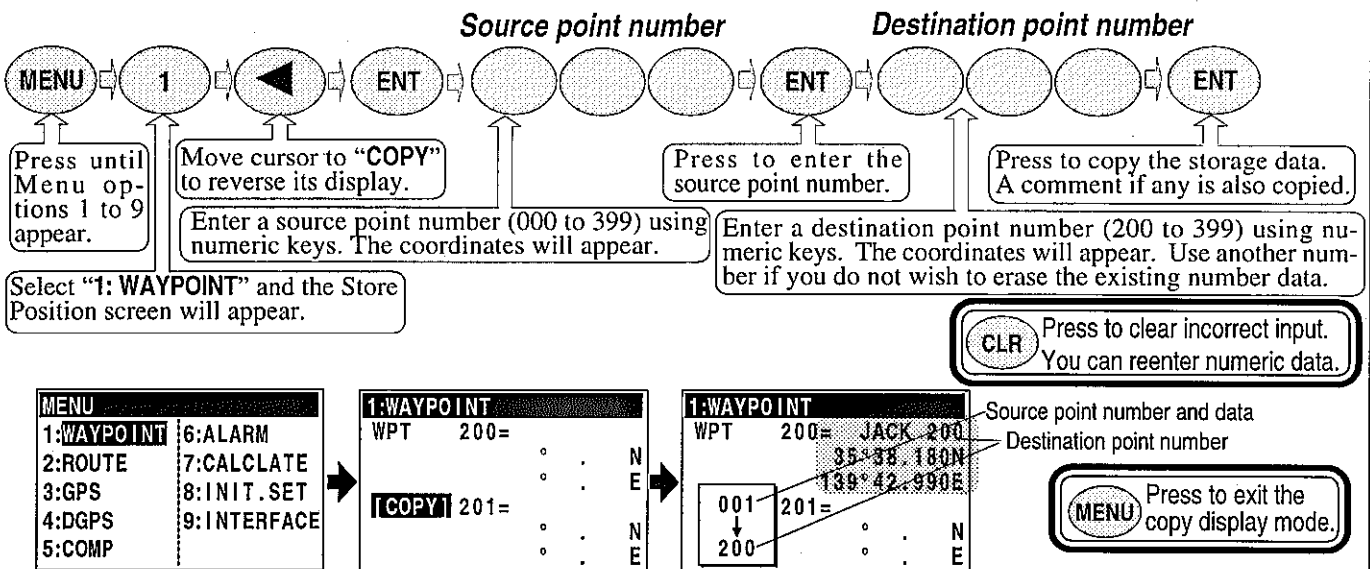

Changing the comment I.D.

You can change a comment stored in memory.

Select a comment letter or symbol from the comment letter table by locating cursor on it, or enter a value using numeric keys.

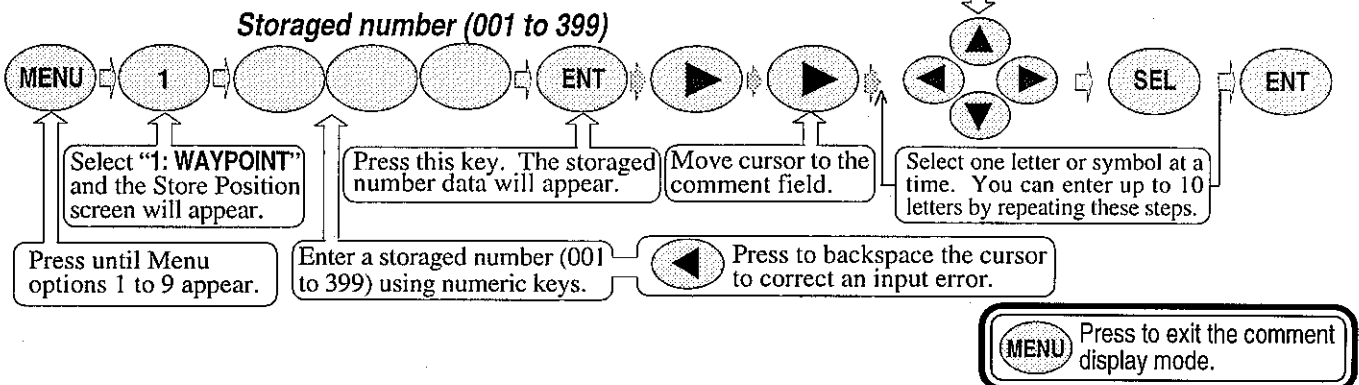

LAT/LONG mode (Example)

| | | |
|-------------|-------------------|----------------|
| MENU | 1:WAYPOINT | 6:ALARM |
| 2:ROUTE | 7:CALCLATE | |
| 3:GPS | 8:INIT.SET | |
| 4:DGPS | 9:INTERFACE | |
| 5:COMP | | |

Storage number

| | | | | | | | | | | |
|-------------------|-------------|--|--|--|--|--|--|--|--|--|
| 1:WAYPOINT | WPT 000= | | | | | | | | | |
| | [COPY] 001= | | | | | | | | | |
| | | | | | | | | | | |
| | | | | | | | | | | |
| | | | | | | | | | | |

Comment letter and symbol table

| | | | | | | | | | | |
|-------------------|----------|--|--|--|--|--|--|--|--|--|
| 1:WAYPOINT | WPT 200= | | | | | | | | | |
| | | | | | | | | | | |
| | | | | | | | | | | |
| | | | | | | | | | | |
| | | | | | | | | | | |

Comment field

Changed comment

| | | |
|-------------------|-------------|-------------|
| 1:WAYPOINT | WPT 200= | JAC 200 |
| | | 35°38.145N |
| | | 139°43.280E |
| | [COPY] 201= | |
| | | |
| | | |
| | | |
| | | |

Erasing a single waypoint

Data with number 000 is reserved for MOB. You cannot erase it.

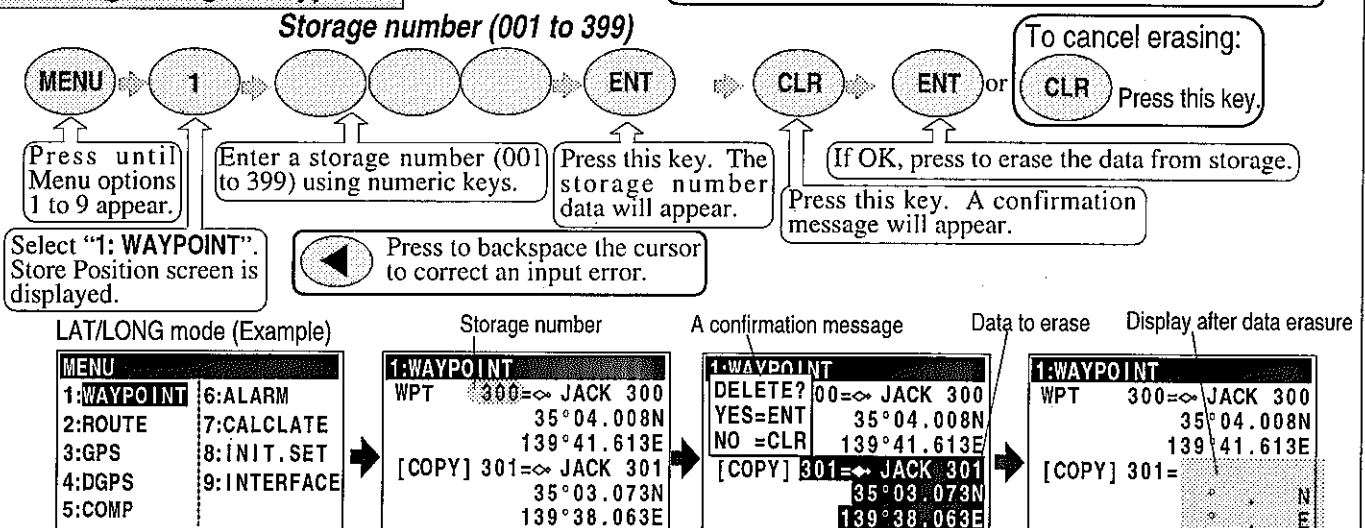

To erase an entire data from memory simultaneously, see "Erasing entire data from memory" (page 63).

Setup of Waypoint navigation

The position data for each waypoint must be set prior to navigating to waypoints. You can use the data already stored from Menu, or you can set the waypoints on A (NAV1), B (NAV2), C (NAV3) or D (PLOT) screen (called the quick waypoint navigation).

Setting waypoint navigation

Use waypoint navigation to go to a single waypoint destination. You can recall the waypoint from the A (NAV1), B (NAV2), C (NAV3) or D (PLOT) screen. Use the following keys to start waypoint navigation:

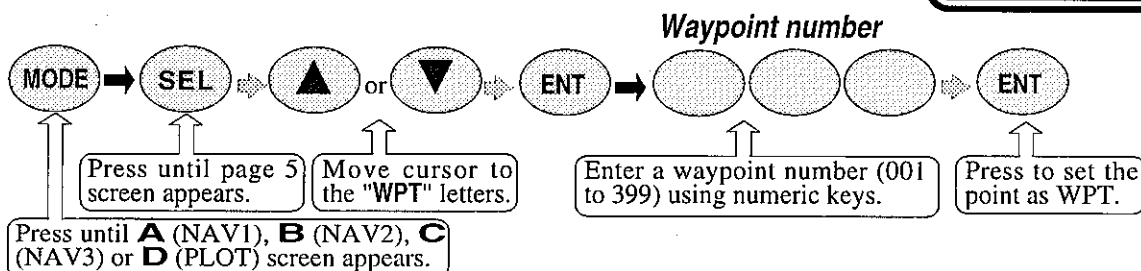
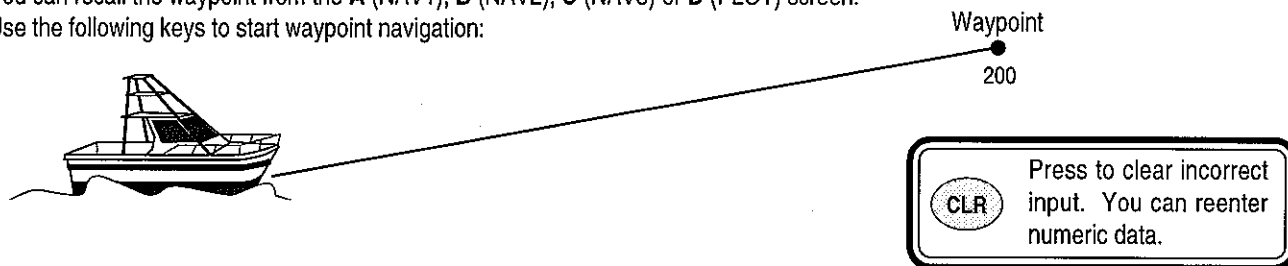

LAT/LONG display (example)

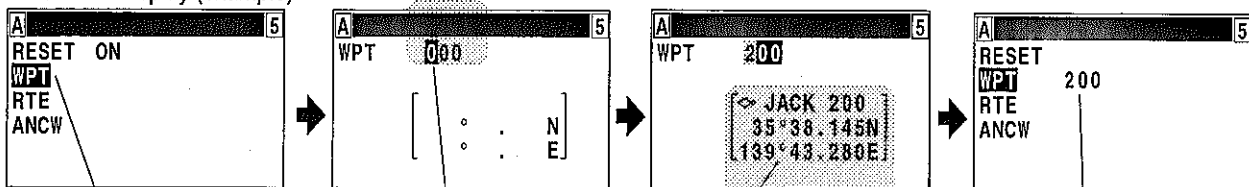

Cursor

Waypoint number

Position data used as the waypoint.

The registration number recalled will be shown as the waypoint number.

Recalling a waypoint

You can recall and recheck the present waypoint from the Menu in waypoint navigation.

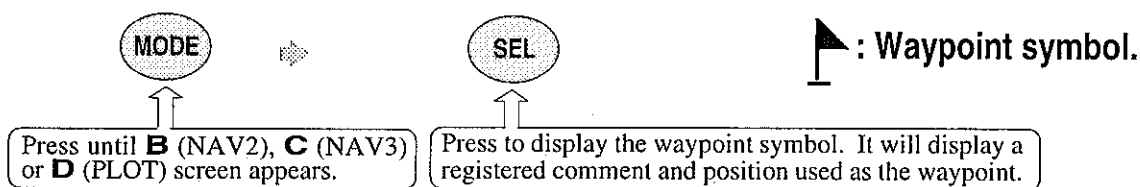

B (NAV2) screen

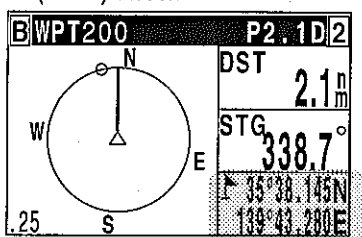

Position data

C (NAV3) screen

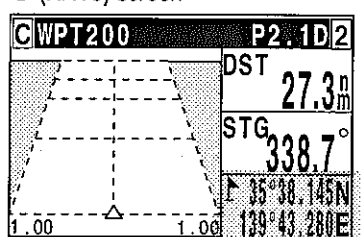

Position data

D (PLOT) screen

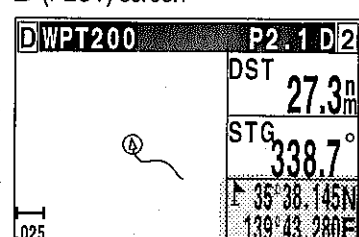

Position data

Waypoint positions will be displayed in the 2nd, 3rd and 4th pages.

Waypoint positions will be displayed in the 2nd, 3rd and 4th pages.

Waypoint position will be displayed in the 2nd page.

Quick WPT setup

Quick WPT (first priority waypoint) can be set by specifying it directly either from the **A** (NAV 1), **B** (NAV 2), **C** (NAV 3) or **D** (PLOT) screen. When the new waypoint is selected, the waypoint navigation to it will commence and the specified position, along with the comment (◇ QUICK), will be assigned to the position number 398. Old data is replaced with a new during quick WPT setup.

While the 1st to 4th pages of either the **A** (NAV 1), **B** (NAV 2), **C** (NAV 3) or **D** (PLOT), are displayed.

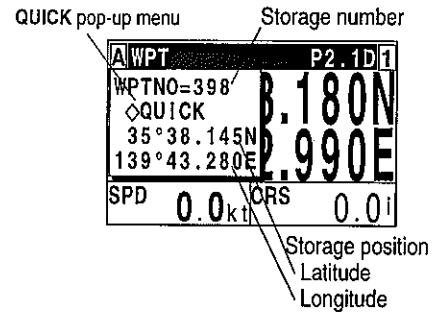
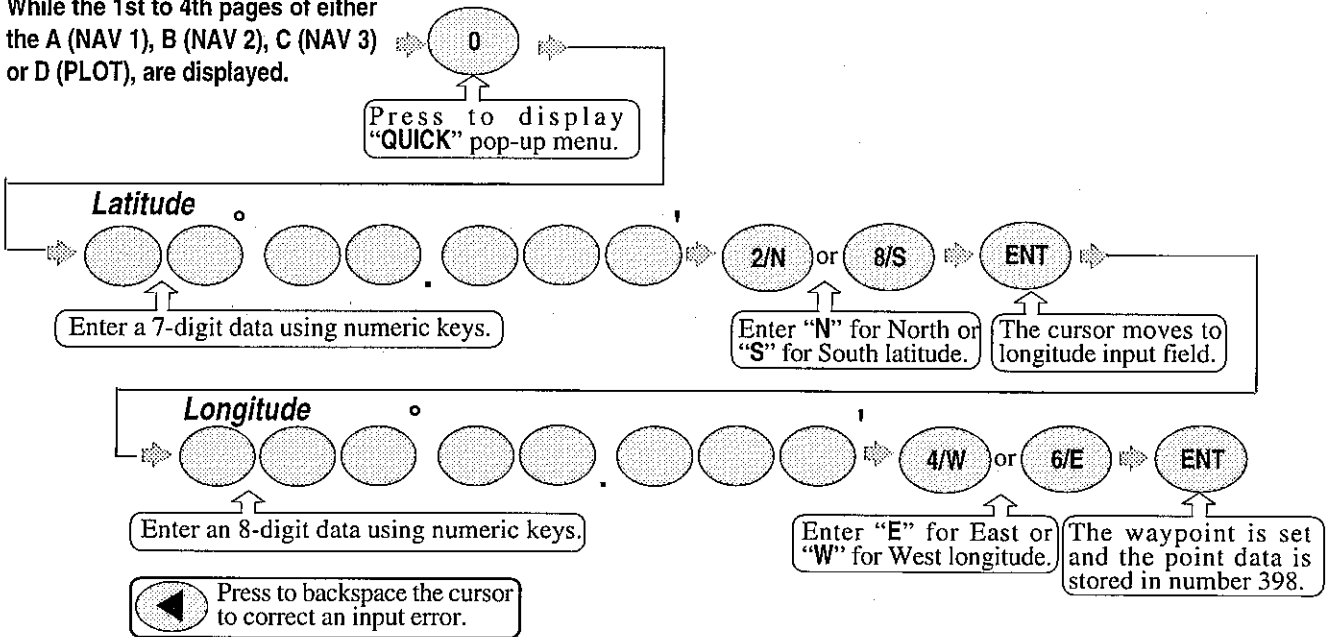

All the entry should be in lat/long except Loran C LOPs.

Reentering the starting point in waypoint navigation

Once reset, the present position is used as the new point of origin for waypoint navigation.

While the 1st to 4th pages of either the **A** (NAV 1), **B** (NAV 2), **C** (NAV 3) or **D** (PLOT), are displayed.

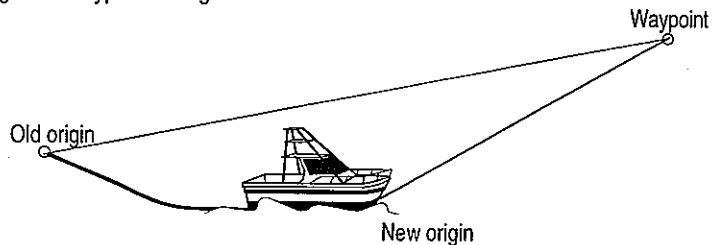
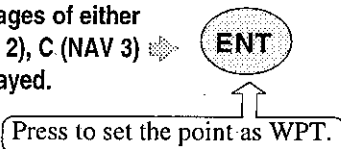

Canceling waypoint navigation

To cancel waypoint navigation, turn WPT to OFF on **A** (NAV1), **B** (NAV2), **C** (NAV3) or **D** (PLOT) screen.

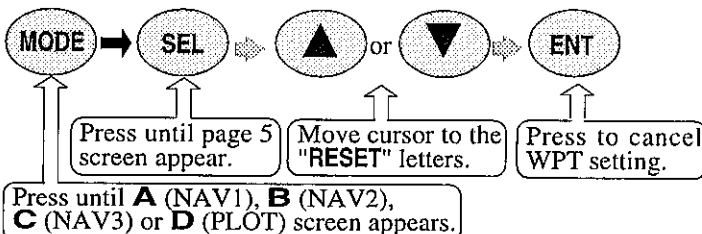

"ON" letters are displayed, and number are cleared.

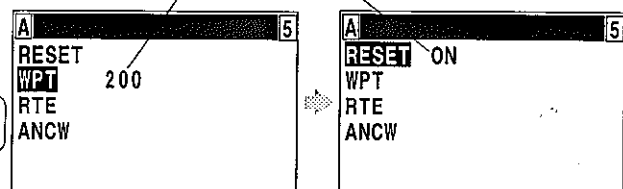

B (NAV2) screen during waypoint navigation

To change a display page: **SEL** Press until the desired page appears.

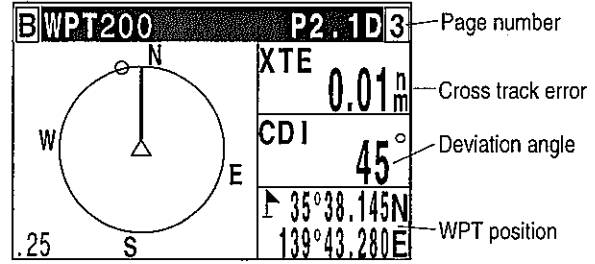
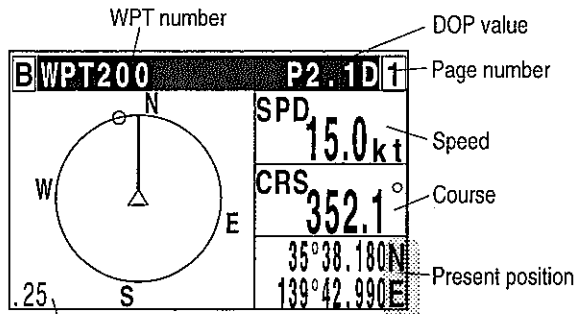

Range (radius) of navigation graph Blinks when position fix is unavailable.

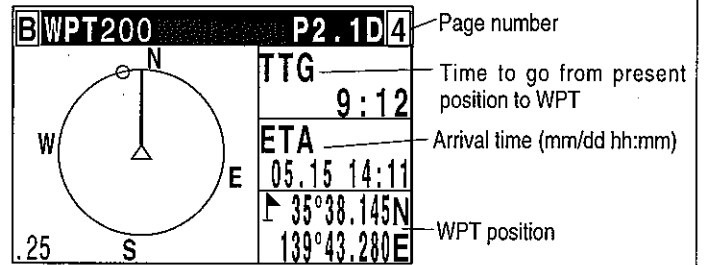
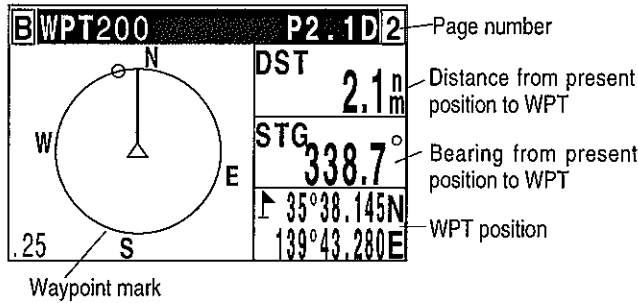

Waypoint mark

C (NAV3) screen during waypoint navigation

To change a display page: **SEL** Press until the desired page appears.

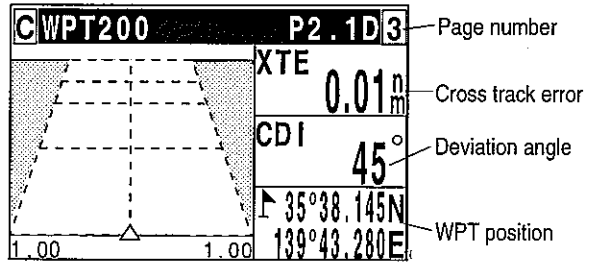
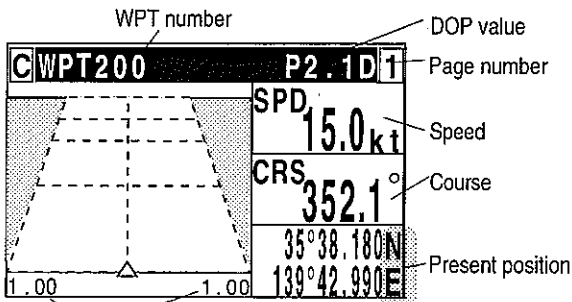

XTE alarm range Blinks when position fix is unavailable.

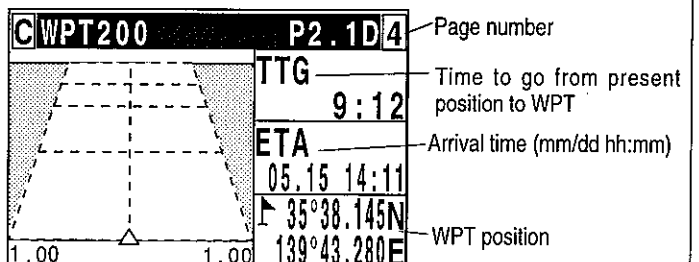
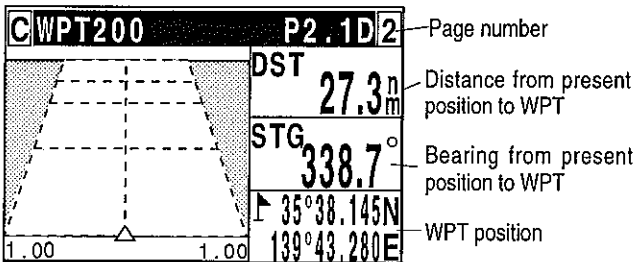

D (PLOT) screen during waypoint navigation

To change a display page: **SEL** Press until the desired page appears.

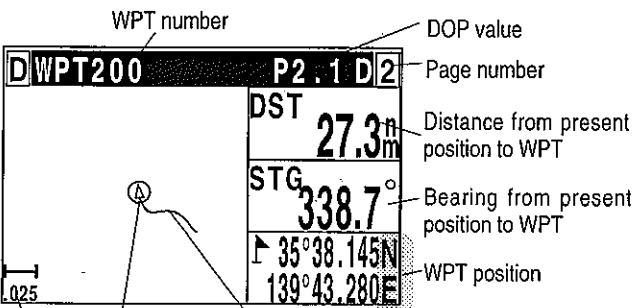

For description of the items shown in the 1st, 3rd and 4th pages of the D (PLOT) screen, refer to "D (PLOT) screen in OFF mode" in page 8. They are used in the same manner.

Scale Your ship's position Track Blinks when position fix is unavailable.

Cross track error and course deviation angle

Navigation graph of B (NAV2) screen

Use the navigation graph to check the distance and bearing to the waypoint. When the distance to WPT is further than the range (radius) of navigation graph, the WPT locates on the circle of navigation graph. When the distance is closer than the graph range, the WPT marking shows in the circle. The XTE bar graph and course deviation angle bar graphs appear only when the WPT is on the circle (these graphs are cleared in the short distance).

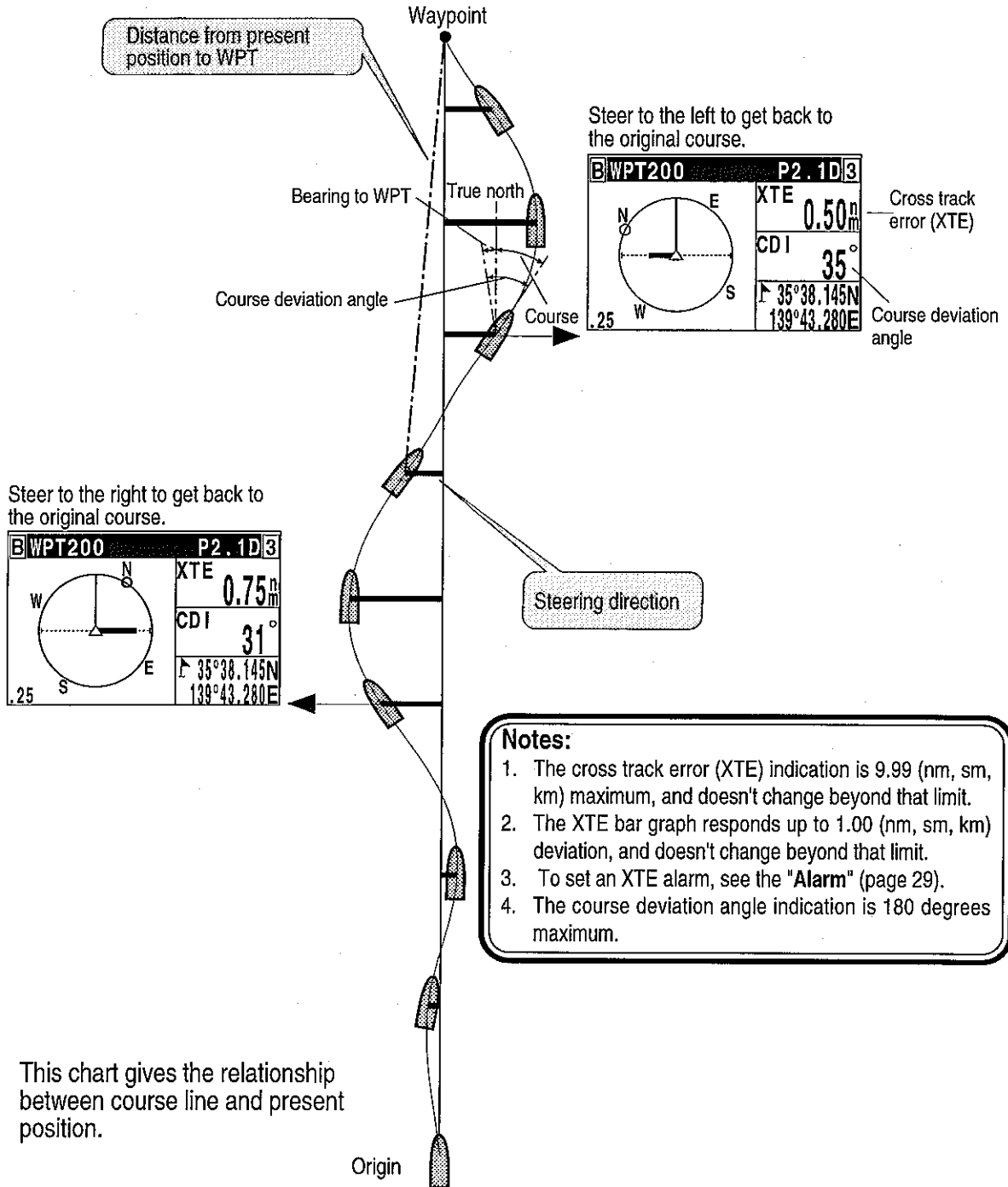

Changing the range (radius) of navigation graph

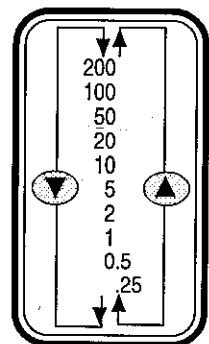
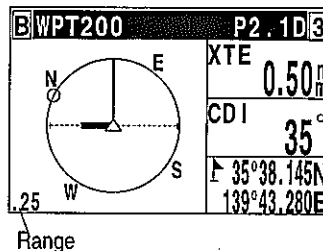
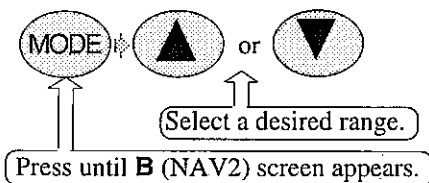

Electronic fairway (NAV3) screen

Use the three-dimensional chart for navigation on the course line. You can set a course width from Menu (6: Alarm). Symbol "▲" shows the waypoint, and your ship and track are shown along the course line.

When waypoint is distant

When the distance is greater than 4 (nm, sm, km), the 4-(nm, sm, km) course line is shown on the screen. When you have sailed 2 (nm, sm, km), the present position indication moves toward you and the next 4 (nm, sm, km) are shown.

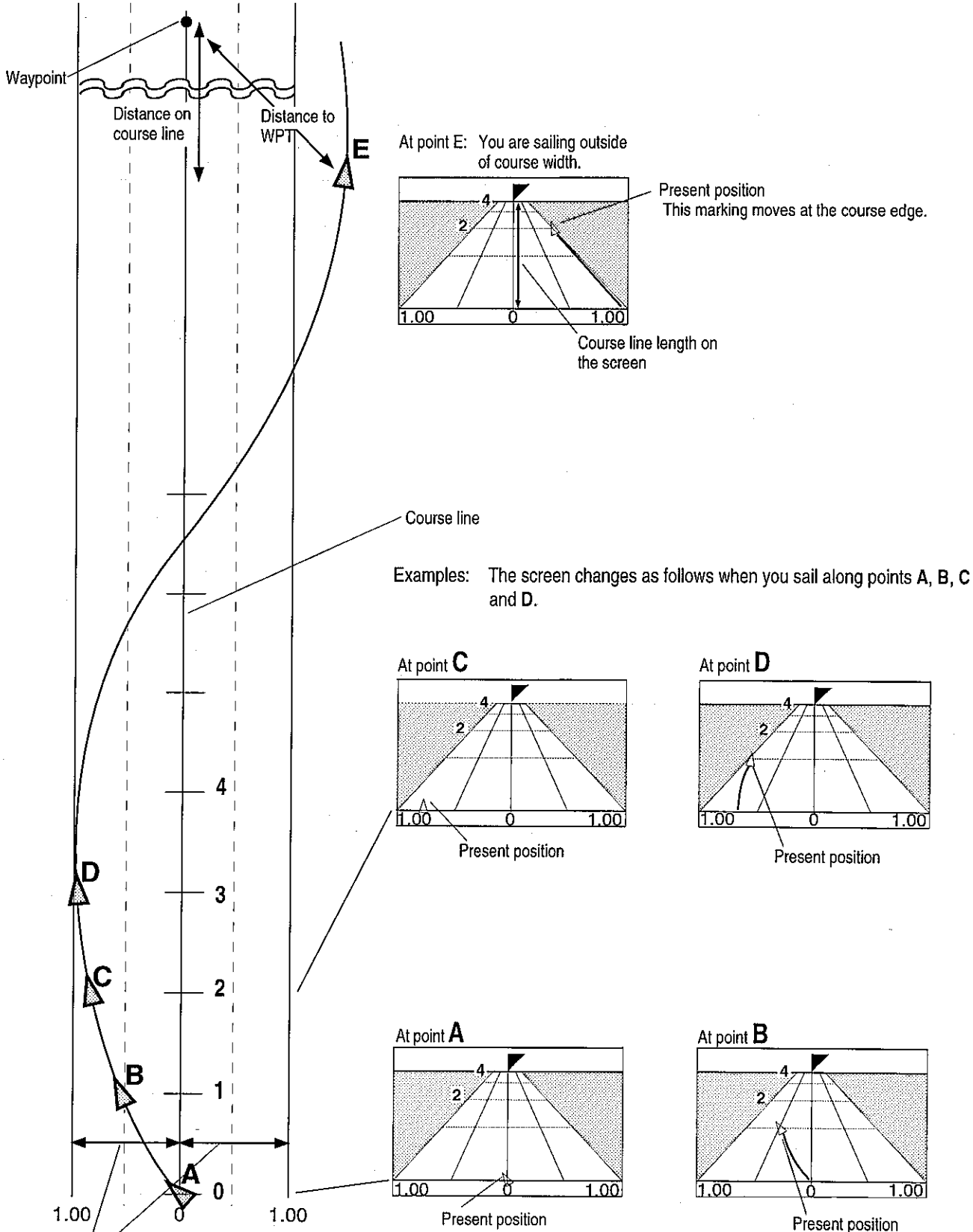

XTE alarm range

You can change the XTE alarm range by "Setting and canceling an XTE alarm" (page 29 to 31).

Nearing to the WPT

When you close to the waypoint, the course line length decreases to 4 (nm, sm, km), 2 (nm, sm, km) and 1 (nm, sm, km). Then, the WPT marking closes to your ship.

WPT marking changes:

- ▶ When distance on course line is greater than 4 (nm, sm, km)
- ▶ When distance on course line is less than 4 (nm, sm, km)

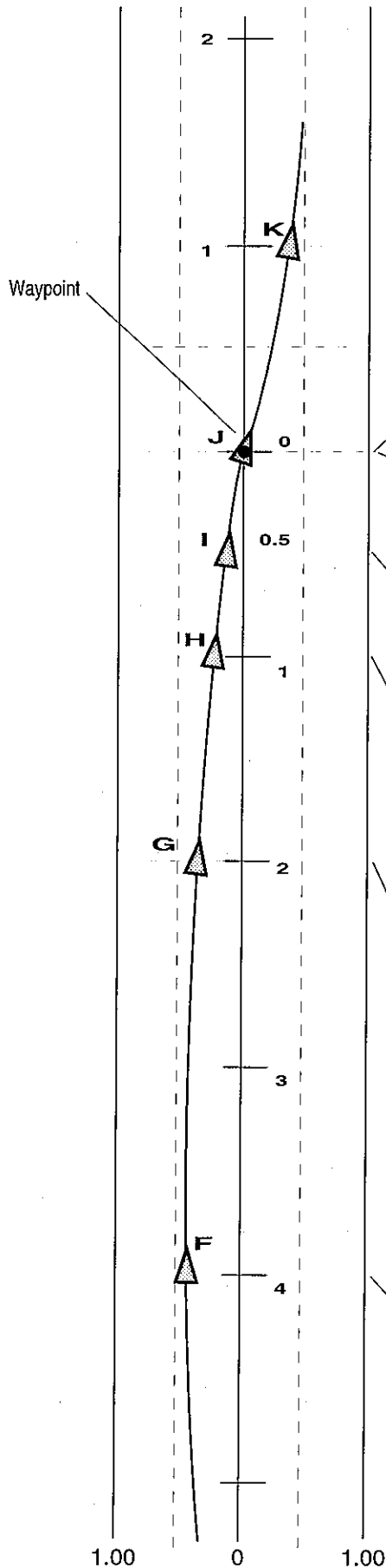

At point K: Distance to WPT is greater than 1 (nm, sm, km).

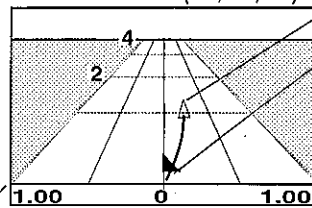

Present position

Waypoint

The WPT indication remains close to you, but the course length increases to 1 (nm, sm, km), 2 (nm, sm, km), and 4 (nm, sm, km). The WPT indication changes when the length exceeds 4 (nm, sm, km).

At point J: You have reached the waypoint.

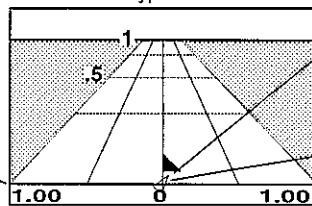

Waypoint

The WPT marking moves toward you.

Present position

At point I: You are 0.5 (nm, sm, km) away from waypoint.

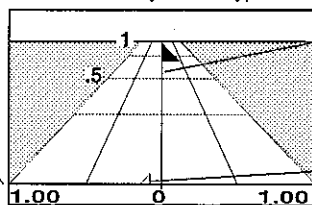

Waypoint

The WPT marking moves to the center of course line.

Present position

At point H: You are 1 (nm, sm, km) away from waypoint.

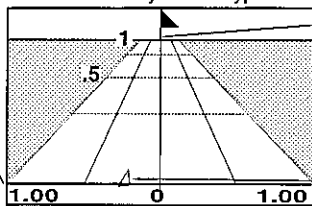

Waypoint

The course length closing up to 1- (nm, sm, km) scale from 2- (nm, sm, km) scale.

Present position

At point G: You are 2 (nm, sm, km) away from waypoint.

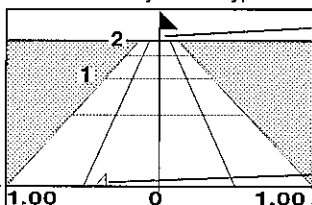

Waypoint

The course length closing up to 2- (nm, sm, km) scale from 4- (nm, sm, km) scale.

Present position

At point F: You are 4 (nm, sm, km) away from waypoint.

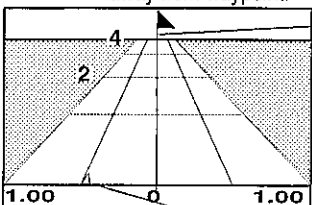

Waypoint

The present position indication moves toward you and the WPT indication changes when you have reached 4 (nm, sm, km) on the course line away from the waypoint.

Present position

Storing and Erasing Routes

Storing your route

- Route can be registered up to 20 routes (01 to 20)
- Number of waypoint can be registered in total 230 points for one route. However, also note that maximum 230 waypoints can be assigned for 20 routes in total.

NOTE: In case you have registered 230 waypoints for one route only, you cannot register any waypoint to other routes. To store the route, you first need to register the waypoint on route in the menu, "1. WAYPOINT".

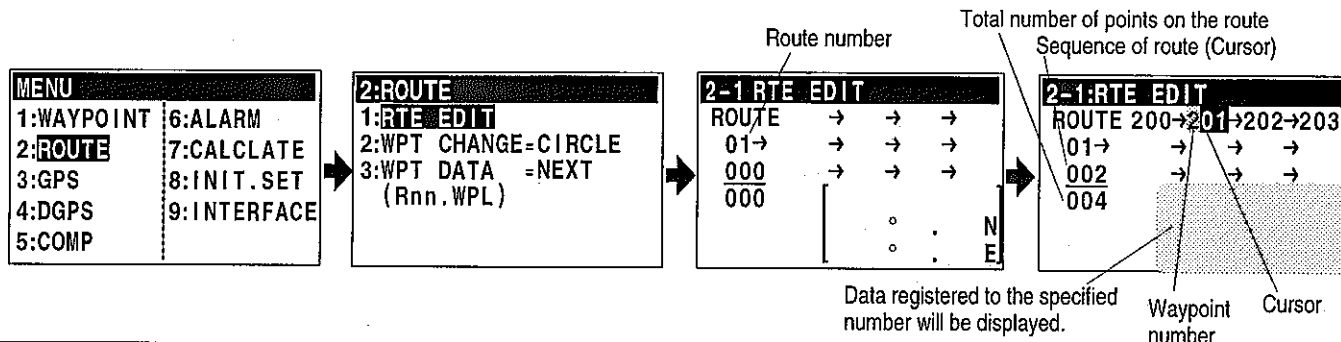
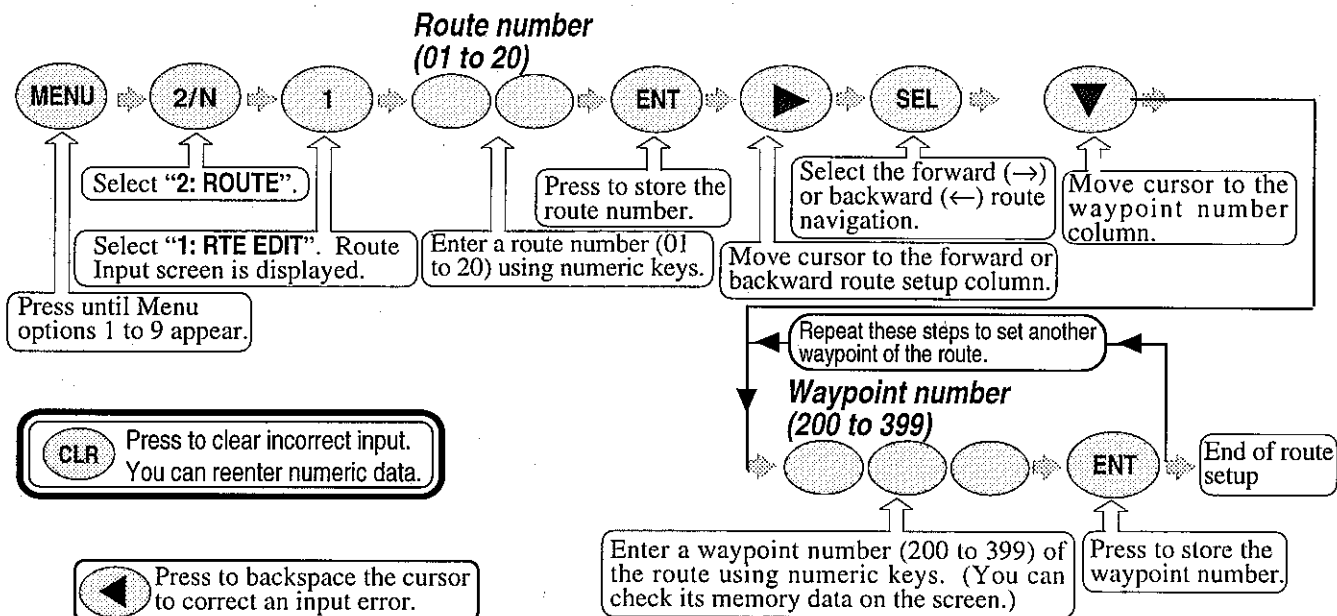

Automatic switching of waypoints

Route navigation can switch the current waypoint in two ways: switching in CIRCLE mode and switching in BI-SECTOR mode. In CIRCLE mode, the next waypoint is shown when you reach the proximity alarm circle. In BI-SECTOR mode, the next waypoint is shown when you cross a half-angle line.

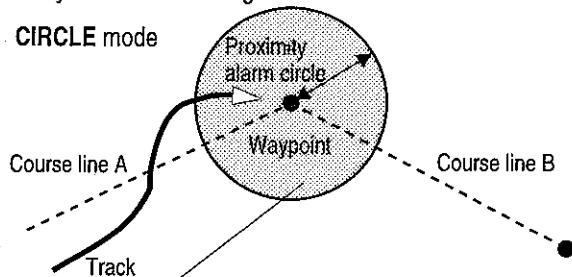

When you reach the proximity alarm circle, the course line is switched from A to B. To change the proximity alarm range, see "Setting and canceling a proximity alarm" (page 37).

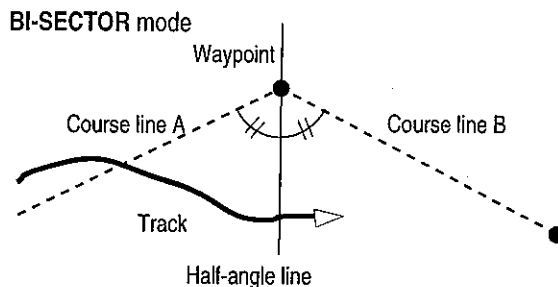

When you cross a half-angle line, the course line is switched from A to B.

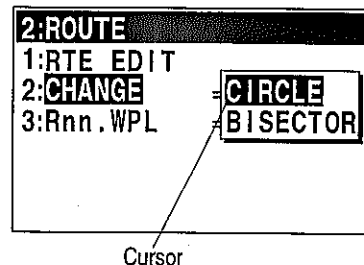
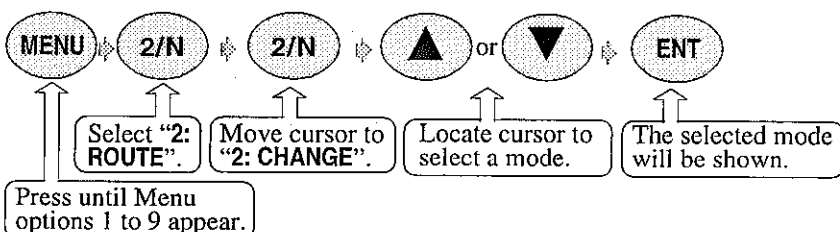

Erasing point data

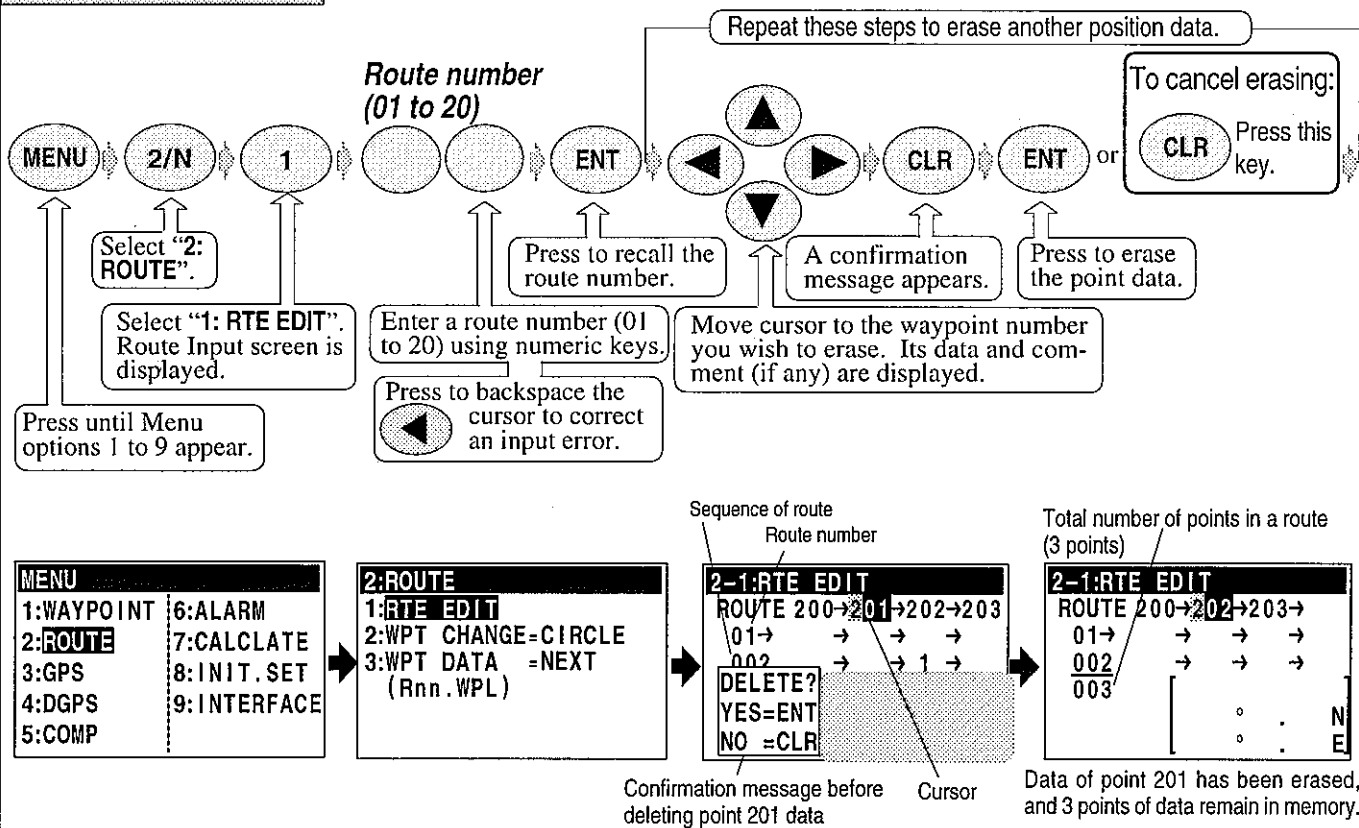

Erasing a single route

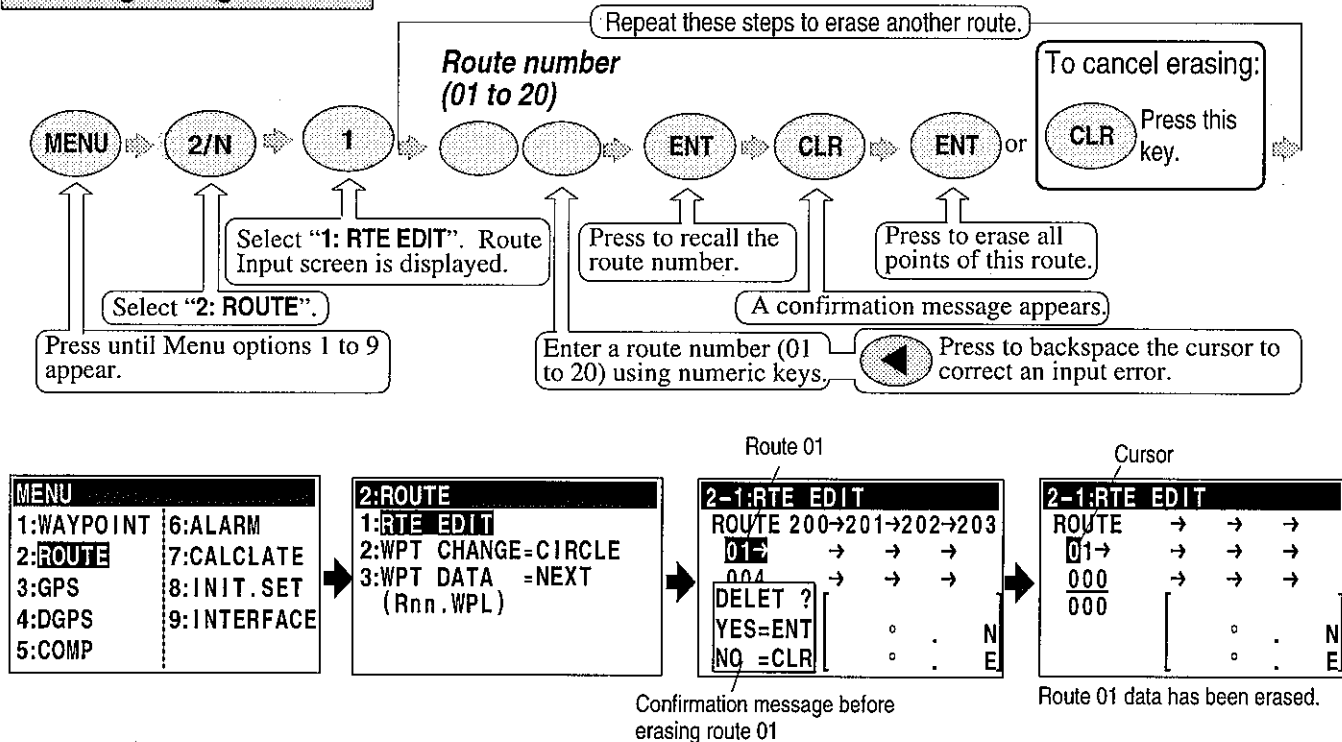

To erase all stored data from memory, see "Erasing entire data from memory" (page 63).

Route Setup

You can use up to 400 points (maximum) to go to a final destination using route navigation. You can also reverse the navigation route to return to the start point. To do so, you must first store the waypoints and route from Menu (using option 2). See "Storing waypoints (LAT/LONG)" (page 13 to 14) and "Storing and Erasing Routes" (page 21 and 22).

You can set the route by entering a route number, forward/backward navigation, and route start point number of the route from the **A** (NAV1), **B** (NAV2), **C** (NAV3) or **D** (PLOT) screen.

Selecting route navigation

You navigate on a route, following the course line, which is automatically updated as you reach each waypoint. Use the following steps to start route navigation.

Select the reverse navigation only after you have reached the final destination, or the route navigation may not work properly.

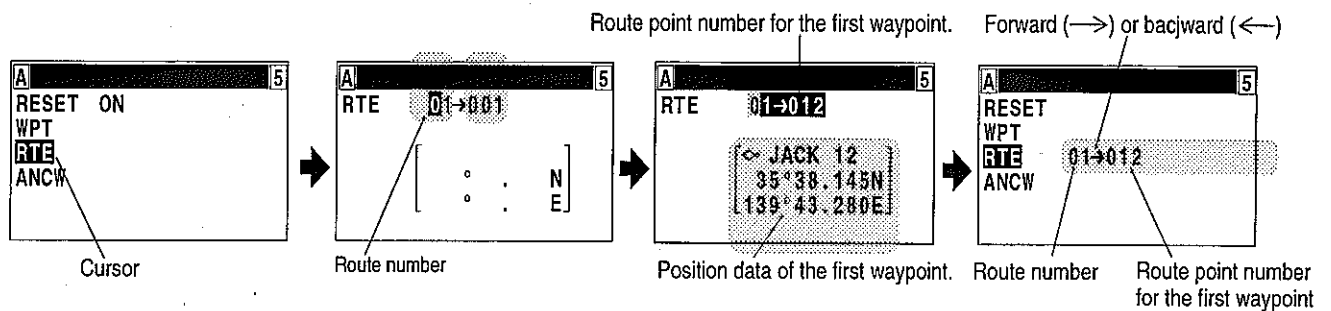
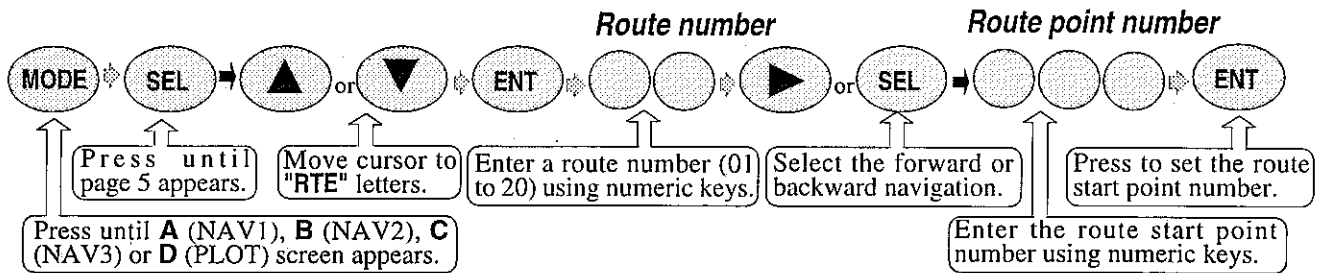
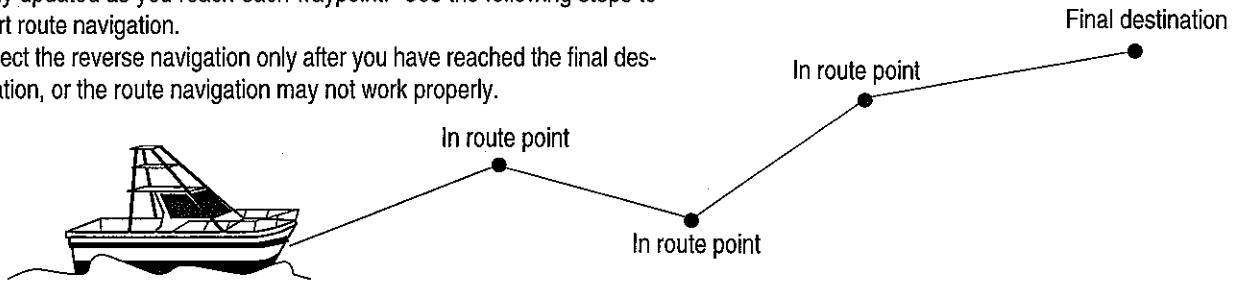

Reentering the origin of route navigation

You can reset the present position as a new point of origin and start navigation.

While the 1st to 4th pages of either the **A** (NAV 1), **B** (NAV 2), **C** (NAV 3) or **D** (PLOT), are displayed.

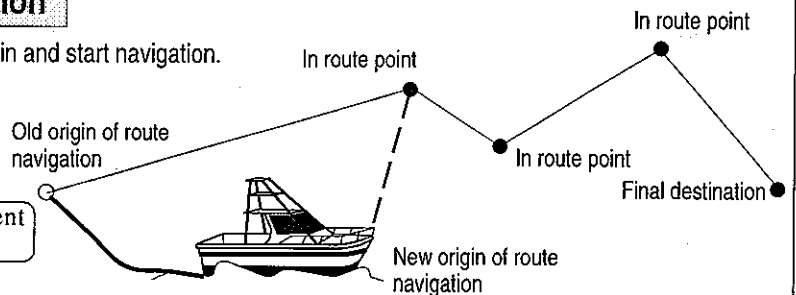
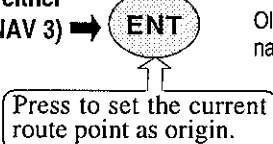

Checking a route point position

You can check the waypoints on a route from the Menu.

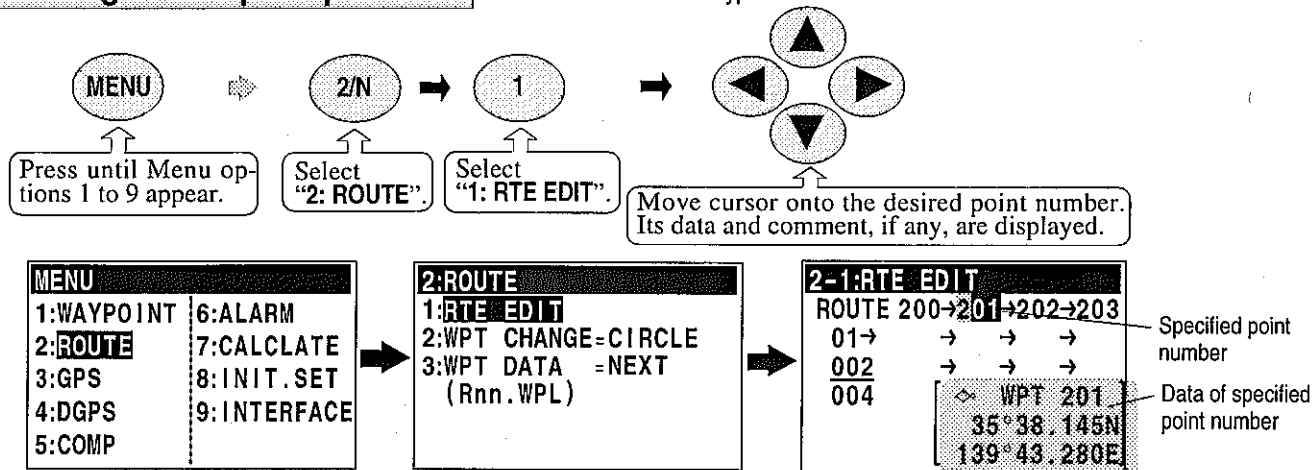

What is the route point number?

Example: To go to waypoint number 201 first, enter route point number "002".

The route points are stored in the following order: 001 → 002 → 003 → 004

Point number specified by cursor

Total number of points on the route

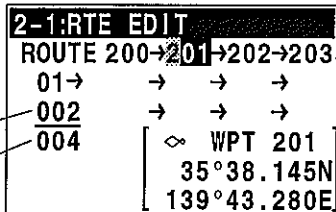

Route point numbers during forward and backward navigation

When you select a route point number 002, the forward (→) and backward (←) navigation are as follows:

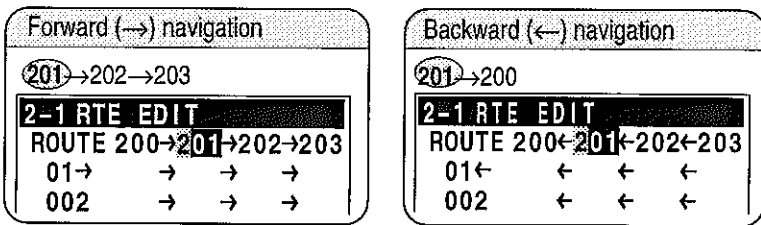

Skipping a route point in route navigation

You can skip the next route point and go to a new route point.

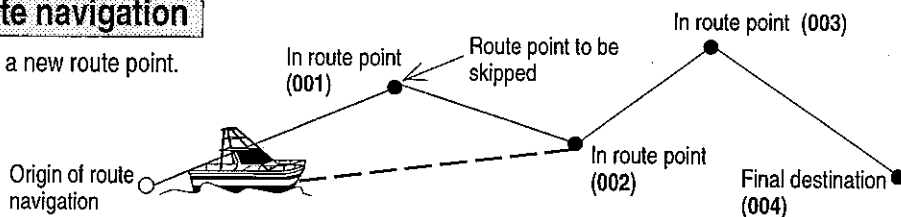

Present position where you have decided to skip the next route point

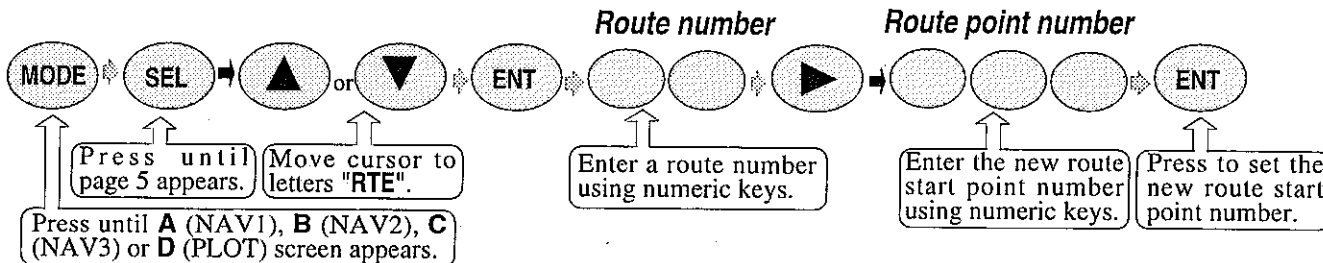

Canceling route navigation

To cancel waypoint navigation, turn RTE to OFF on A (NAV1), B (NAV2), C (NAV3) or D (PLOT) screen.

"ON" letters are displayed, and numbers are cleared.

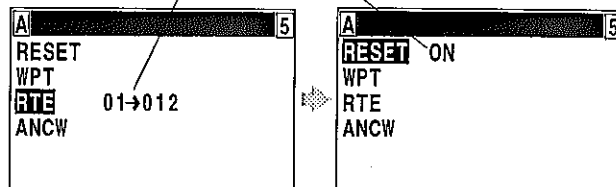
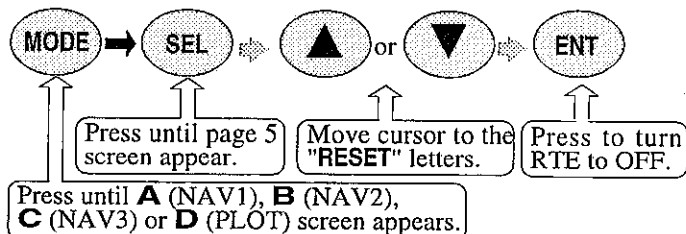

Switching between distance and time to go

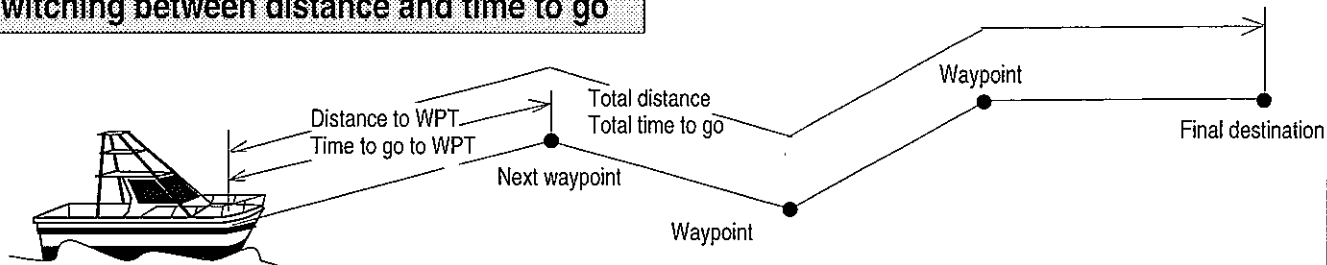

When you select the **"DIST"** (Distance to WPT) or **"TDIST"** (Total distance) on NAV1, NAV2 or NAV3 screen in route navigation, the respective **"TTG"** (Time to go to WPT) or **"T.TTG"** (Total time to go) is shown.

"DIST" shows the distance to the next waypoint.
"T.DIST" shows the total distance to the final destination.

"DST" or "T.DST" display

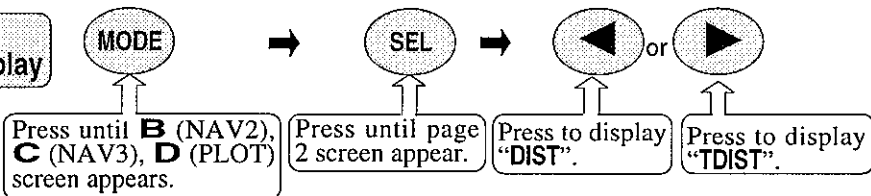

| | | | | | |
|---|--|---|--|---|--|
| BRTE01→001 P2.1D2 DST 27.3n STG 338.7° ↑ 35°38.145N 139°43.280E | | CRTE01→001 P2.1D2 DST 27.3n STG 338.7° ↑ 35°38.145N 139°43.280E | | DRTE01→001 P2.1D2 DST 27.3n CRS 338.7° ↑ 35°38.145N 139°43.280E | |
| BRTE01→001 P2.1D2 TDST 6273n STG 338.7° ↑ 35°38.145N 139°43.280E | | CRTE01→001 P2.1D2 TDST 6273n STG 338.7° ↑ 35°38.145N 139°43.280E | | DRTE01→001 P2.1D2 TDST 6273n CRS 338.7° ↑ 35°38.145N 139°43.280E | |

Page 2.

Distance to WPT

Course to WPT

WPT position

Total distance to WPT

"TTG" or "T.TTG" display

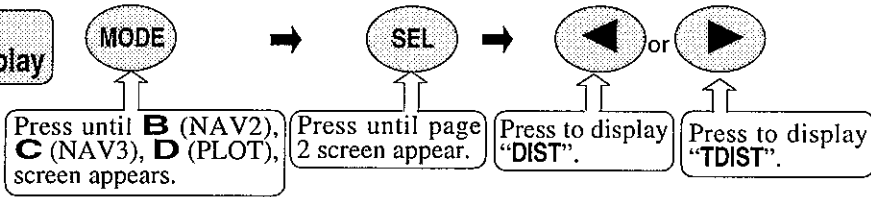

"TTG" shows the time to go to next waypoint.
"T.TTG" shows the total time to go to the final destination (999 hours 59 minutes maximum).

| | | | | | |
|--|--|--|--|--|--|
| BRTE01→001 P2.1D4 TTG 9:12 ETA 05.15 14:11 ↑ 35°38.145N 139°43.280E | | CRTE01→001 P2.1D4 TTG 9:12 ETA 05.15 14:11 ↑ 35°38.145N 139°43.280E | | DRTE01→001 P2.1D4 TTG 9:12 ETA 05.15 14:11 ↑ 35°38.145N 139°43.280E | |
| BRTE01→001 P2.1D4 T.TTG 418:12 ETA 05.15 14:11 ↑ 35°38.145N 139°43.280E | | CRTE01→001 P2.1D4 T.TTG 418:12 ETA 05.15 14:11 ↑ 35°38.145N 139°43.280E | | DRTE01→001 P2.1D4 T.TTG 418:12 ETA 05.15 14:11 ↑ 35°38.145N 139°43.280E | |

Page 4.

Time to go to WPT

Final arrival time

WPT position

Total time to go

B (NAV2) screen during route navigation

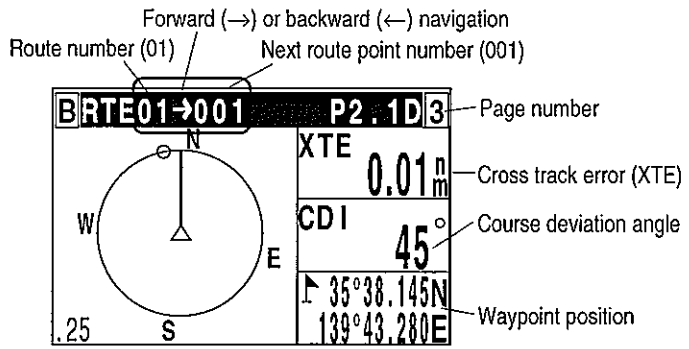
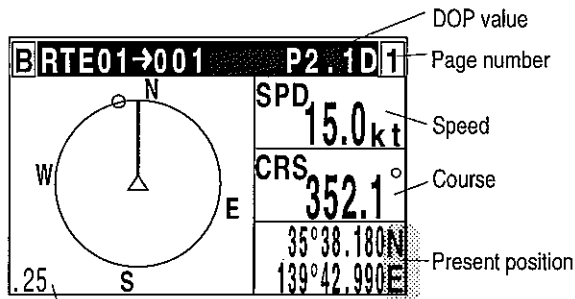

Range (radius) of navigation graph Blinks when your position has failed to fix.

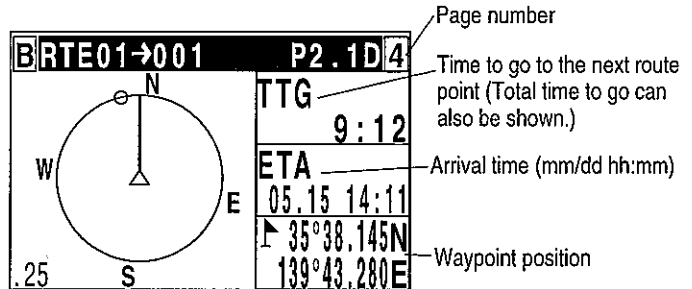
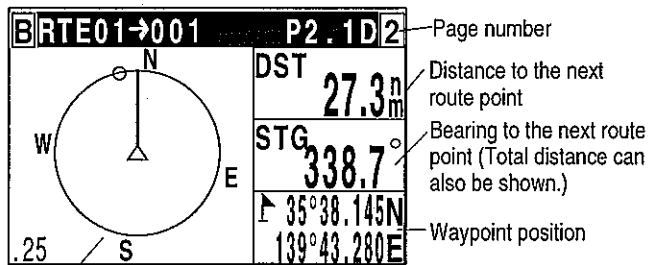

Waypoint mark

DST : 9999 Positioning has failed or the distance has exceeded 9999 nm, sm or km.

To change a display page: **SEL** Press until the desired page appears.

C (NAV3) screen during route navigation

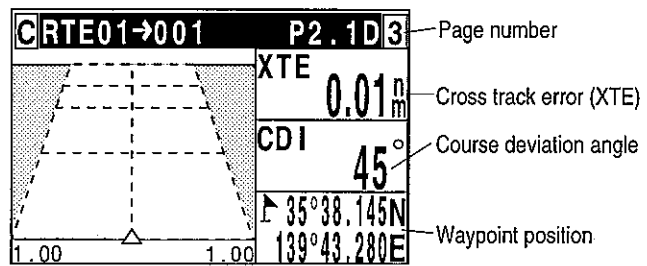
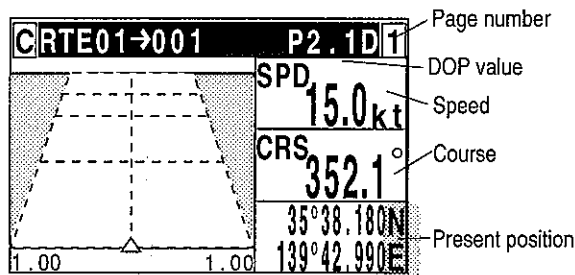

Blinks when your position has failed to fix.

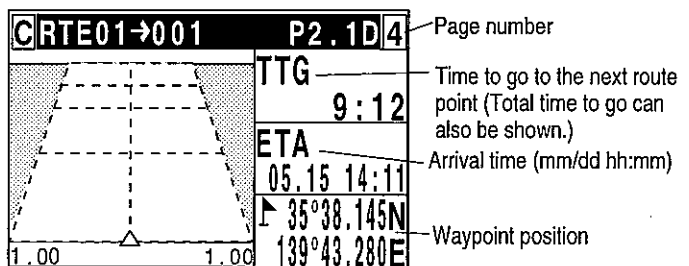
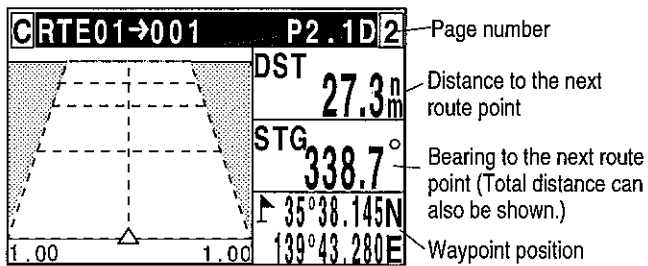

Positioning has failed or the time to go has exceeded 999 hours 59 minutes.

TTG : 999:99

ETA : 12.31 23:59

To change a display page: **SEL** Press until the desired page appears.

D (PLOT) screen during route navigation

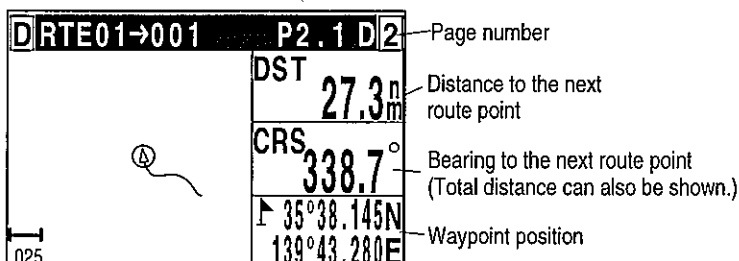

To change a display page: **SEL** Press until the desired page appears.

For description of the parameters shown in the 1st, 3rd and 4th pages of the D (PLOT) screen, refer to "D (PLOT) screen in OFF mode" in page 8. They are used in the same manner.

Setting an anchor position

After arriving at your destination, it is possible to drift from the anchor position due to a tide or wind. Once the anchor position is stored in memory, it is easy to check the distance and bearing moved from the anchor position.

Storing an anchor position

You can set the anchor position from the **A** (NAV1), **B** (NAV2), **C** (NAV3) or **D** (PLOT) screen.

The following operations allow you to store and specify the current position as the anchor position. The anchor position is registered to memory number 397 along with the comment (⚓ ANCW).

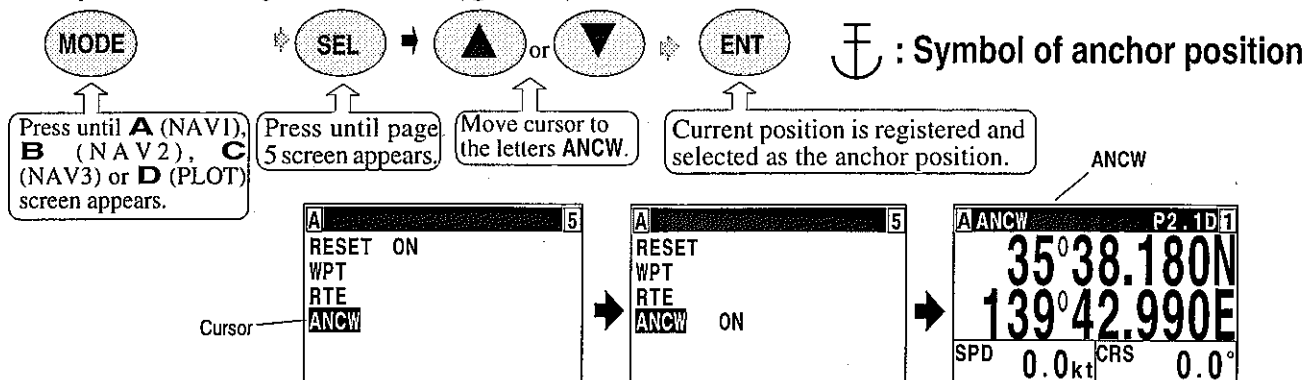

Recalling the anchor position

You can check the anchor position on any of **A** (NAV1), **B** (NAV2), **C** (NAV3) and **D** (PLOT) screens during anchoring.

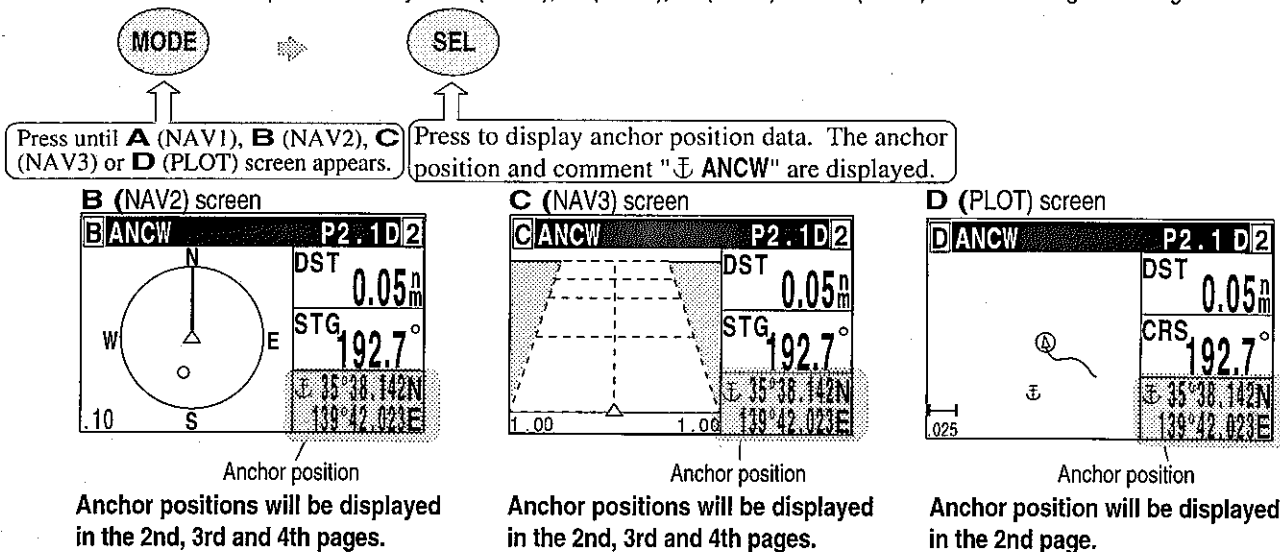

Removing the anchor position symbol on PLOT screen

You can remove the anchor position as a symbol on the PLOT screen.

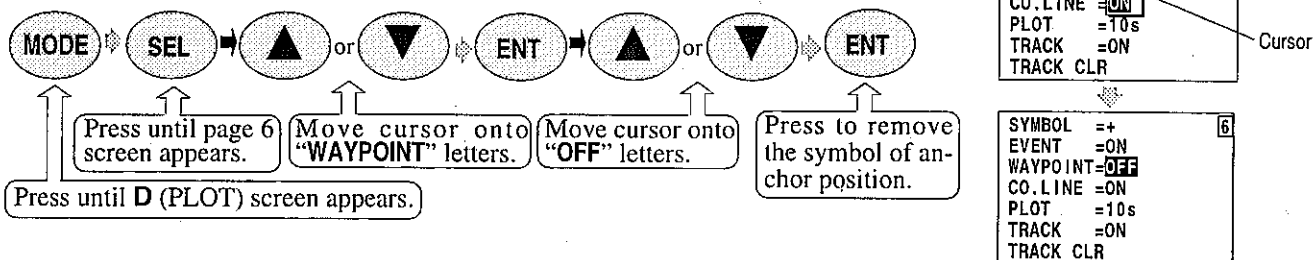

Reentering an anchor position

You can reenter a new anchor position and start to calculate navigation.

While the 1st to 4th pages of either the **A** (NAV 1), **B** (NAV 2), **C** (NAV 3) or **D** (PLOT), are displayed.

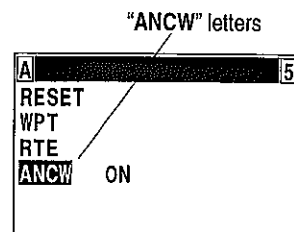
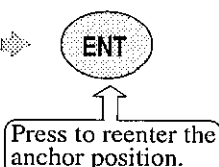

Canceling the anchor position

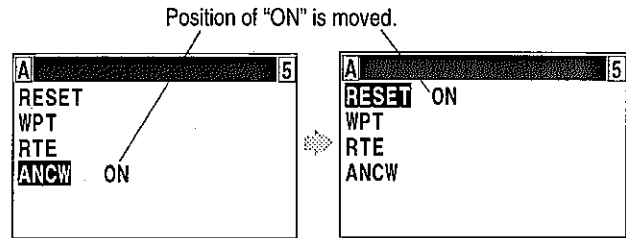
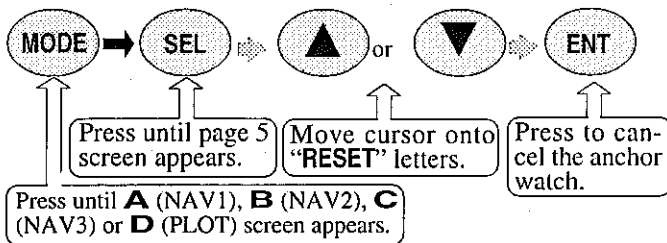

B (NAV2) screen during anchor position setup

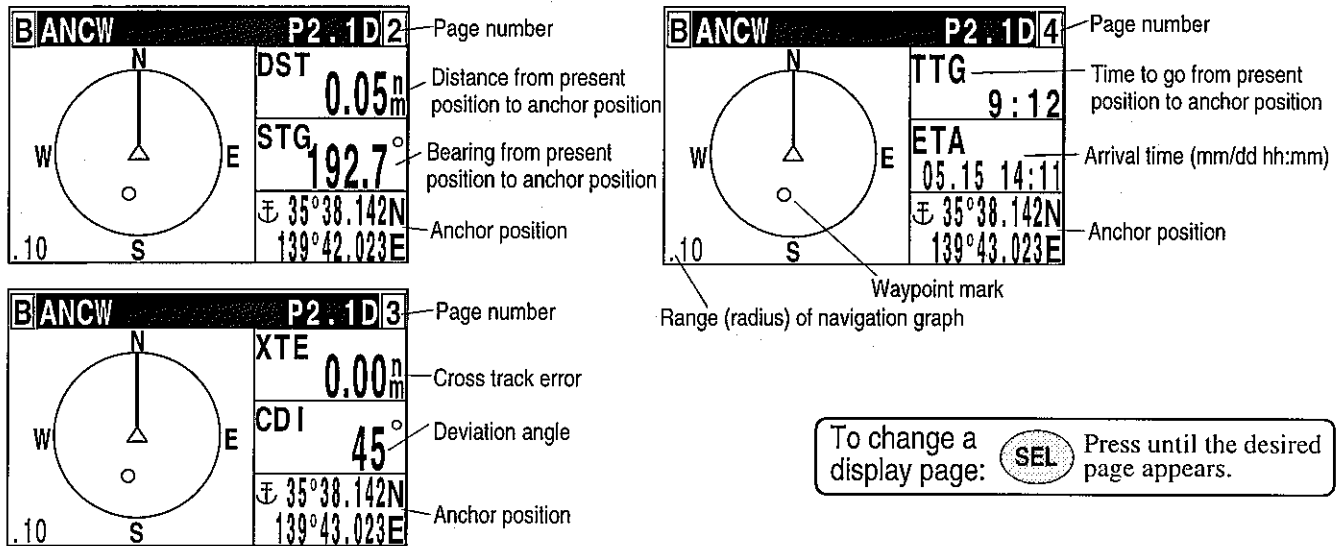

C (NAV3) screen during anchor position setup

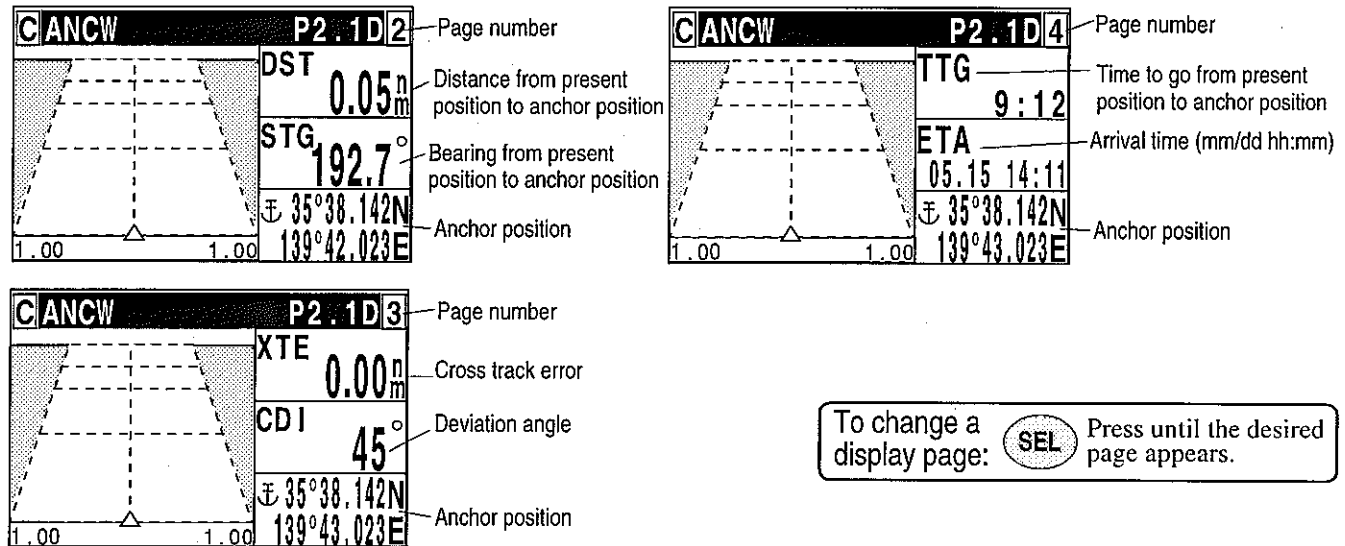

The 3D PLOT screen shows the distance, bearing, cross track error (XTE), and course deviation angle to the waypoint. Your boat icon does not move in the ANCW mode.

D (PLOT) screen during anchor position setup

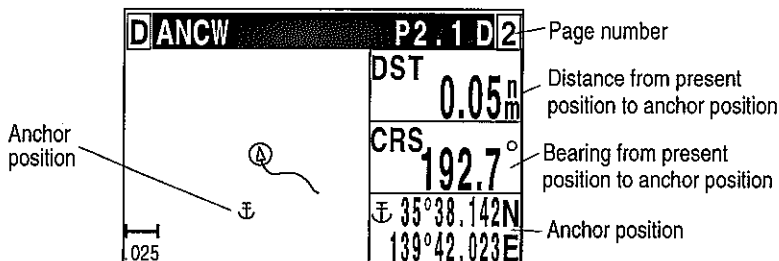

For description of the parameters shown in the 1st, 3rd and 4th pages of the D (PLOT) screen, refer to "D (PLOT) screen in OFF mode" in page 8. They are used in the same manner.

To change a display page: **SEL** Press until the desired page appears.

Alarms

Kinds of alarm

What is a GPS fix alarm?

Initial setup: OFF

GPS fix alarm warns you of poor GPS positioning data by blinking N/S and E/W (or S1 and S2 in the LOP display).

What is a DGPS fix alarm?

Initial setup: OFF

DGPS fix alarm warns you of poor DGPS positioning data by blinking the letter D.

What is an anchor watch alarm?

Initial setup: OFF, 1.00
Enter an alarm range: 0.00 to 9.99

An anchor watch alarm can alert you if your boat drifts a set distance from where it is activated. This alarm function will not work if the alarm range is set to "0.00".

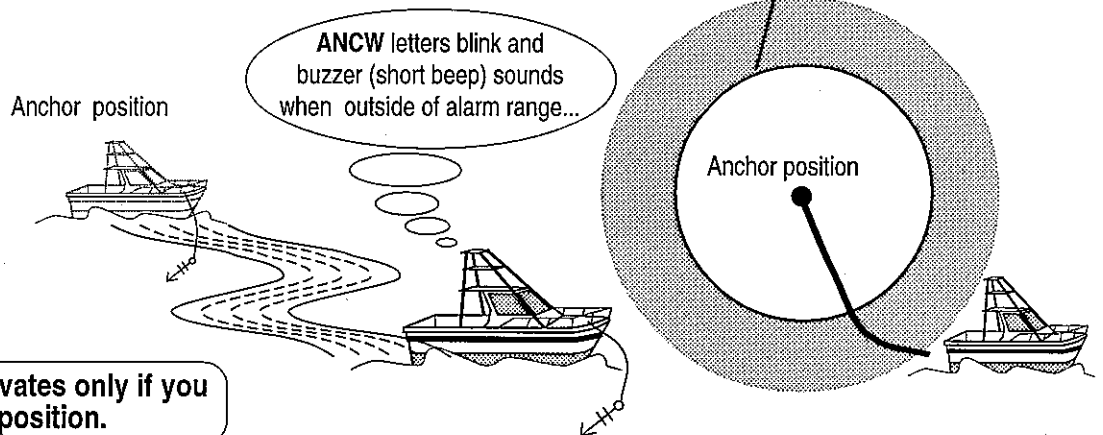

The alarm activates only if you set an anchor position.

What is a proximity alarm?

Initial setup: ON, 1.00
Enter an alarm range: 0.00 to 9.99

A proximity alarm alerts you when you arrive to within a preset distance to a waypoint. The proximity alarm will not work if the alarm range is set to "0.00". Note: you will automatically advance to the next waypoint at the alarm range if you have selected the CIRCLE mode of route navigation by "Automatic switching of waypoints" (page 25).

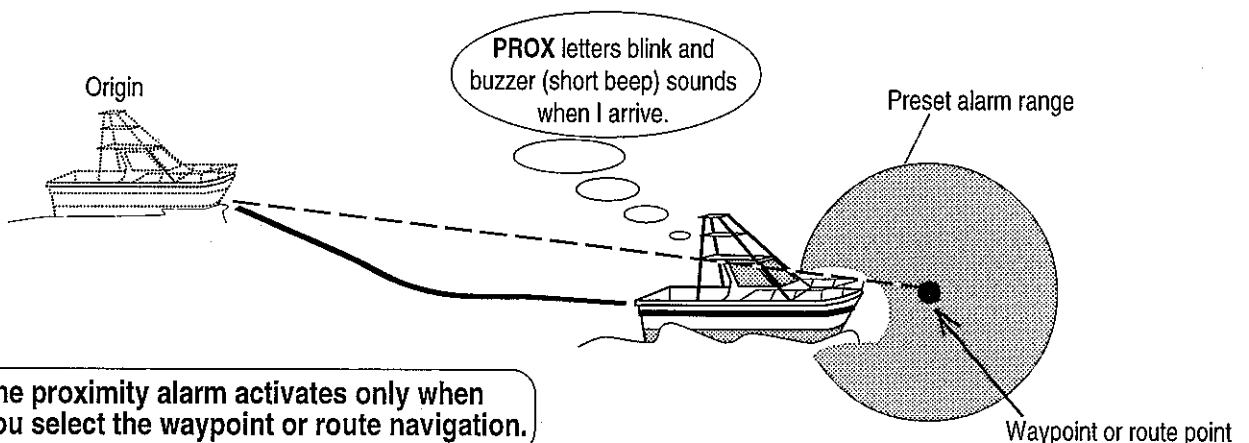

The proximity alarm activates only when you select the waypoint or route navigation.

What is an XTE (course deviation)?

Initial setup: ON, 1.00

Enter an alarm range: 0.00 to 9.99

The cross track error (XTE) alarm alerts you when you have deviated from your course line by a predetermined distance.

The alarm function does not work if the alarm range is set to '0.00'. The course width shown on NAV3 screen is the same as the XTE alarm value you have set.

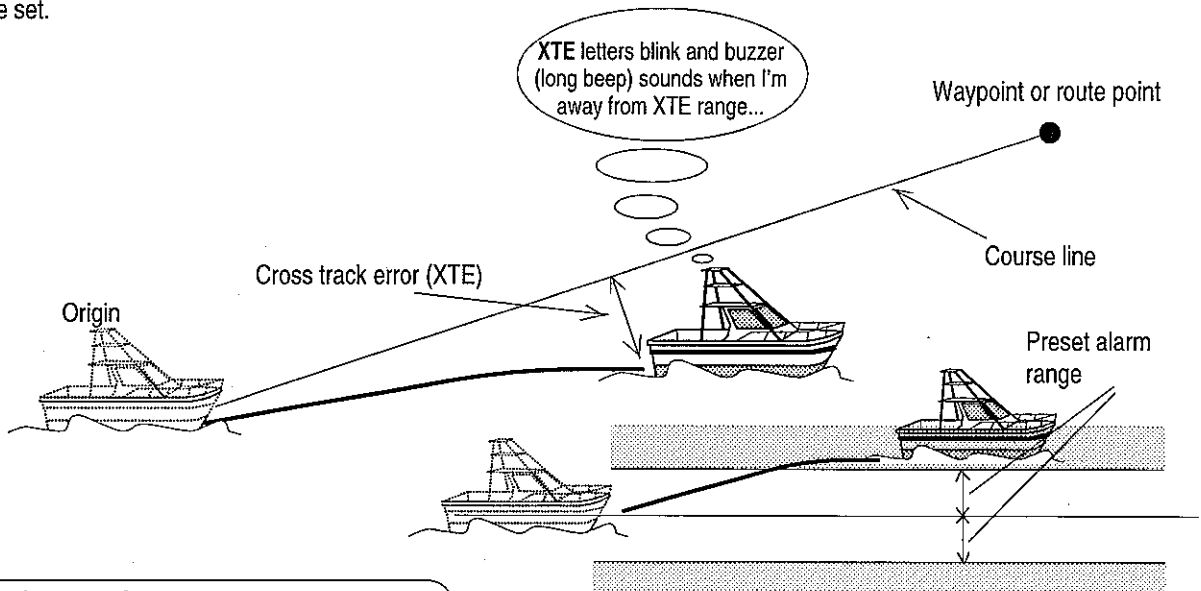

The XTE alarm activates only when you select the waypoint or route navigation.

What is a CDI (course deviation angle)?

Initial setup: ON, 45 degrees

Enter an alarm range: 00 to 99 degrees

The CDI alarm alerts you when you deviate from your course to steer by a predetermined margin.

The alarm function does not work if the alarm range is set to 100°.

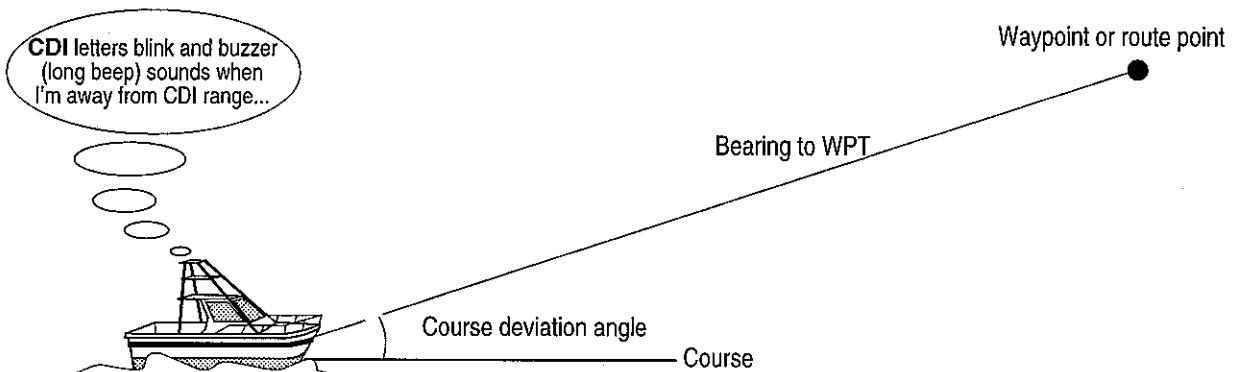

The CDI alarm activates only when you select the waypoint or route navigation.

Alarm explanation

Reason for alarm notification is displayed similar to example shown.

```
6-6:ALARM
GPS NO FIX
DGPS NO FIX
PROXIMITY ALM ERR
ANCHOR WATCH ALM ERR
CROSS TRACK ERR(XTE)
COURSE DEVIATION ERR
```

Setting and canceling

How to use menus

Setting alarm

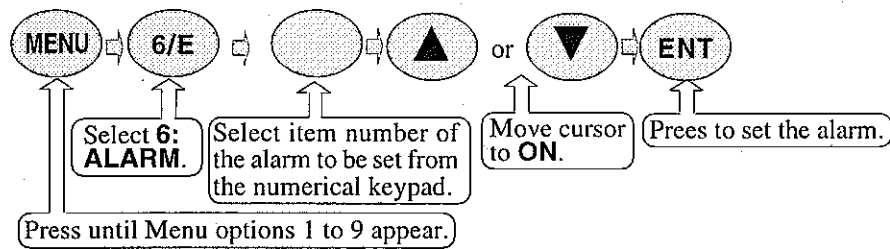

Changing alarm range

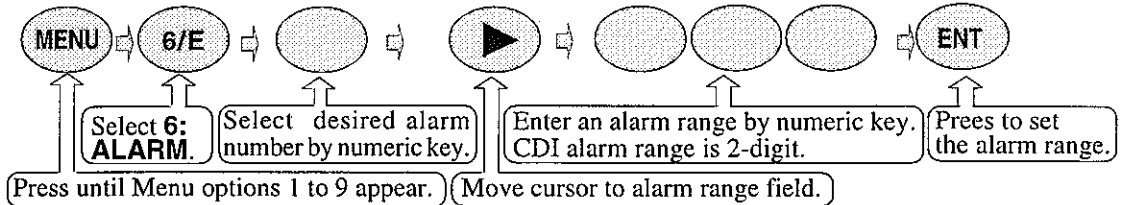

Canceling alarm

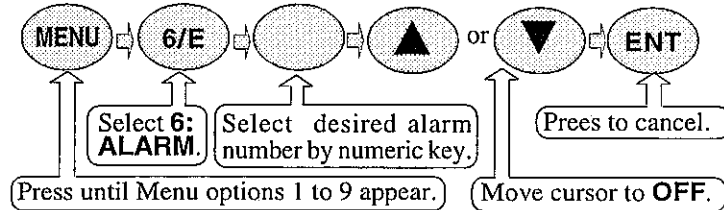

Returning to display mode.

Press the **MODE** key.

Example

| | |
|-------------|----------------|
| MENU | 6:ALARM |
| 1:WAYPOINT | 7:CALCLATE |
| 2:ROUTE | 8:INIT.SET |
| 3:GPS | 9:INTERFACE |
| 4:DGPS | |
| 5:COMP | |

| | |
|----------------|-------------|
| 6:ALARM | |
| 1:FIX | =OFF |
| 2:ANCW | =OFF 1.00nm |
| 3:PROX | =OFF 1.00nm |
| 4:XTE | =ON 1.00nm |
| 5:CDI | =ON 45° |
| 6:MESSAGE | |

Cursor

Setting PROX alarm

| | |
|----------------|-------------|
| 6:ALARM | |
| 1:FIX | =OFF |
| 2:ANCW | =OFF 1.00nm |
| 3:PROX | =OFF 1.00nm |
| 4:XTE | =ON 1.00nm |
| 5:CDI | =ON 45° |
| 6:MESSAGE | |

Select "ON"

| | |
|----------------|------------|
| 6:ALARM | |
| 1:FIX | =OFF |
| 2:ANCW | =ON 1.00nm |
| 3:PROX | =ON 1.00nm |
| 4:XTE | =ON 1.00nm |
| 5:CDI | =ON 45° |
| 6:MESSAGE | |

Setting PROX alarm range

| | |
|----------------|-------------|
| 6:ALARM | |
| 1:FIX | =OFF |
| 2:ANCW | =OFF 1.00nm |
| 3:PROX | =OFF 1.00nm |
| 4:XTE | =ON 1.00nm |
| 5:CDI | =ON 45° |
| 6:MESSAGE | |

Select "ON"

| | |
|----------------|------------|
| 6:ALARM | |
| 1:FIX | =OFF |
| 2:ANCW | =ON 1.00nm |
| 3:PROX | =ON 1.00nm |
| 4:XTE | =ON 1.00nm |
| 5:CDI | =ON 45° |
| 6:MESSAGE | |

Changing alarm range.

Canceling PROX alarm

| | |
|----------------|-------------|
| 6:ALARM | |
| 1:FIX | =OFF |
| 2:ANCW | =OFF 1.00nm |
| 3:PROX | =OFF 1.00nm |
| 4:XTE | =ON 1.00nm |
| 5:CDI | =ON 45° |
| 6:MESSAGE | |

Select "OFF"

| | |
|----------------|-------------|
| 6:ALARM | |
| 1:FIX | =OFF |
| 2:ANCW | =OFF 1.00nm |
| 3:PROX | =OFF 1.00nm |
| 4:XTE | =ON 1.00nm |
| 5:CDI | =ON 45° |
| 6:MESSAGE | |

Track Display

You can display track, the waypoint, course line, and cross cursor on the PLOT screen.

Displaying a cross cursor on PLOT screen

You can display a cross cursor and position it on the screen.

How to use cross cursor

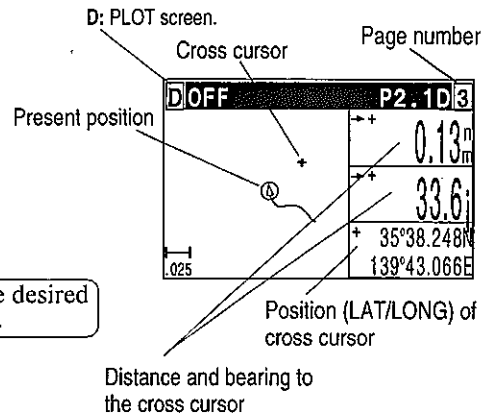
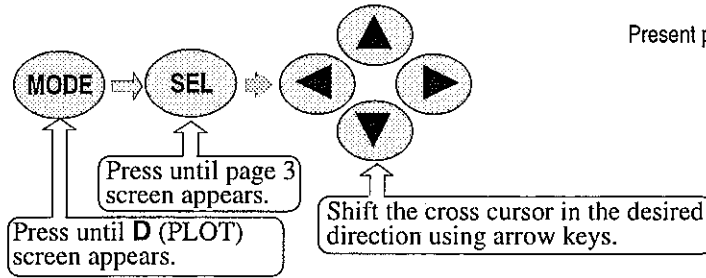

How to store cross cursor position

EVT With the cross cursor activated, press the **EVT** key to store the cross cursor position. (Note: not the present ship's position).

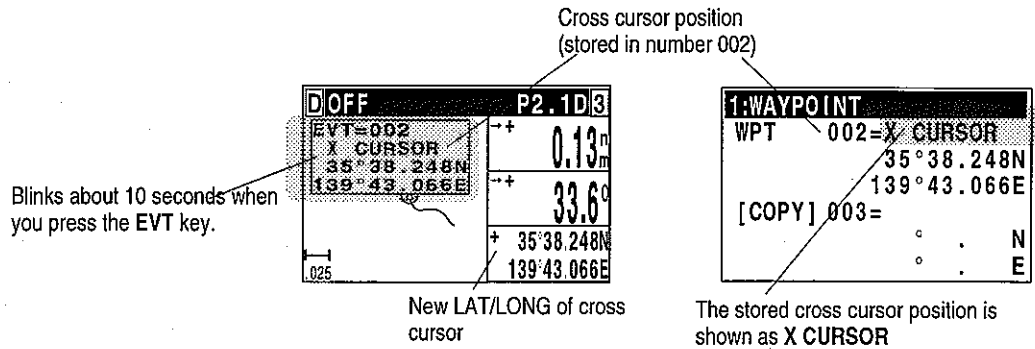

Screen scrolling

You can scroll the PLOT screen (pages: 1, 2, 3 or 4) in any direction so that your ship is always shown on the screen. If your ship moves off the screen, it will automatically return to the center of the display.

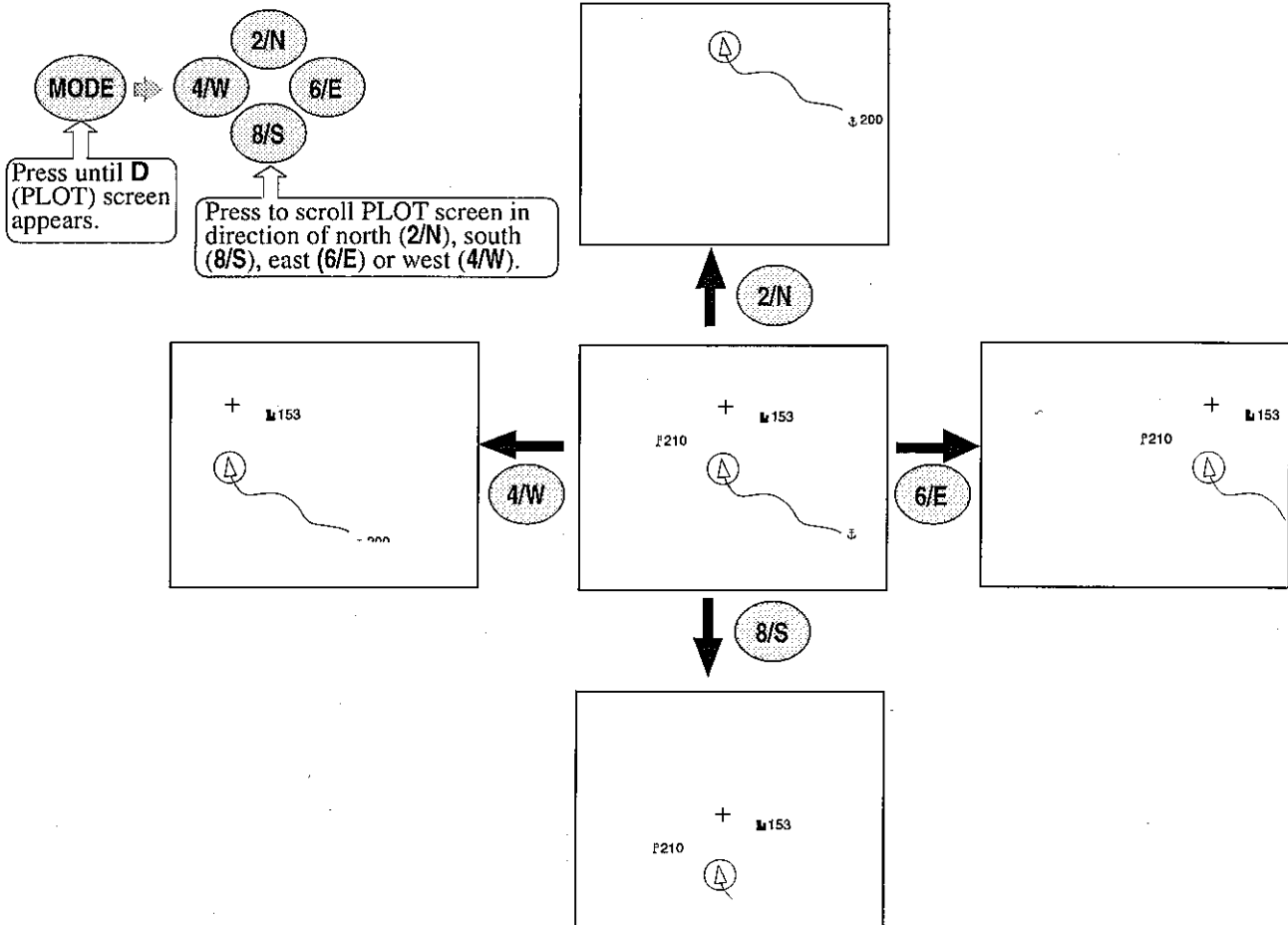

Scaling the PLOT screen

Initial scale: 0.025

You can select a display scale of PLOT (pages: 1, 2, 4) screen.

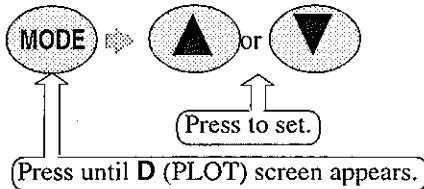

Scale indication fields

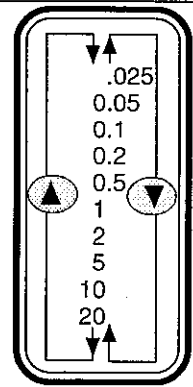
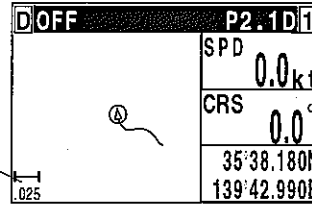

You can change the scale unit from Menu 2: UNIT (nm) of 8: INITIAL options.

Changing the setup contents

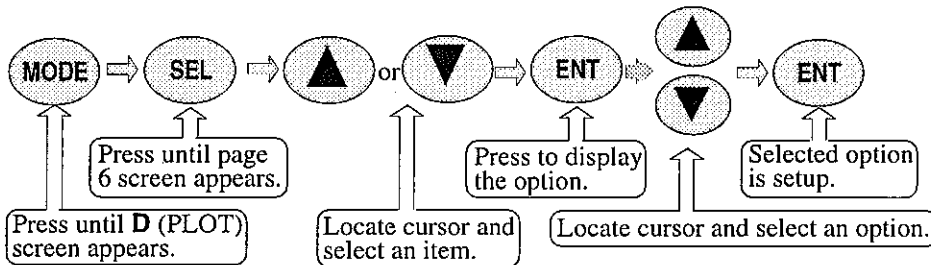

| Cursor | Page number |
|------------|-------------|
| SYMBOL = | 6 |
| EVENT = | ON |
| WAYPOINT = | ON |
| CO.LINE = | ON |
| PLOT = | 10s |
| TRACK = | ON |
| TRACK CLR | |

Changing the event symbol

To change the event symbol, place cursor on SYMBOL option and press ENT key.

Initial setup: +

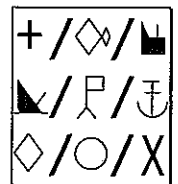

Activating event numbers (000 to 199)

Initial setup: On

Turn ON the EVENT option and you can save events (the present position marking) into memory numbers (000 to 199).

Activating event numbers (200 to 399)

Initial setup: On

Turn ON the WAYPOINT option and save events (the present position marking) into memory numbers (200 to 399).

On/off of course line (dotted lines)

Initial setup: On

During waypoint or route navigation, you can display or clear the course line from your present position to the waypoint.

Adjusting the track recording interval

Initial setup: 10 s (seconds)

To adjust the track recording interval (time or distance interval), locate cursor on PLOT option, and press ENT key.

You can set the unit of track distance interval from the Menu 2: UNIT (DST) of 8 INITIAL.

| |
|-----------|
| 10/20/30s |
| 1/3/5min |
| .1/.5/1nm |

Turning tracking off

Initial setup: On

Set the "TRACK" option to OFF to stop recording the track on PLOT screen. Your present position marking moves on the screen. Set the "TRACK" option to ON to record the track on PLOT screen.

Erasing the track

If you press the CLR key when the cursor is positioned at TRACK CLR, a confirming message (DELETE?) will appear. Press the ENT key to delete every track line currently displayed on the plotter screen.

| |
|---------|
| DELETE? |
| YES=ENT |
| NO =CLR |

How to use LOPs

Initial Setup for LOPs Display

Measured longitude and latitude can be translated into Loran C, Loran A or Decca LOPs mode. To turn on the LOPs mode, the following initial setup is required.

Selecting LOP (Loran C, Loran A or Decca)

Note: If the power is already ON, turn it OFF and turn it ON again.

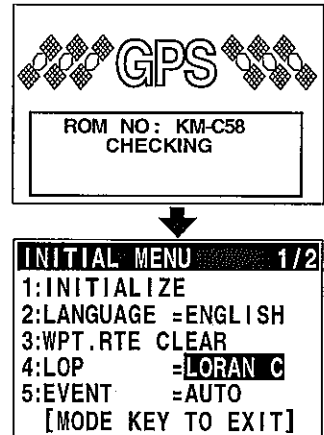
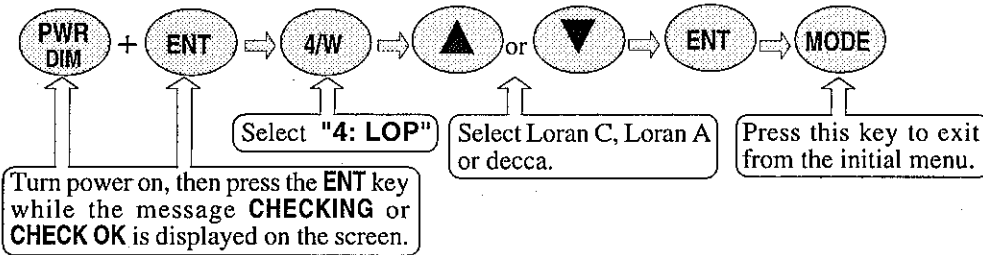

Setting the chain and secondary stations to be displayed

Select the chain and secondary stations to be displayed. Settings depend on the LOPs mode to be used as described below.

Setting chain and secondary stations in Loran C LOPs mode

You can convert your GPS present position and stored memory data (waypoints and events) from LAT/LONG into Loran C LOPs.

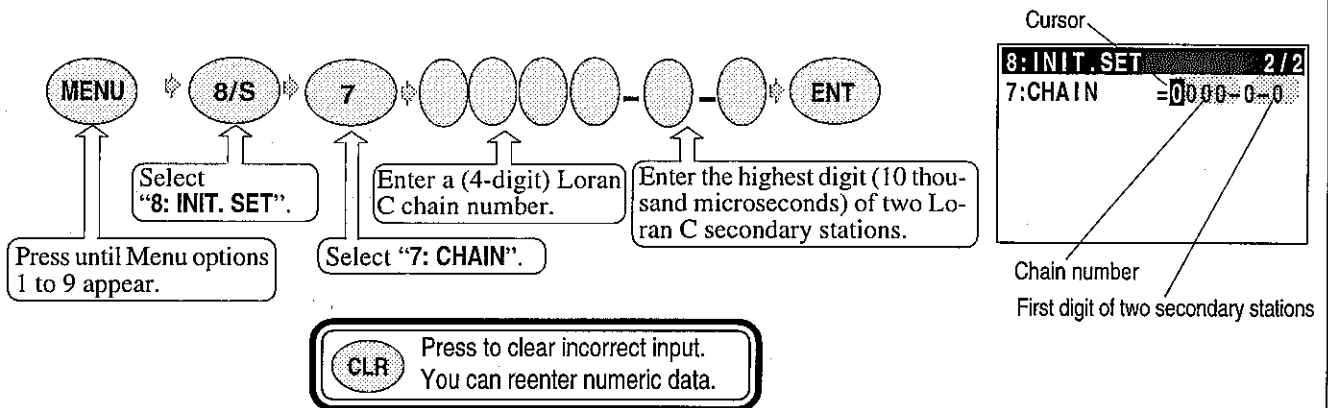

Specifying combinations of secondary stations in Loran A LOPs mode

You can convert your present position given by GPS and stored position data (waypoints and event data) from LAT/LONG into Loran A LOPs.

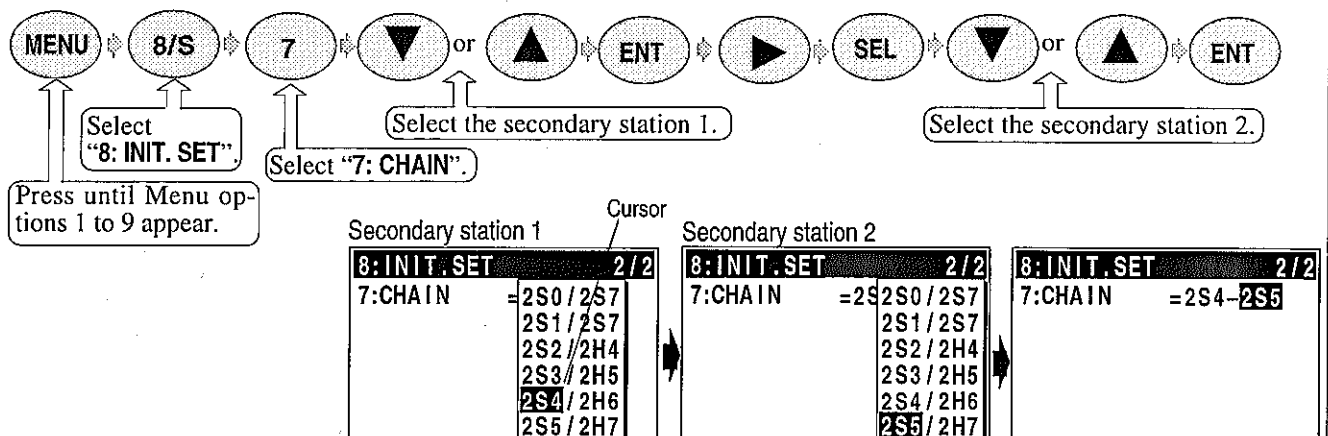

Automatic chain selecting in Decca LOPs mode

You can convert your GPS present position and stored position memory (waypoints and event data) from LAT/LONG into Decca LOPs by automatic selection of Decca chain.

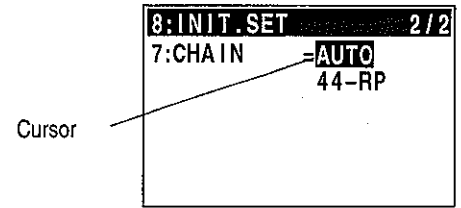
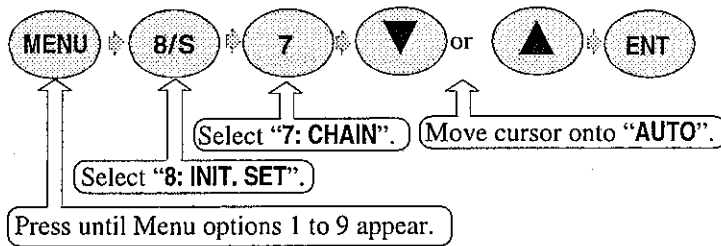

Manual chain selecting in Decca LOPs mode

You can convert both your present position given by GPS and stored position data (waypoints and event data) from LAT/LONG into Decca LOPs.

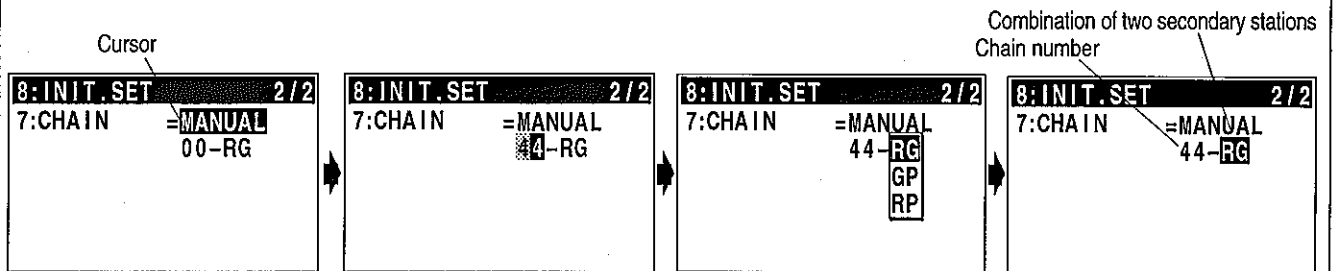
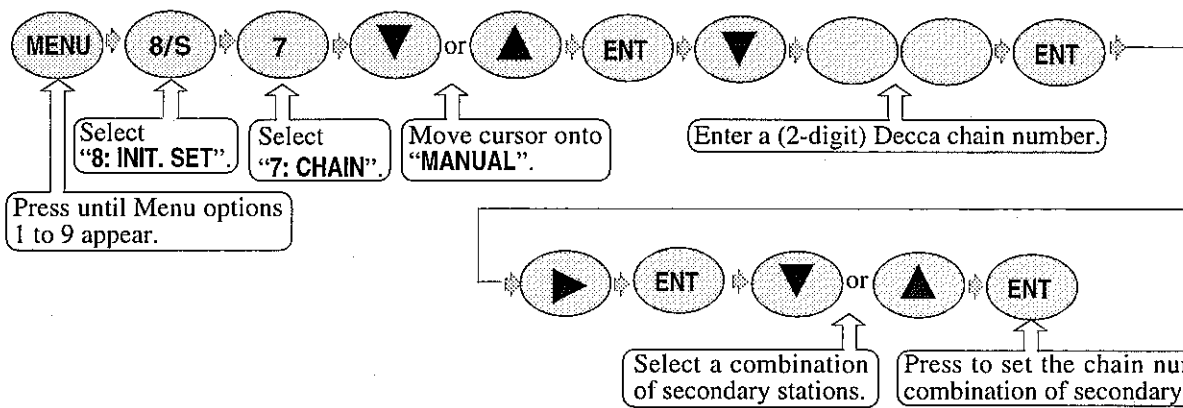

Registering a position in LOPs

Following describes the procedure for replacing LAT/LONG display with LOP and registering a position in LOP.

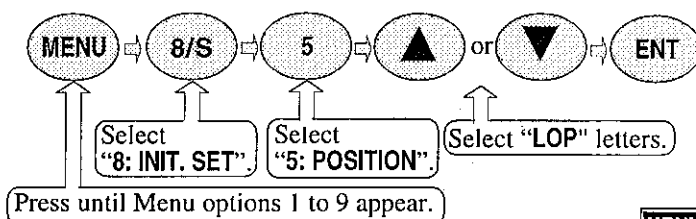

MODE You can exit from the menu by displaying A (NAV 1), B (NAV 2), C (NAV 3) or D (PLOT) screen from the MODE key.

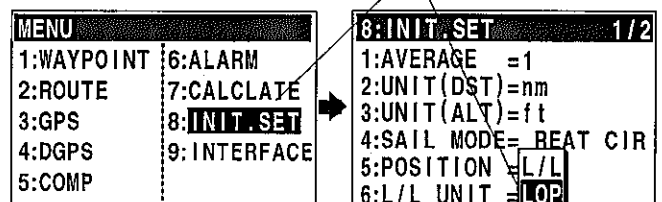

Storing waypoints (LOPs data)

Storing a new position or updating an existing one

Up to 200 waypoints can be stored in memory. As 200 points (numbers 000 and 199) are reserved for MOB and event registration, you can use 200 to 399 (total of 200 points) to store waypoints.

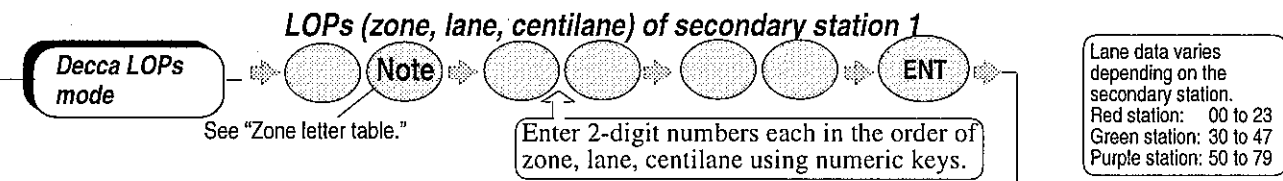
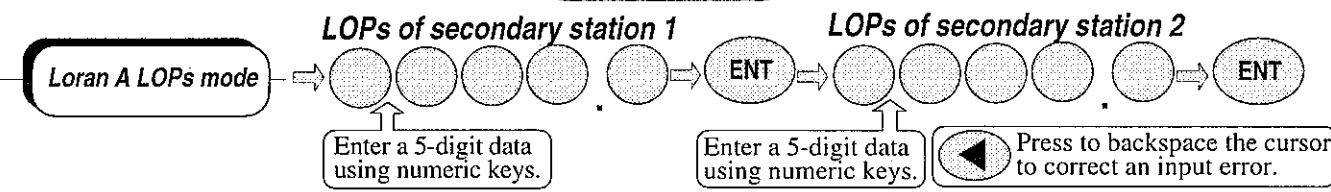
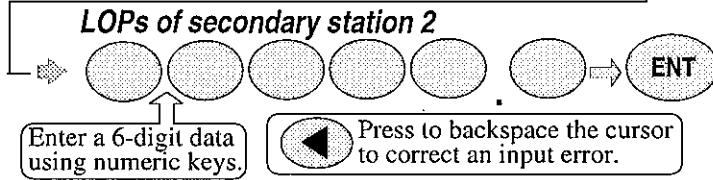
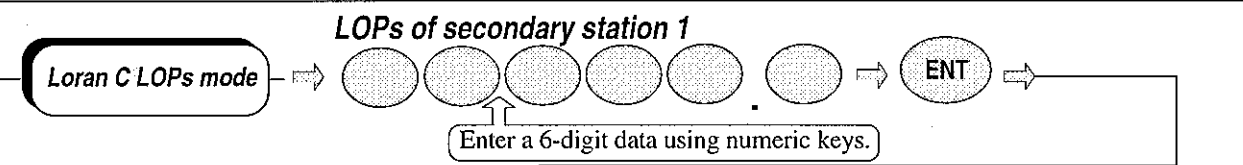
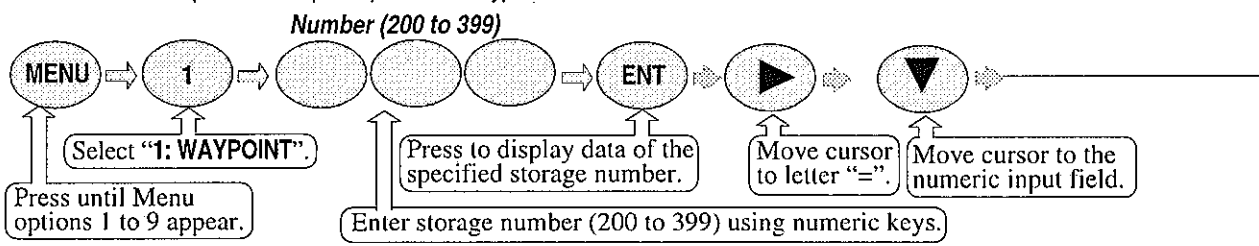

Lane data varies depending on the secondary station.
 Red station: 00 to 23
 Green station: 30 to 47
 Purple station: 50 to 79

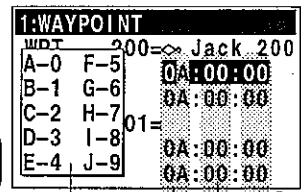
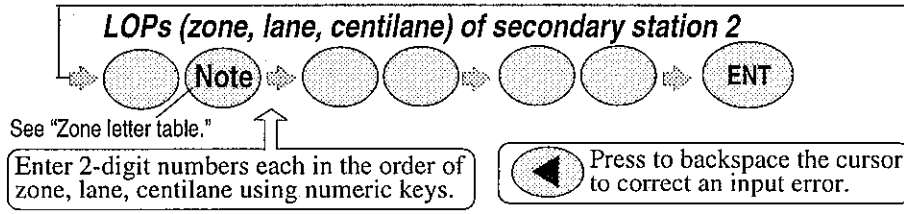

Zone letter table Centilane
Lane
Zone

| | No. | Code |
|-------------------|-----|------|
| EUROPE | | |
| South Baltic | 00 | 0A |
| Vestlandet | 01 | 0E |
| Southwest British | 02 | 1B |
| Northumbrian | 03 | 2A |
| Holland | 04 | 2E |
| North British | 05 | 3B |
| Lofoten | 06 | 3E |
| German | 07 | 3F |
| North Baltic | 08 | 4B |
| Northwest Spanish | 09 | 4C |
| Trondelag | 10 | 4E |
| English | 11 | 5B |
| North Bothnian | 12 | 5F |
| South Spanish | 13 | 6A |
| North Scottish | 14 | 6C |
| Gulf of Finland | 15 | 6E |
| Danish | 16 | 7B |

| | No. | Code |
|---------------------|-----|------|
| Irish | 17 | 7D |
| Finnmark | 18 | 7E |
| French | 19 | 8B |
| South Bothnian | 20 | 8C |
| Hebridean | 21 | 8E |
| Frisian Islands | 22 | 9B |
| Helgeland | 23 | 9E |
| Skagerrak | 24 | 10B |
| PERSIAN GULF | | |
| North Persian | 25 | 5C |
| South Persian | 26 | 1C |
| INDIAN OCEAN | | |
| Bombay | 27 | 7B |
| Calcutta | 28 | 8B |
| Bangladesh | 29 | 6C |
| JAPAN | | |
| Hokkaido | 30 | 9C |
| North Kyushu | 32 | 7C |

| | No. | Code |
|-----------------------------|-----|------|
| SOUTH AFRICA | | |
| Namaqua | 33 | 4A |
| Cape | 34 | 6A |
| Eastern province | 35 | 8A |
| NORTH WEST AUSTRALIA | | |
| Dampier | 36 | 8E |
| Port Hedland | 37 | 4A |
| CANADA | | |
| Anticosti | 38 | 9C |
| Newfoundland | 39 | 2C |
| Cabot Straits | 40 | 6B |
| Nova Scotia | 41 | 7C |
| INDIAN OCEAN | | |
| Salaya | 42 | 2F |
| SOUTH AFRICA | | |
| Southwest Africa | 44 | 9C |
| Natal | 45 | 10C |

For the following operations, refer to the "Storing waypoints (LAT/LONG) data"

- "Registering additional comments" (see page 13).
- "Copying a position" (see page 14)
- "Changing the comment I.D." (see page 14)
- "Erasing a single waypoint" (see page 14)

Menu 5: Correcting your position (LOPs)

You can compensate your GPS present position in the following two ways:

- Enter the LOPs of your actual position using numeric keys.
- Enter the correction amount to use.

Note: The LOP correction is ineffective in latitude and longitude mode.

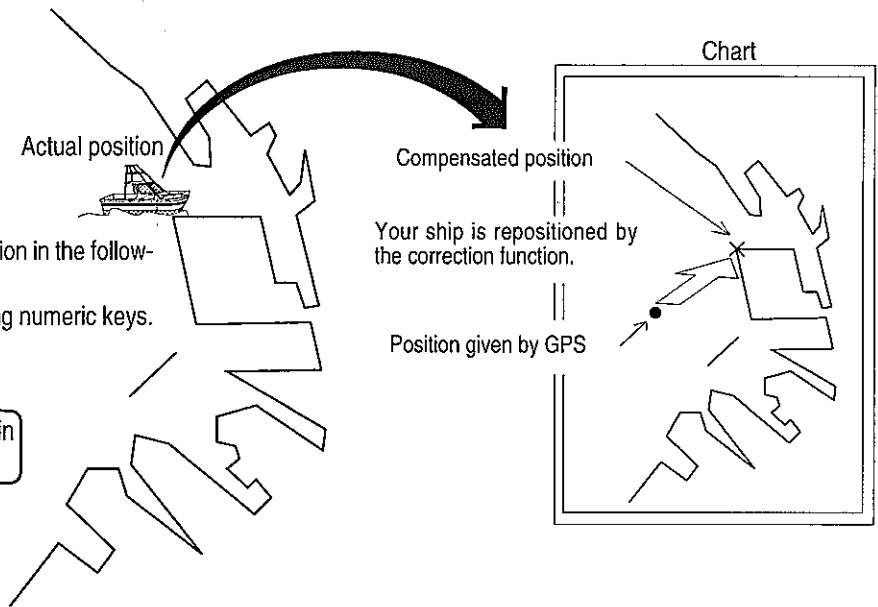

Direct entry of actual position data

Correction by Loran C LOPs data entry

When your position is indicated in Loran C LOPs mode, you can correct it by entering the Loran C LOPs correction amount.

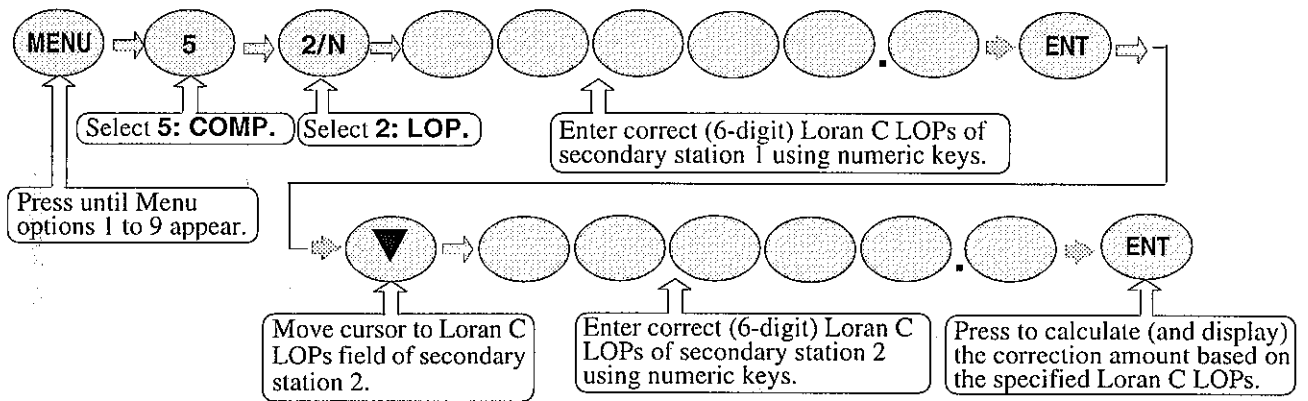

CLR Press to clear incorrect input. You can reenter numeric data.

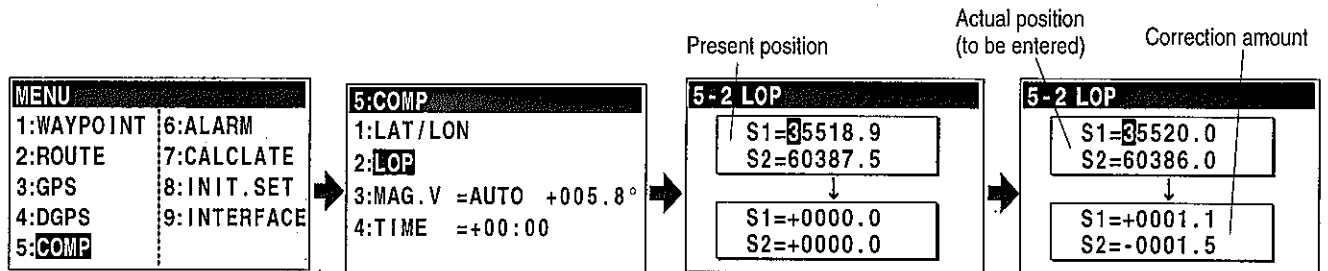

| Present position (GPS fix) | Actual position (to be entered) | Correction amount |
|----------------------------------|----------------------------------|----------------------------------|
| Secondary station 1 35518.9 μsec | Secondary station 1 35520.0 μsec | Secondary station 1 +0001.1 μsec |
| Secondary station 2 60387.5 μsec | Secondary station 2 60386.0 μsec | Secondary station 2 -0001.5 μsec |

Correction by Loran A LOPs data entry

When your position is indicated in Loran A LOPs mode, you can correct it by entering the Loran A LOPs correction amount.

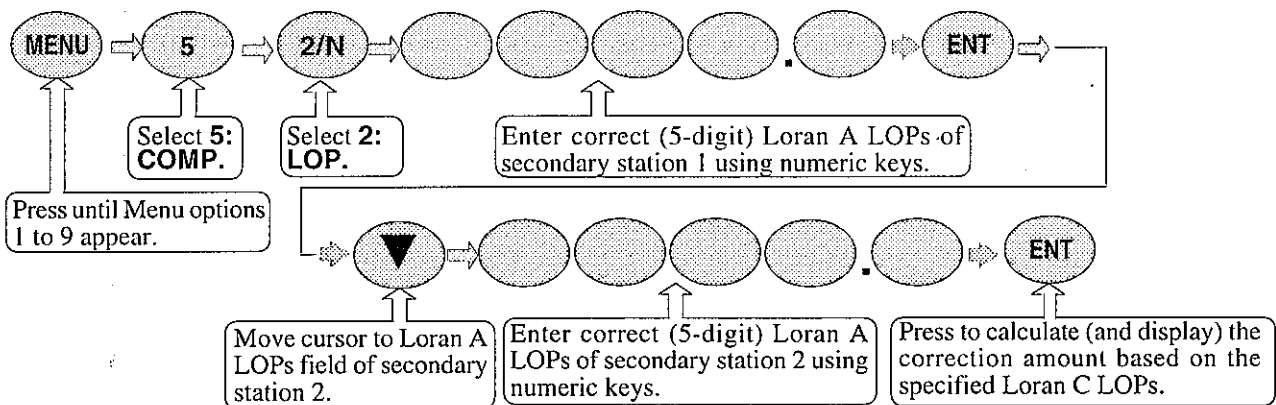

CLR Press to clear incorrect input. You can reenter numeric data.

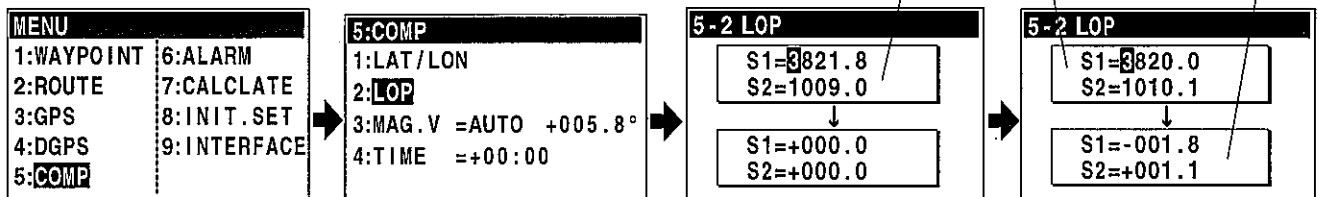

| Present position (GPS fix) | Actual position (to be entered) | Correction amount |
|---------------------------------|---------------------------------|----------------------------------|
| Secondary station 1 3821.8 msec | Secondary station 1 3820.0 msec | Secondary station 1 -001.8 msec |
| Secondary station 2 1009.0 msec | Secondary station 2 1010.0 msec | Secondary station 2 +001.1 msec. |

Correction by Decca LOPs data entry

When your position is indicated in Decca LOPs mode, you can correct it by entering the Decca LOPs correction amount.

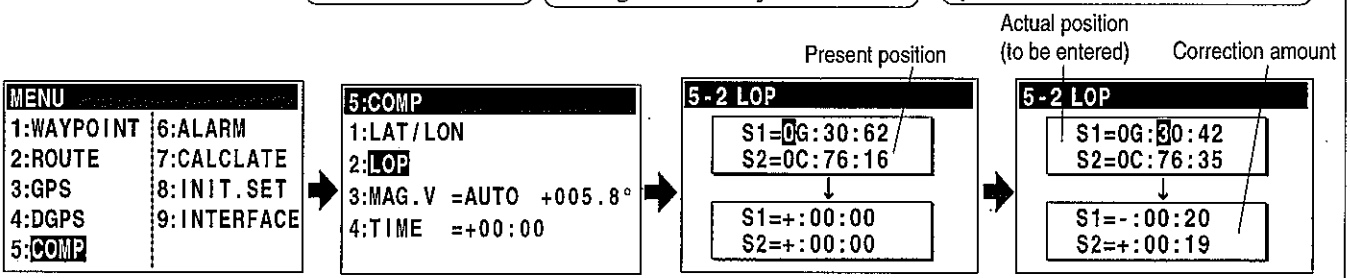
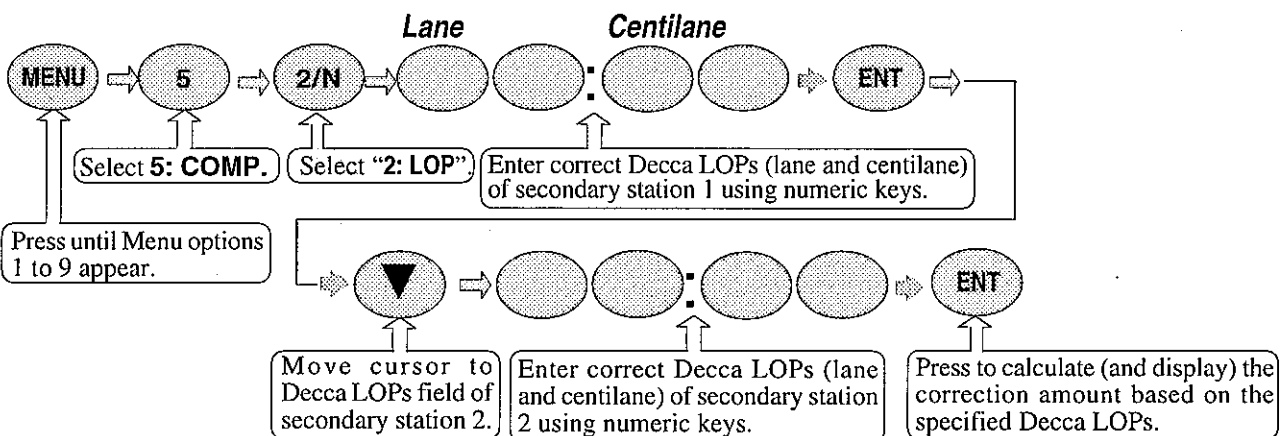

| Present position (GPS fix) | Actual position (to be entered) | Correction amount |
|------------------------------|---------------------------------|---------------------------------|
| Green station 0G:30:62 μsec | Secondary station 1 30:42 | Secondary station 1 -00:20 μsec |
| Purple station 0C:76:16 μsec | Secondary station 2 76:35 | Secondary station 2 +00:19 μsec |

Entry of correction amount

Correction by Loran C LOPs data entry

When your position is indicated in Loran C LOPs mode, you can correct it by entering the Loran C LOPs correction amount.

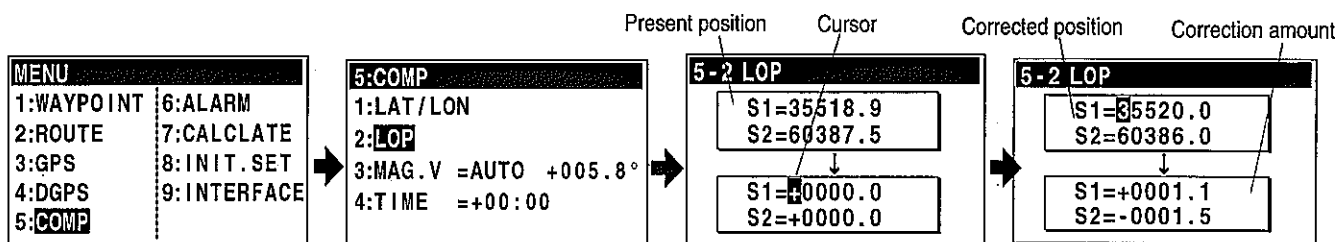
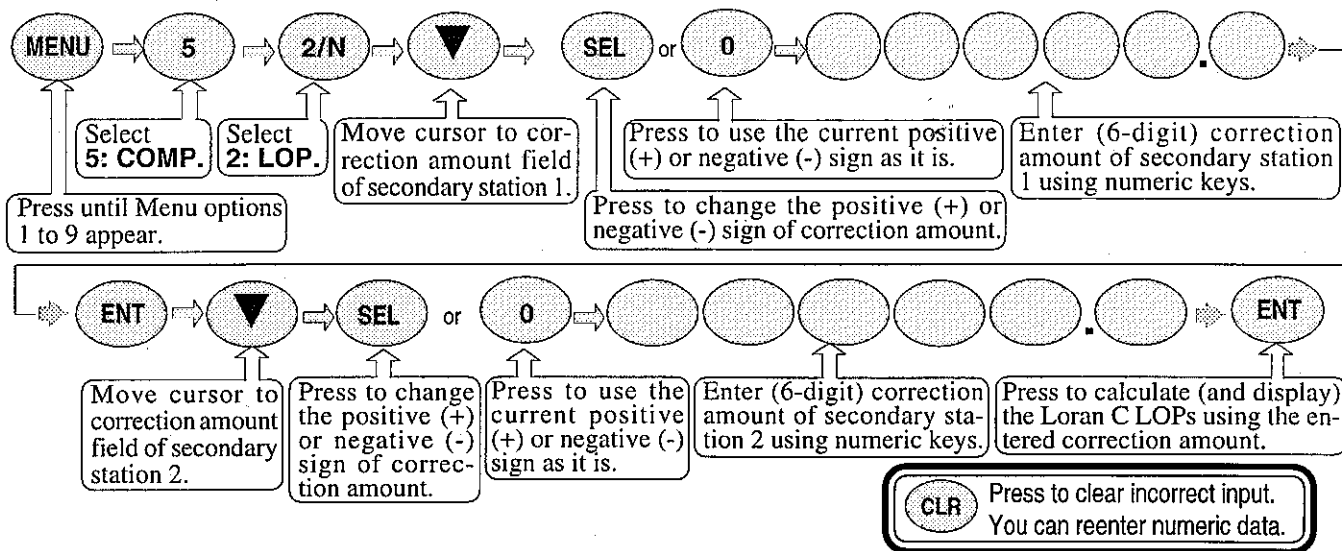

| Correction amount (to be entered) | Present position | Correction position |
|--|---------------------------------------|---------------------------------------|
| Secondary station 1 +0001.1 μ sec | Secondary station 1 35518.9 μ sec | Secondary station 1 35520.0 μ sec |
| Secondary station 2 -0001.5 μ sec | Secondary station 2 60387.5 μ sec | Secondary station 2 60386.0 μ sec |

Correction by Loran A LOPs data entry

When your position is indicated in Loran A LOPs mode, you can correct it by entering the Loran A LOPs correction amount.

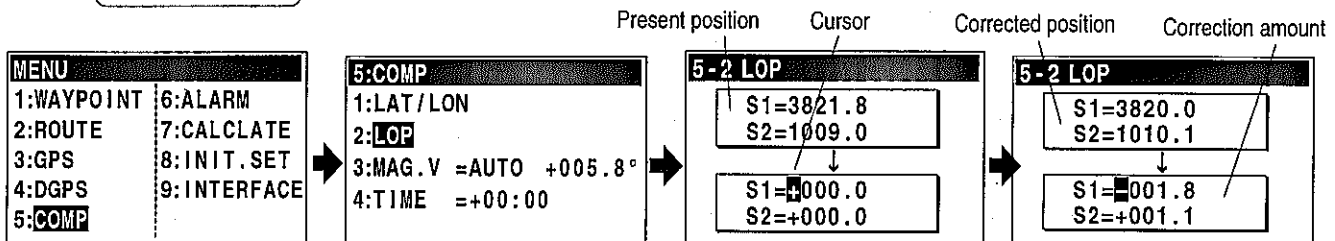
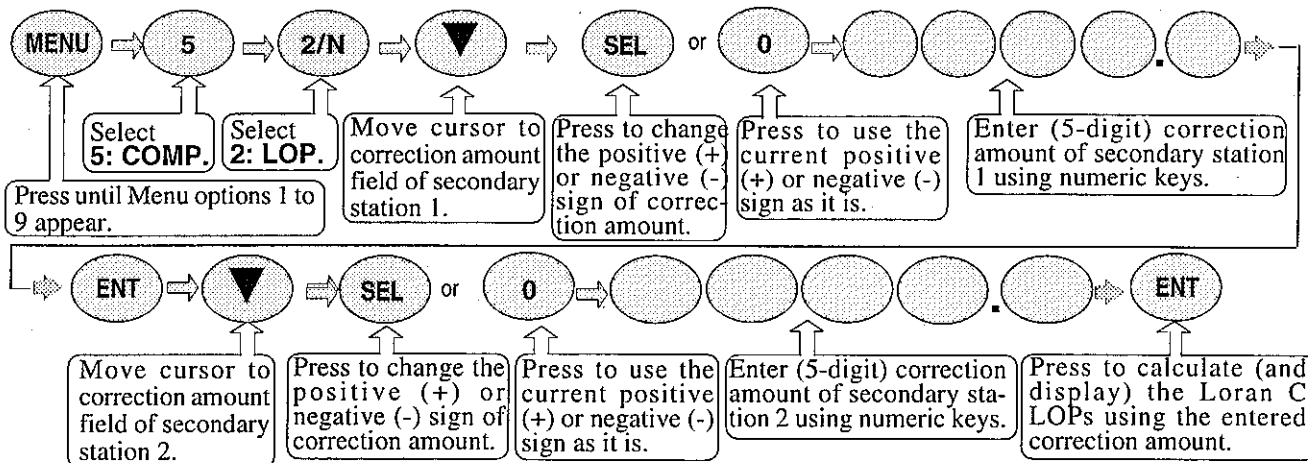

| Correction amount (to be entered) | Present position | Correction position |
|--|--------------------------------------|--------------------------------------|
| Secondary station 1 - 001.8 μ sec | Secondary station 1 3821.8 μ sec | Secondary station 1 3820.0 μ sec |
| Secondary station 2 + 001.1 μ sec | Secondary station 2 1009.0 μ sec | Secondary station 2 1010.1 μ sec |

Correction by Decca LOPs data entry

When your position is indicated in Decca LOPs mode, you can correct it by entering the Decca LOPs correction amount.

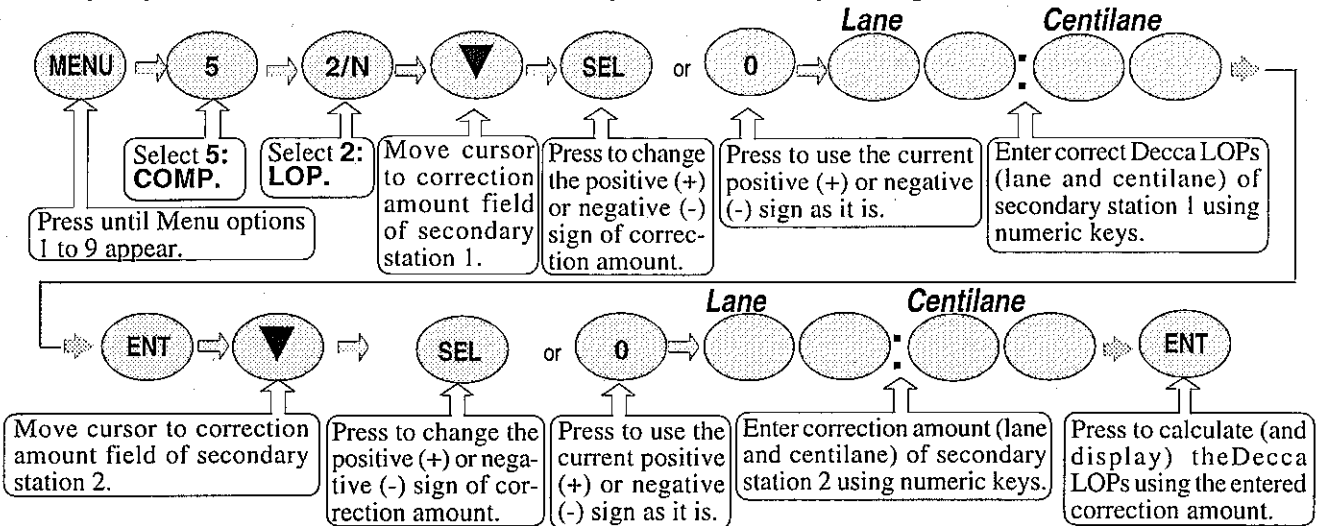

CLR Press to clear incorrect input. You can reenter numeric data.

| Present position | Cursor | Corrected position | Correction amount |
|--|---|--|--|
| MENU 1:WAYPOINT 6:ALARM 2:ROUTE 7:CALCLATE 3:GPS 8:INIT.SET 4:DGPS 9:INTERFACE 5:COMP | 5:COMP 1:LAT/LON 2:LOP 3:MAG.V =AUTO +005.8° 4:TIME =+00:00 | 5-2 LOP S1=0G:30:62 S2=0C:76:16 S1=0:00:00 S2=+00:00 | 5-2 LOP S1=0G:30:42 S2=0C:76:35 S1=0:00:20 S2=+00:19 |
| Correction amount (to be entered) | Present position | Correction position | |
| Secondary station 1 -00:20 μsec | Green station 0G:30:62 μsec | Secondary station 1 0G:30:42 | |
| Secondary station 2 +00:19 μsec | Purple station 0C:76:16 μsec | Secondary station 2 0C:76:35 | |

Checking the correction amount

You can check the correction amount as follows:

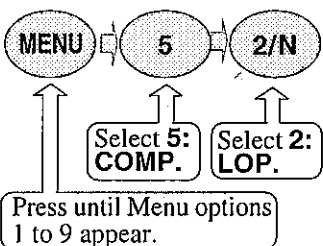

Loran C LOPs mode

| |
|--------------------------|
| 5-2 LOP |
| S1=5520.0 S2=60386.0 |
| S1=+0001.1 S2=-0001.5 |

Your position has been corrected by 1.5 microseconds to the secondary.
Your position has been corrected by 1.1 microseconds to the other secondary.

Loran A LOPs mode

| |
|------------------------|
| 5-2 LOP |
| S1=820.0 S2=1010.1 |
| S1=-001.8 S2=+001.1 |

Your position has been corrected by 1.1 microseconds to the other secondary.
Your position has been corrected by 1.8 microseconds to the secondary.

Decca LOPs mode

| |
|----------------------------|
| 5-2 LOP |
| S1=0G:30:42 S2=0C:76:35 |
| S1=-00:20 S2=+00:19 |

Your position has been corrected by 0.19 lane to the secondary.
Your position has been corrected by 0.20 lane to the other secondary.

Canceling position correction

You can cancel any position correction as follows:

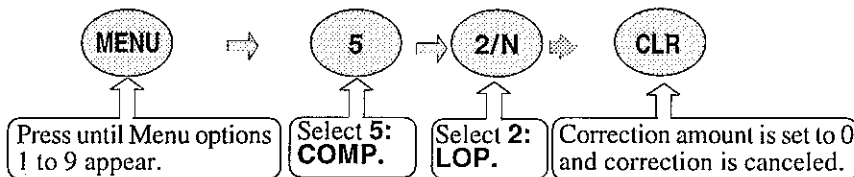

Loran C LOPs mode

| |
|--------------------------|
| 5-2 LOP |
| S1=5518.9 S2=60387.5 |
| S1=+0000.0 S2=+0000.0 |

Loran A LOPs mode

| |
|------------------------|
| 5-2 LOP |
| S1=821.8 S2=1009.0 |
| S1=+000.0 S2=+000.0 |

Decca LOPs mode

| |
|----------------------------|
| 5-2 LOP |
| S1=0G:30:62 S2=0C:76:16 |
| S1=+00:00 S2=+00:00 |

Position correction has been cleared.

Menu 7 : Calculating LOPs based on LAT/LONG data

Calculating Loran C LOPs based on LAT/LONG data

You can enter a Loran C chain number and the first digit of two secondary stations, NAVIGATOR calculates the Loran C LOPs based on the specified LAT/LONG data and displays the LOP values.

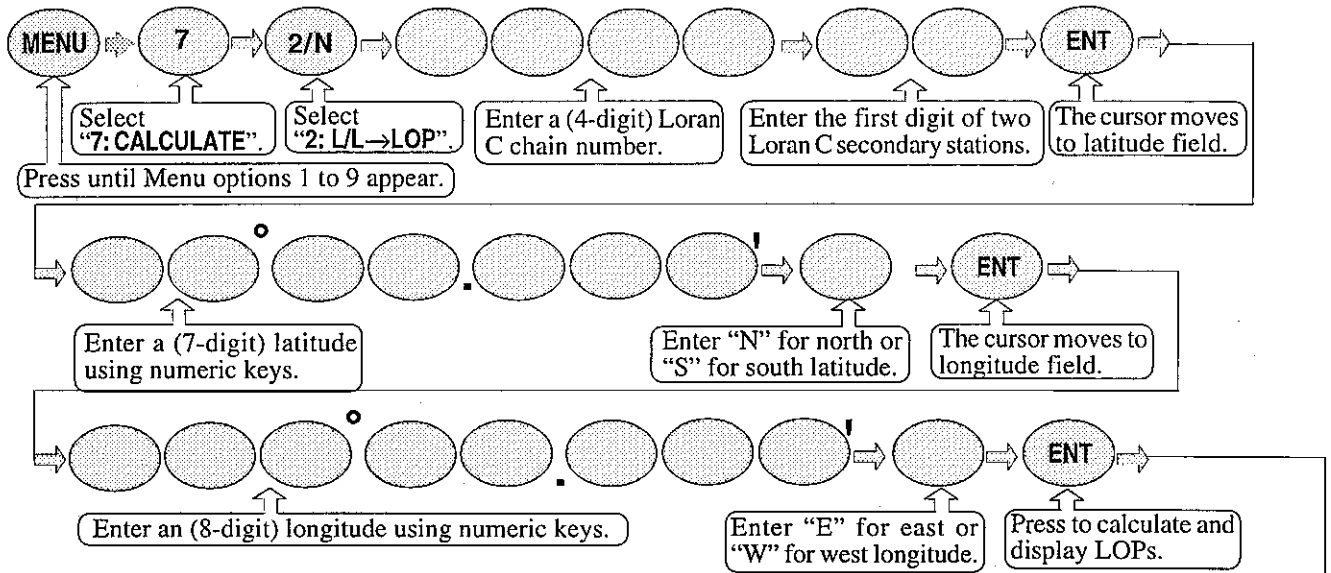

Chain number and the first digit of two secondary stations used for LOPs conversion

| MENU | |
|------------|-------------|
| 1:WAYPOINT | 6:ALARM |
| 2:ROUTE | 7:CALCULATE |
| 3:GPS | 8:INIT.SET |
| 4:DGPS | 9:INTERFACE |
| 5:COMP | |

| 7:CALCULATE | |
|-------------------|--|
| 1:2 POINT | |
| 2:L/L→LOP | |
| 3:NAVIGATION PLAN | |

| 7-2:L/L→LOP 1/2 | |
|-----------------|--------------|
| CHAIN | =8930-1-4 |
| LAT | = 35°38.000N |
| LON | =139°47.000E |
| L/L→LOP: S1 | =20081.7 |
| L/L→LOP: S2 | =41769.9 |

LAT/LONG data used for LOPs conversion

Converted Loran C LOPs

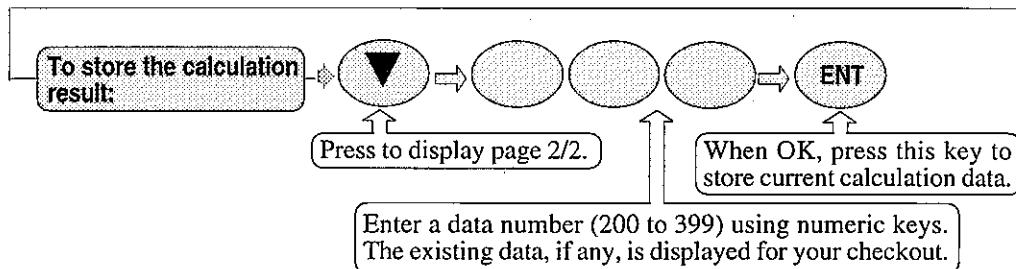

| 7-2:L/L→LOP 2/2 | |
|-----------------|----------|
| L/L→LOP: S1 | =20081.7 |
| L/L→LOP: S2 | =41769.9 |
| WPT | [000] |
| | ° . N |
| | ° . E |

| 7-2:L/L→LOP 2/2 | |
|-----------------|---------------|
| L/L→LOP: S1 | =20081.7 |
| L/L→LOP: S2 | =41769.9 |
| WPT | [X L/L→LOP] |
| | 35°38.000N |
| | 139°47.000E |

Data currently stored ("X L/L - LOP" : fixed.)

Specified data number

Data currently stored ("X L/L - LOP" : fixed.)

LAT/LONG mode

| 1:WAYPOINT | |
|------------|---------------|
| WPT | 300=X L/L→LOP |
| | 35°38.000N |
| | 139°47.000E |
| [COPY] | 301= |
| | ° . N |
| | ° . E |

Loran C LOPs mode

| 1:WAYPOINT | |
|------------|---------------|
| WPT | 300=X L/L→LOP |
| | 20081.7 |
| | 41769.9 |
| [COPY] | 301= |
| | ° . N |
| | ° . E |

Caution Do not use the converted LOPs position data for waypoint or route navigation because of likely conversion errors. Accuracy of converted positions can be off 1/4 mile or more.

You can switch the display between LAT/LONG and LOPs modes from Menu (using "8: INIT.SET" and "5: POSITION" option).

Calculating Loran A LOPs based on LAT/LONG data

When you enter a combination of two secondary stations of Loran A, NAVIGATOR calculates the Loran A LOPs based on the specified LAT/LONG data and displays the LOP values.

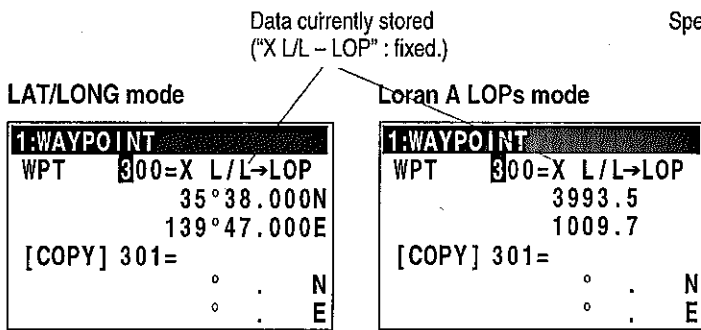
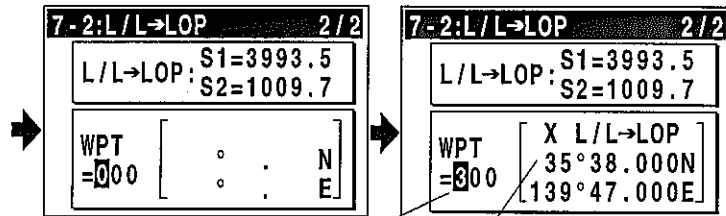
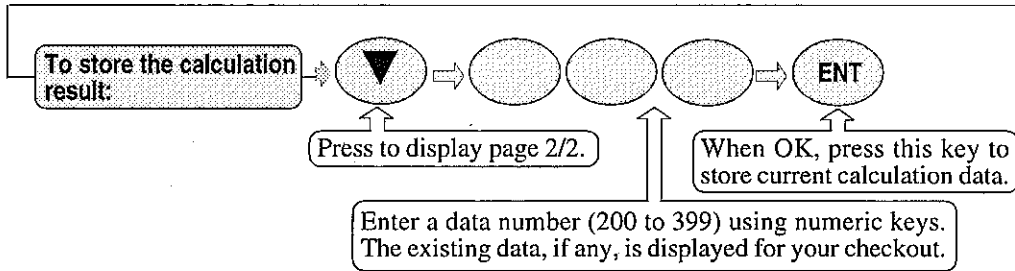
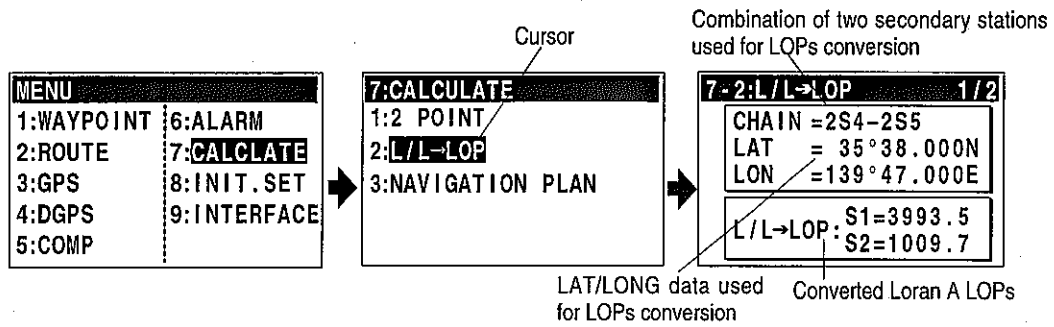
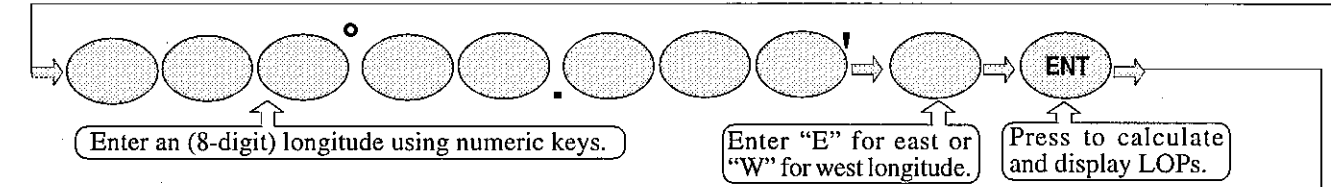
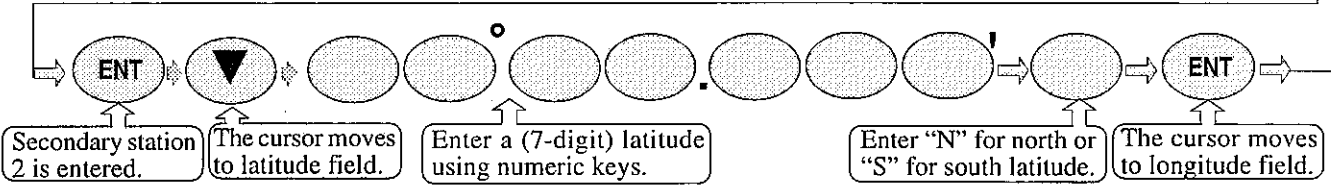
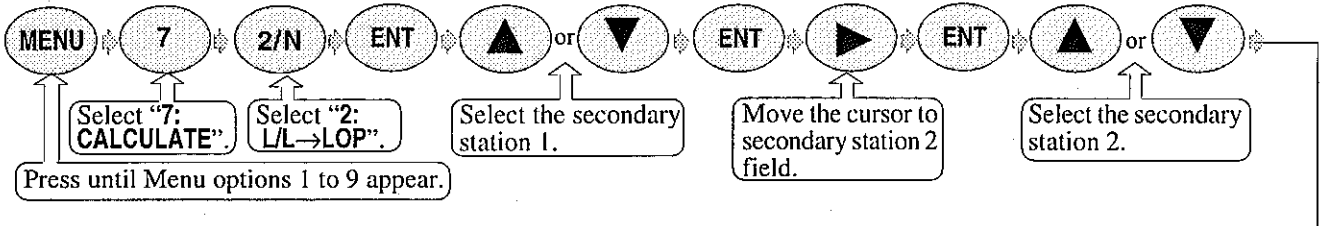

Caution Do not use the converted LOPs position data for waypoint or route navigation because of likely conversion errors. Accuracy of converted positions can be off 1/4 mile or more.

You can switch the display between LAT/LONG and LOPs modes from Menu (using "8: INIT.SET" and "5: POSITION" option).

Calculating Decca LOPs based on LAT/LONG data

When you enter a Decca chain number and a combination of two secondary stations, NAVIGATOR calculates the Decca LOPs based on the specified LAT/LONG data and displays the LOP values.

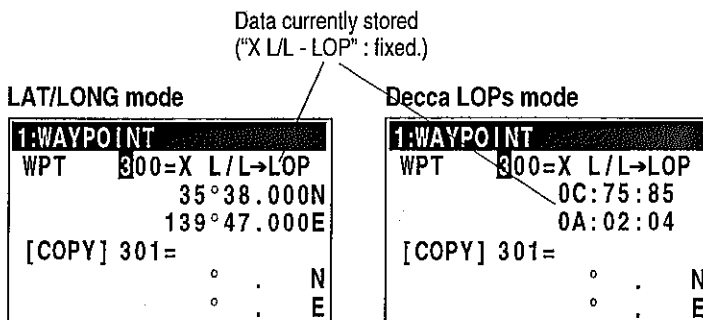
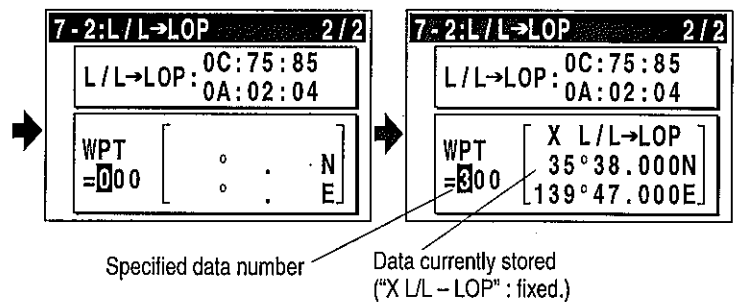
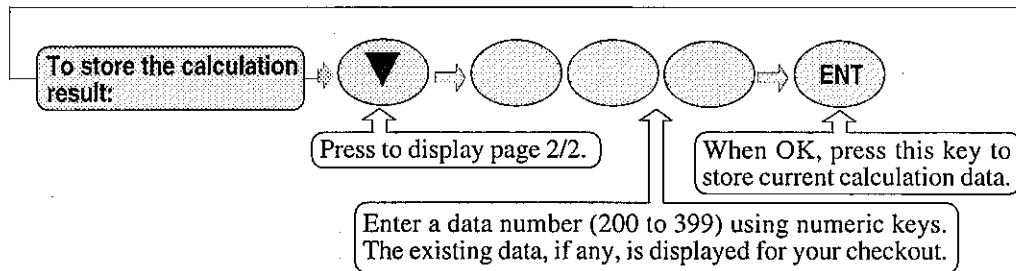
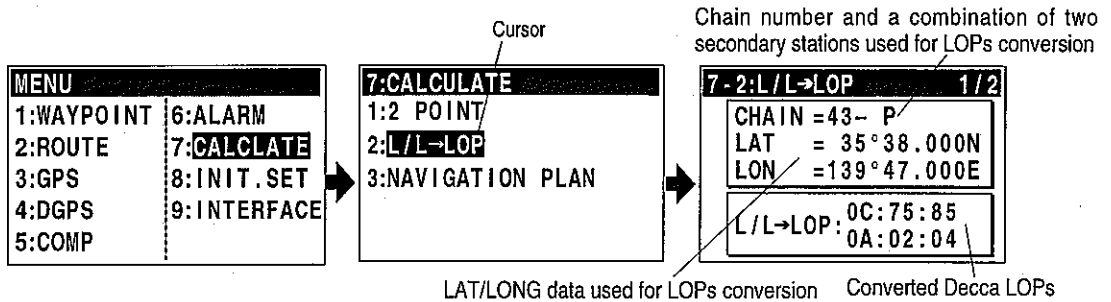
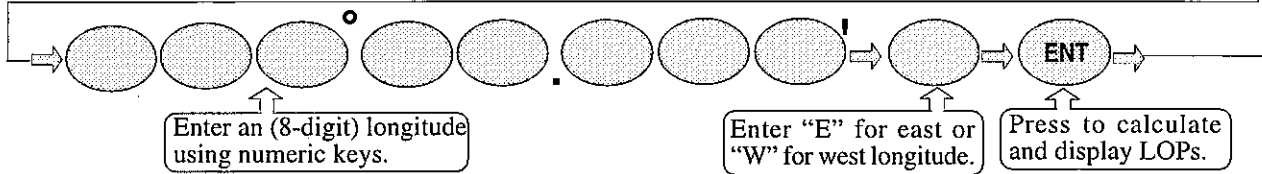
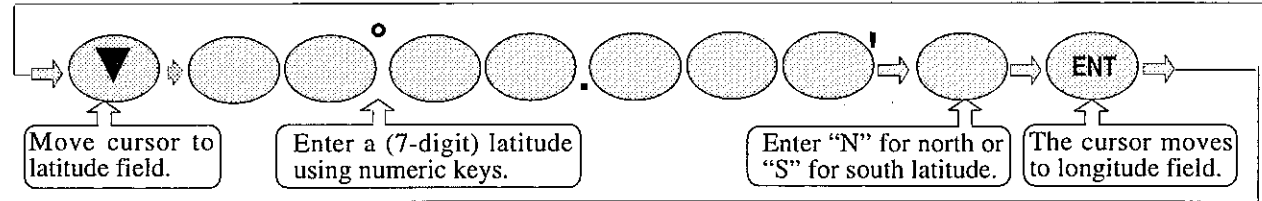
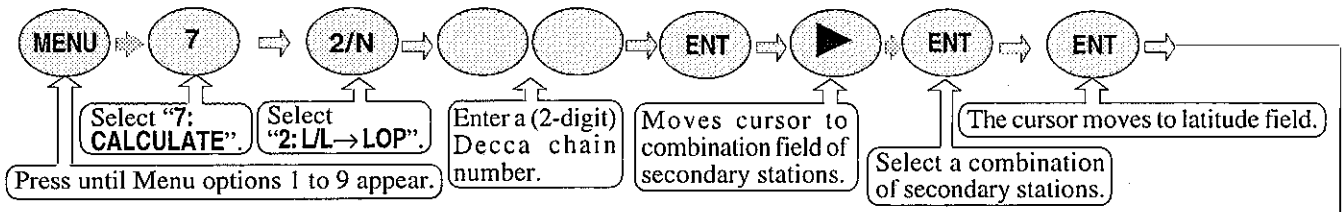

Caution Do not use the converted LOPs position data for waypoint or route navigation because of likely conversion errors. Accuracy of converted positions can be off 1/4 mile or more.

You can switch the display between LAT/LONG and LOPs modes from Menu (using "5: POSITION" of "8: INITIAL" option).

Setup Procedure

Menu options

| MENU | |
|------------|-------------|
| 1:WAYPOINT | 6:ALARM |
| 2:ROUTE | 7:CALCLATE |
| 3:GPS | 8:INIT.SET |
| 4:DGPS | 9:INTERFACE |
| 5:COMP | |

| 1:WAYPOINT | |
|------------|-------|
| WPT | 000= |
| | ° . N |
| | ° . E |
| [COPY] | 001= |
| | ° . N |
| | ° . E |

1. Waypoints

Store, edit, copy and erase waypoints (see pages 12 to 14 and 35 to 36).

| 2:ROUTE | |
|---------------------|--|
| 1:RTE EDIT | |
| 2:WPT CHANGE=CIRCLE | |
| 3:WPT DATA =NEXT | |
| (Rnn.WPL) | |

2. Route

(See pages 21 to 24, and 62.)

Store and erase a route.
Forward/backward navigation selection
Automatic route switching
Waypoint data switching

| 3:GPS | |
|-----------------|--|
| 1:GPS MONITOR | |
| 2 FIX MODE=3D | |
| 3 DATUM =WGS-84 | |
| 4 ANT.H =0000ft | |
| 5 DOP MASK=07 | |
| 6 ELV.MASK=10 | |

3. GPS

Display GPS satellite status.
Switch (2- and 3-dimensional) positioning modes.
Select datum.
Set antenna height (above sea level).
See DOP value to limit fix data
Set satellite elevation angle limit.

GPS NAVIGATOR

| 4:DGPS 1/2 | |
|----------------------|--|
| 1:DGPS MODE=AUTO | |
| 2 BAUD RATE=4800 | |
| 3 TIMEOUT =100s | |
| 4 STN SEL =AUTO | |
| 5 FREQUENCY=000.0kHz | |
| 6 BIT RATE =200bps | |

4. Differential GPS (DGPS)

Select DGPS mode.
Set DGPS input baud rate.
Set DGPS timeout.
Select beacon station
Set beacon frequency

DGPS NAVIGATOR

| 4:DGPS 1/2 | |
|----------------------|--|
| 1:DGPS MODE=AUTO | |
| 2 BAUD RATE=4800 | |
| 3 TIMEOUT =100s | |
| 4 STN SEL =AUTO | |
| 5 FREQUENCY=000.0kHz | |
| 6 BIT RATE =200bps | |

Store beacon station (DGPS NAVIGATOR only selectable)

| 4:DGPS 2/2 | |
|----------------|--|
| 7:DGPS MONITOR | |

Monitor DGPS data.

| 5:COMPENSATION | |
|-----------------------|--|
| 1:LAT/LON | |
| 2:LOP | |
| 3:MAG.V =AUTO +005.8° | |
| 4:TIME =+00:00 | |

5. Corrections.

Position correction (LAT/LONG, LOPs)
Compass correction
Time difference

| 6:ALARM | |
|--------------------|--|
| 1:FIX =OFF | |
| 2:ANCW =OFF 1.00nm | |
| 3:PROX =ON 1.00nm | |
| 4:XTE =ON 1.00nm | |
| 5:CDI =ON 45° | |
| 6:MESSAGE | |

6. Alarm (See pages 29 to 31)

GPS fix alarm, DGPS fix alarm
Anchor watch alarm
Proximity alarm
XTE alarm
CDI alarm
Alarm message

| 7:CALCULATE | |
|-------------------|--|
| 1:POINT | |
| 2:L/L-LOP | |
| 3:NAVIGATION PLAN | |

7. Calculation

Distance and bearing between two points
LAT/LONG into LOPs data conversion
Calculation of estimated time length from the current position to the destination, or required speed.

| 8:INIT.SET 1/2 | |
|--------------------------------------|--|
| 1:AVERAGE = <input type="checkbox"/> | |
| 2:UNIT (DST)=nm | |
| 3:UNIT (ALT)=ft | |
| 4:SAIL MODE=GREAT CIR | |
| 5:POSITION =L/L | |
| 6:L/L UNIT =.001 | |

8. Initial value setup

Set average constants.
Select distance/speed units.
Select antenna height (above sea level) units.
Select navigation mode.
Select position display mode (LAT/LONG, LOPs)
Select LAT/LONG display digits
Set chain.

| 8:INIT.SET 2/2 | |
|--|--|
| 7:CHAIN = <input type="checkbox"/> 000-0-0 | |

| 9:INTERFACE | |
|--------------------|--|
| 1:FORMAT=0183 | |
| 2:0183 EDIT | |
| [Only 0183 usable] | |

9. Interfacing

Select output format (DGPS NAVIGATOR only selectable).
Edit the output format (NMEA-0183).

| 9:INTERFACE | |
|---------------|--|
| 1:FORMAT=0183 | |
| 2:0183 EDIT | |

Selecting a menu option

You can select an option from Menu in two ways: by direct numeric key entry and by cursor shifting. This manual explains how to enter numeric values for easy understanding, but you can also use the cursor for option selection.

Monitoring GPS satellite signal reception

You can monitor the signal status from GPS satellites. The signals from 3 satellites are used for two-dimensional positioning, but signals from 4 or more satellites are required for three-dimensional positioning.

Satellite signal S/N
The S/N usually shows 10 to 20 when elevation angle is above 10 degrees.

Elevation angle of satellite
The angle of satellite from horizon

Azimuth angle of satellite
The angle of satellite from true north (0 degree)

Number of available satellites
The number of satellites currently available for signal reception

Total number of satellites
The total number of satellites currently in service

Selecting a measuring system mode

Initial setup: 3D

If altitude is not required such as a ship on the sea, use the 2D (two-dimensional measurement) mode to keep low DOP value. Low DOP equals greater accuracy. If you cannot receive signals from four satellites or if the PDOP value exceeds the limit, the 3D (three-dimensional measurement) mode is automatically switched to the 2D mode.

Initial setup: 3D

Selecting a geodetic datum

Initial setup: WGS-84

The latitude and longitude are calculated based on the WGS-84 with GPS system. However, the charts used in many countries are based on different geodetic datums. You can compensate this difference from your chart by converting GPS position data into your actual chart system. To select a geodetic datum, see "Local Geodetic System" (page 74).

Setting antenna height (above sea level)

Initial height: 0

In case of 2D mode, the antenna height from sea level must be entered within 5 meters or 16 3/8 feet in accuracy. If failed, the positioning accuracy may be worsened. The data can be set in either metric or imperial system. For detail, refer to the setting procedure "Menu 8, Changing the antenna height", on page 60 in this manual.

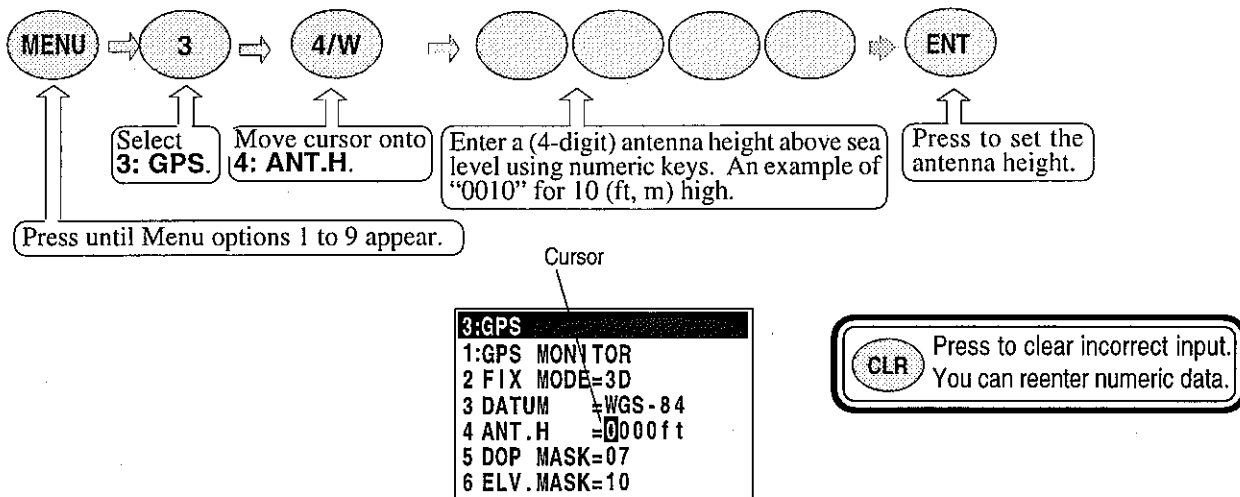

Masking DOP

Initial setup: 07

You can set a DOP mask value in two-dimensional positioning to minimize the position fluctuation. When the HDOP value exceeds this limit, positioning is stopped. During three-dimensional positioning, you can set a PDOP mask value. When a satellite combination exceeds this limit, two-dimensional positioning is selected automatically.

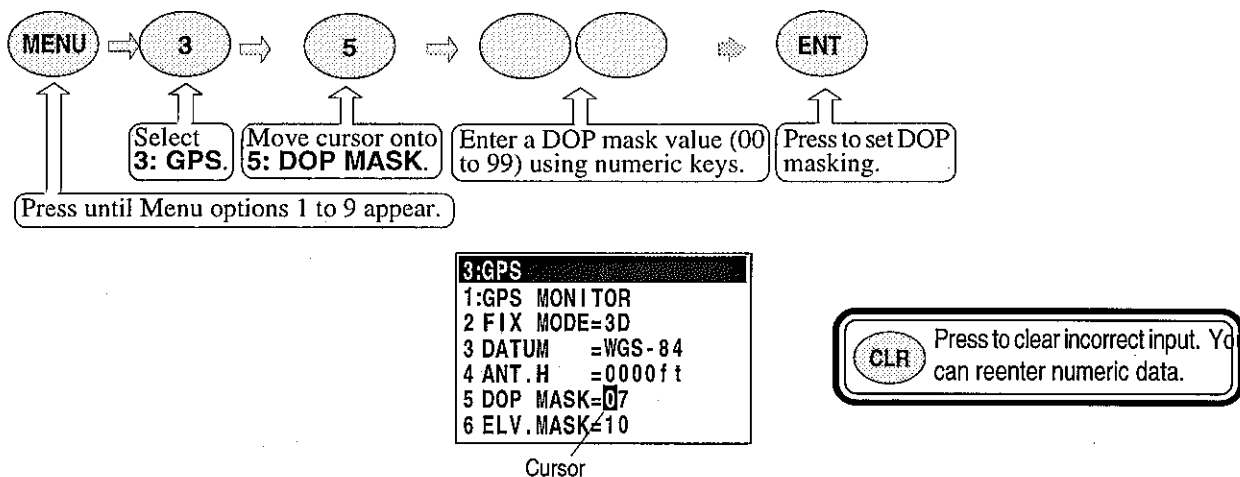

Masking satellite elevation angle

Initial setup: 10 degrees

When the satellite is below 5 degrees above the horizon, signal reflection and interference can cause erroneous positioning. You can improve the positioning accuracy by masking the elevation angle. However, a large mask value shortens the signal receive time and most satellite combinations are rejected.

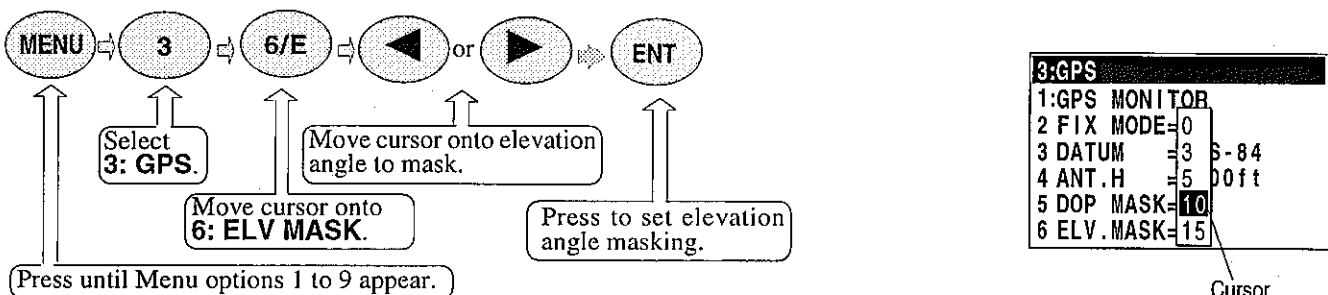

Menu 4: GPS NAVIGATOR

MODE: Return to MODE display.

What is the differential GPS (DGPS)?

This DGPS system can improve the GPS positioning accuracy, but only near the coast. DGPS positioning requires an optional differential beacon receiver, connected to a GPS navigator.

The on-shore reference station (existing radio beacon station) receives the position data (measured by the GPS). The station has also its known position data. The reference station calculates the measuring error based on these data, and generates the correction data. The station sends the correction data (RTCM SC-104) using beacon transmitter, and your NAVIGATOR receives it using beacon receiver. The NAVIGATOR can eliminate the positioning error and can improve the positioning accuracy. This accuracy is high when you are close to the reference station. Generally, the DGPS system can be used within 100 to 200 nautical miles from the reference station. (RTCM: Radio Technical Commission for Maritime Service)

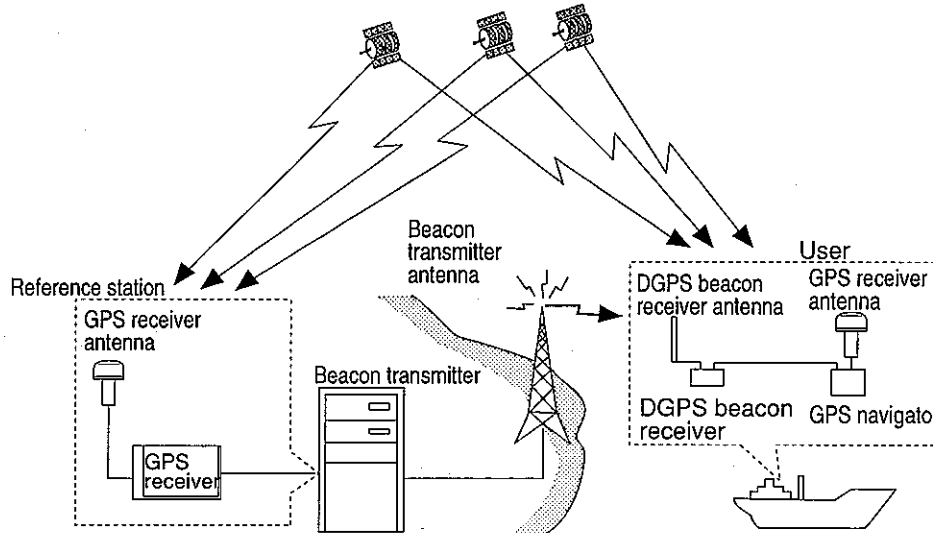

Displaying differential GPS (DGPS)

When the DGPS is set, the DGPS positioning status is displayed with letters **D** on **A** (NAV1), **B** (NAV2), **C** (NAV3), **D** (PLOT) screen.

DGPS mode indication

On: DGPS positioning in progress
 Blinks: Unsuccessful DGPS positioning
 Off: Canceled DGPS positioning

A (NAV1) screen

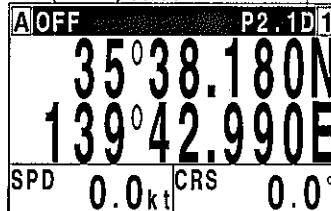

B (NAV2) screen

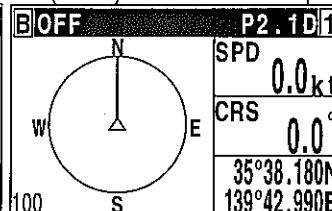

C (NAV3) screen

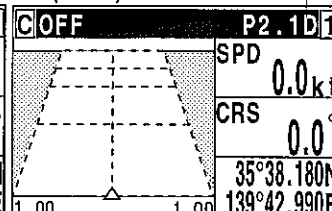

D (PLOT) screen

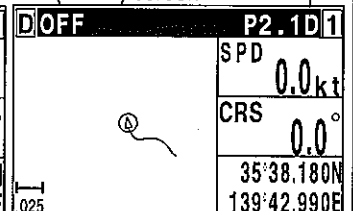

DGPS measurement

OFF: Normal GPS positioning takes place. D letter is not shown.

ON: DGPS correction takes place only. D letter continues during DGPS correction.

AUTO: DGPS correction takes place when DGPS correction data is received.

When no data is received, the normal GPS positioning is automatically changing from DGPS positioning.

Initial setup: OFF

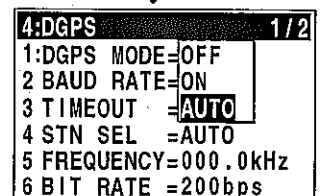
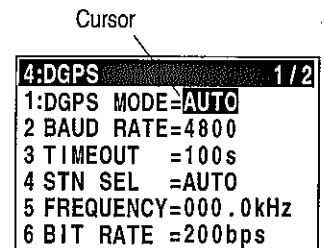
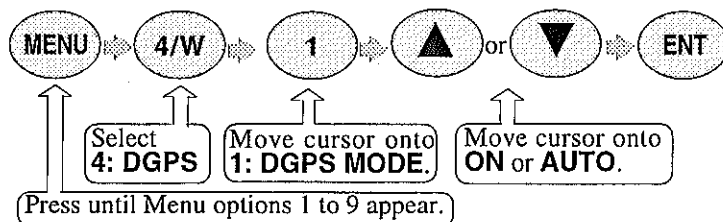

Selecting the DGPS input signal baud rate

Initial setup: 4800 bps Cursor

Adjust the baud rate of RTCM SC-104 format signal reception to the output signal baud rate of beacon receiver.

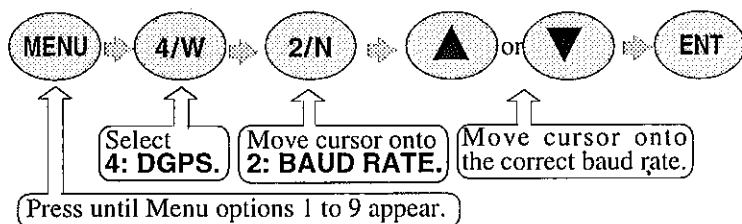

```

4:DGPS 1/2
1:DGPS MODE= AUTO
2 BAUD RATE=4800
3 TIMEOUT =100s
4 STN SEL =AUTO
5 FREQUENCY=000.0kHz
6 BIT RATE =200bps
    
```

```

4:DGPS 1/2
1:DGPS MODE= AUTO
2 BAUD RATE=2400
3 TIMEOUT =4800
4 STN SEL =9600
5 FREQUENCY=000.0kHz
6 BIT RATE =200bps
    
```

Setting a DGPS timeout

Initial time: 100 sec

If the correction data from beacon receiver is interrupted or has errors, NAVIGATOR holds the last differential correction for the duration of timeout. You can set TIMEOUT to 010 to 180 seconds. However, the position accuracy degrades as TIMEOUT lengthens.

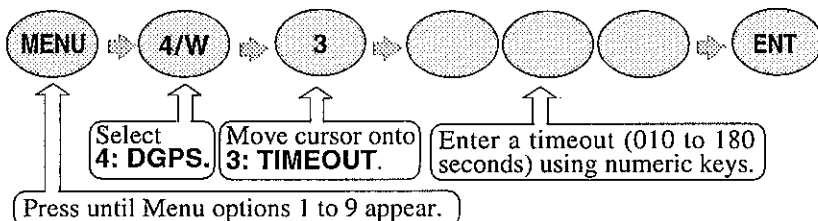

```

4:DGPS 1/2
1:DGPS MODE= AUTO
2 BAUD RATE=4800
3 TIMEOUT =100s
4 STN SEL =AUTO
5 FREQUENCY=000.0kHz
6 BIT RATE =200bps
    
```

Selecting a beacon station

Initial timesetup: AUTO

A beacon station is selectable in both the manual or auto mode.

Selecting a station in the auto mode

In the auto mode, the nearest station will be selected based on actual longitude and latitude among all the stored beacon stations.

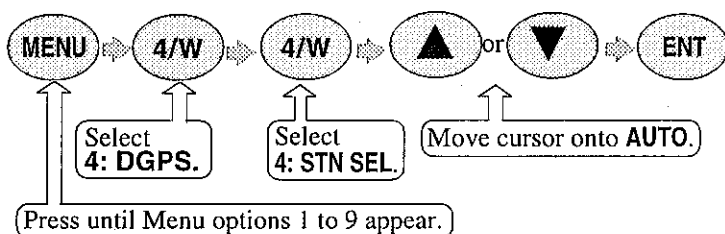

```

MENU
1:WAYPOINT 6:ALARM
2:ROUTE 7:CALCLATE
3:GPS/ 8:INIT. SET
4:DGPS 9:INTERFACE
5:COMP
    
```

```

4:DGPS 1/2
1:DGPS MODE= AUTO
2 BAUD RATE=4800
3 TIMEOUT =100s
4 STN SEL =MANUAL
5 FREQUENCY=000.0kHz
6 BIT RATE =200bps
    
```

```

4:DGPS 1/2
1:DGPS MODE= AUTO
2 BAUD RATE=4800
3 TIMEOUT =100s
4 STN SEL =AUTO
5 FREQUENCY=MANUAL
6 BIT RATE =200bps
    
```

```

4:DGPS 1/2
1:DGPS MODE= AUTO
2 BAUD RATE=4800
3 TIMEOUT =100s
4 STN SEL =AUTO
5 FREQUENCY=000.0kHz
6 BIT RATE =200bps
    
```

Selecting a station in the manual mode

Frequency Initial setup: 283.5kHz
 Selectable range: 283.5 to 325.0kHz
 Bit rate Initial setup: 200bps

In the **MANUAL** mode, frequency and bit rate of the receiving beacon station must be entered.

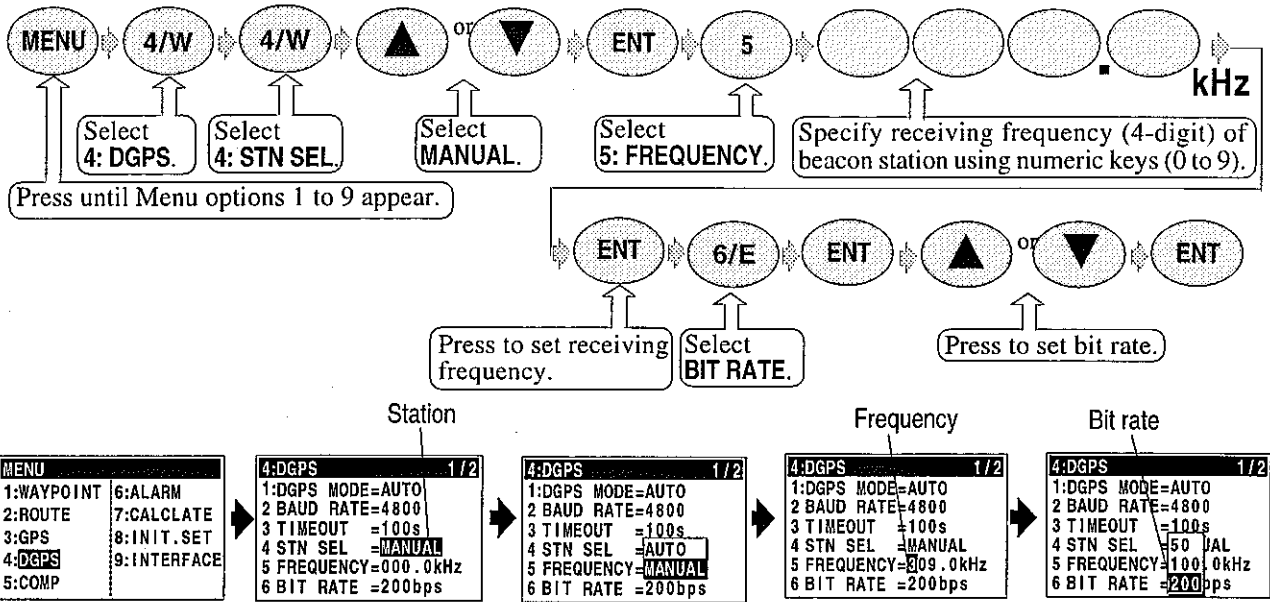

DGPS monitor

DGPS monitor provides information on the DGPS beacon receiver interface and receiving status.

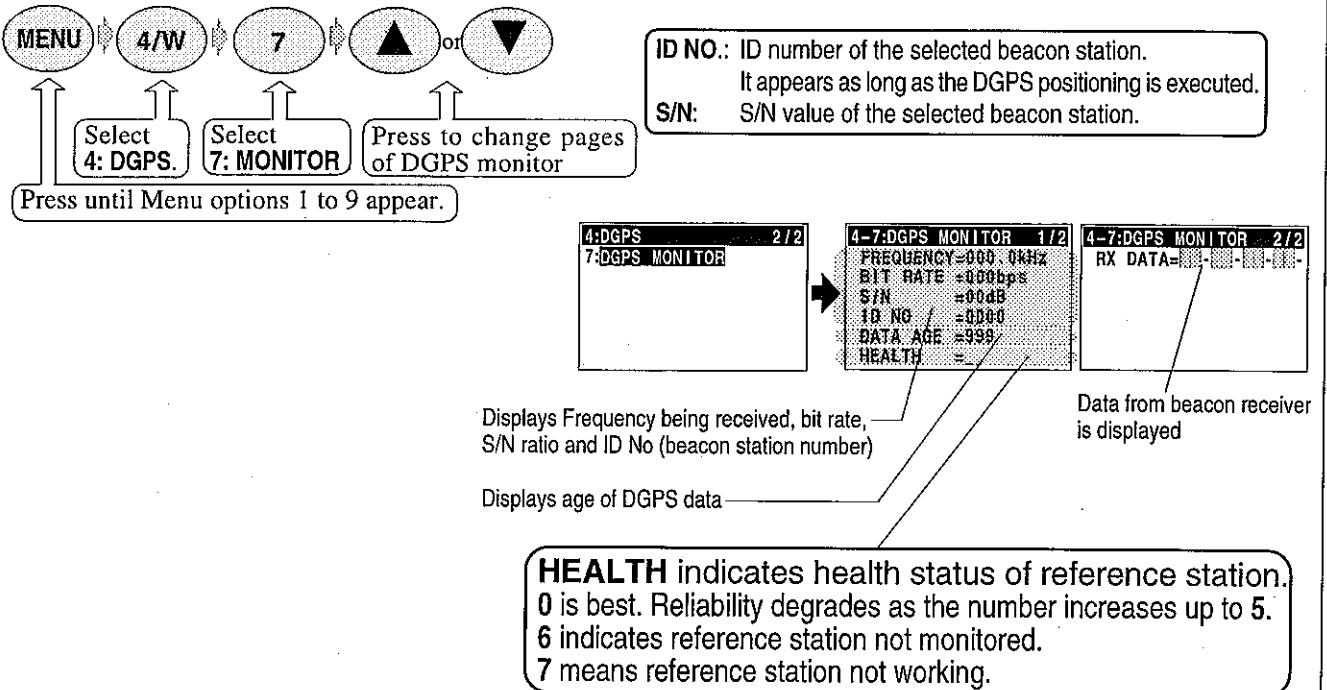

Menu 4: DGPS NAVIGATOR

MODE: Return to MODE display.

What is Differential GPS (DGPS)?

This DGPS system can improve the GPS positioning accuracy, but only near the coast.

Using DGPS requires a reference station at nearby location.

The on-shore reference station (existing radio beacon station) receives position data (measured by the GPS) and compares the known position data of the station itself, calculates the measuring error based on this data, and generates the correction information. The station sends the correction data (RTCM SC-104) using the beacon transmitter, and your NAVIGATOR receives it using the beacon receiver. The NAVIGATOR eliminates the positioning error and improves the positioning accuracy. This accuracy is high when you are close to the DGPS station. Generally, the DGPS system can be used within 100 to 200 nautical miles from the reference station. (RTCM: Radio Technical Commission for Maritime Service)

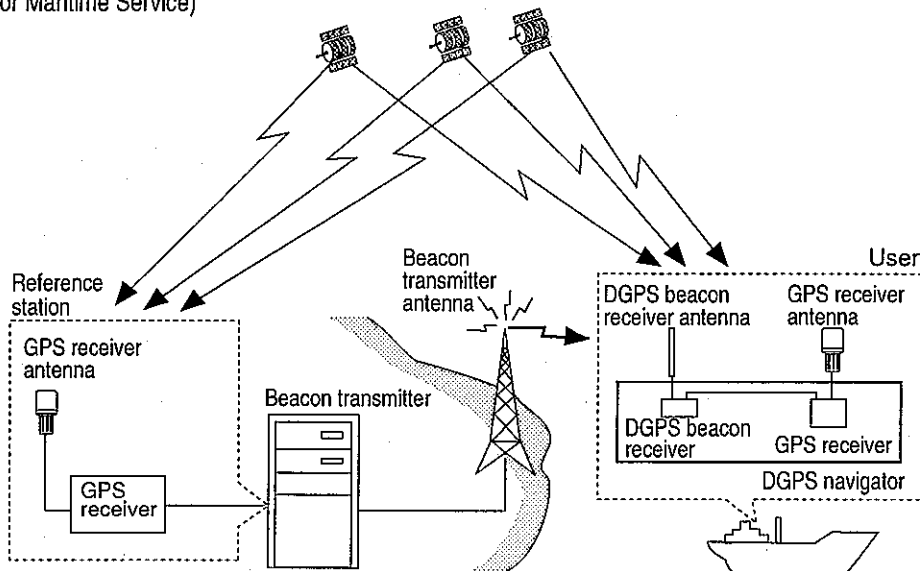

Displaying Differential GPS (DGPS)

Upon selecting the DGPS mode, the characters DGPS will appear on the A (NAV 1), B (NAV 2), C (NAV3) and D (PLOT) screens. The characters DGPS indicate that the DGPS positioning is in progress.

DGPS mode indication
 On: DGPS positioning in progress
 Blinks: Unsuccessful DGPS positioning
 Off: Canceled DGPS positioning

| A (NAV1) | B (NAV2) | C (NAV3) | D (PLOT) |
|--|---|---|---|
| A OFF P2. 1D 1 35° 38.180N 139° 42.990E SPD 0.0kt CRS 0.0° | B OFF P2. 1D 1 SPD 0.0kt CRS 0.0° 35° 38.180N 139° 42.990E | C OFF P2. 1D 1 SPD 0.0kt CRS 0.0° 35° 38.180N 139° 42.990E | D OFF P2. 1D 1 SPD 0.0kt CRS 0.0° 35° 38.180N 139° 42.990E |

DGPS measurement

OFF: Normal GPS positioning takes place. **D** letter is not shown.

ON: DGPS correction only. **D** displayed during DGPS correction.

AUTO: DGPS correction takes place when DGPS correction data is received.

When no data is received, the normal GPS positioning is automatically changing from DGPS positioning.

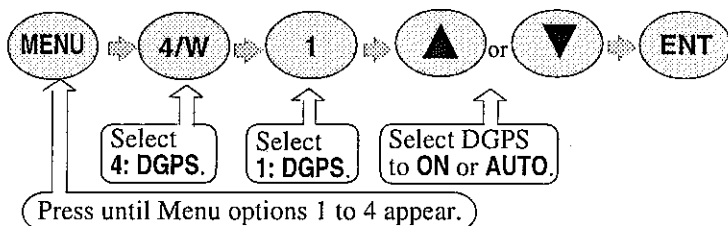

4:DGPS 1/2
 1:DGPS MODE= AUTO
 2 TIME OUT =100s
 3 STN SEN =AUTO 000
 4 FRE UENCY=000.0kHz
 5 BIT RATE =200bps
 6 STN NAME =

4:DGPS 1/2
 1:DGPS MODE=OFF
 2 BAUD RATE=ON
 3 TIMEOUT =AUTO
 4 STN SEL =AUTO
 5 FREQUENCY=000.0kHz
 6 BIT RATE =200bps

Setting a DGPS timeout

Initial timesetup: 100S (sec)

If the correction data from beacon receiver is interrupted or has error, NAVIGATOR holds the last differential correction for the duration of timeout. You can set TIMEOUT to 010 to 180 seconds. However, the position accuracy degrades as TIMEOUT lengthens.

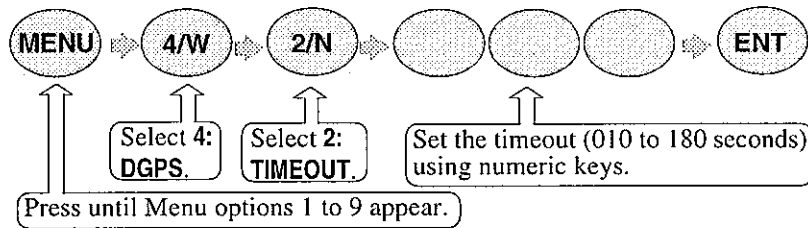

Cursor

| | |
|--------------|------------|
| 4:DGPS | 1/2 |
| 1:DGPS MODE= | AUTO |
| 2 TIME OUT = | 100s |
| 3 STN SEN = | MANUAL 000 |
| 4 FRE UENCY= | 000.0kHz |
| 5 BIT RATE = | 200bps |
| 6 STN NAME = | |

Selecting a beacon station

Initial timesetup: AUTO

A beacon station is selectable both in the manual or auto mode.

Selecting a station in the auto mode

In the auto mode, the nearest station will be selected based on measured longitude and latitude among all the stored beacon stations.

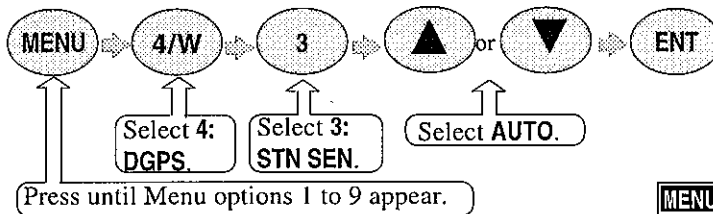

| MENU | |
|------------|-------------|
| 1:WAYPOINT | 6:ALARM |
| 2:ROUTE | 7:CALCLATE |
| 3:GPS | 8:INIT.SET |
| 4:DGPS | 9:INTERFACE |
| 5:COMP | |

Cursor

| | |
|--------------|----------|
| 4:DGPS | 1/2 |
| 1:DGPS MODE= | AUTO |
| 2 TIME OUT = | 100s |
| 3 STN SEN = | AUTO 000 |
| 4 FRE UENCY= | 000.0kHz |
| 5 BIT RATE = | 200bps |
| 6 STN NAME = | |

The number and name of a receiving station appear

Selecting a station in the manual mode

In the manual mode, specify the station number between 001 and 480.

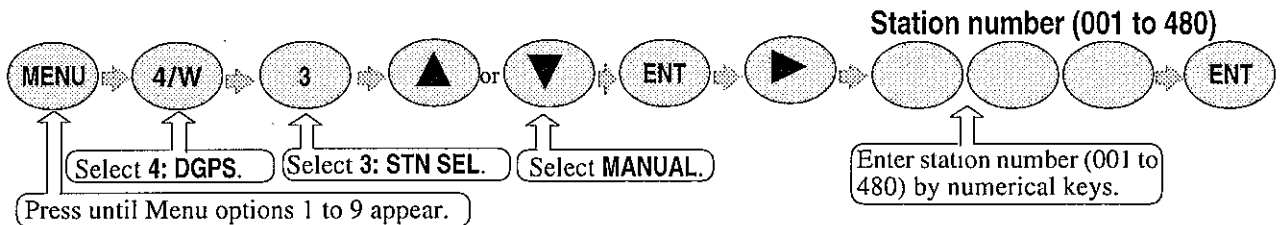

| MENU | |
|------------|-------------|
| 1:WAYPOINT | 6:ALARM |
| 2:ROUTE | 7:CALCLATE |
| 3:GPS | 8:INIT.SET |
| 4:DGPS | 9:INTERFACE |
| 5:COMP | |

| | |
|--------------|-----------|
| 4:DGPS | 1/2 |
| 1:DGPS MODE= | AUTO |
| 2 TIME OUT = | 100s |
| 3 STN SEN = | AUTO 000 |
| 4 FRE UENCY= | MANUAL Hz |
| 5 BIT RATE = | 200bps |
| 6 STN NAME = | |

| | |
|--------------|------------|
| 4:DGPS | 1/2 |
| 1:DGPS MODE= | AUTO |
| 2 TIME OUT = | 100s |
| 3 STN SEN = | MANUAL 000 |
| 4 FRE UENCY= | 000.0kHz |
| 5 BIT RATE = | 200bps |
| 6 STN NAME = | |

Description of the station number

001 - 020: Numbers which can be registered by the user.
 021 - 030: Numbers which are stored as the beacon almanac data.
 031 - 480: Numbers stored in the ROM (worldwide beacon stations are stored).

Storing a beacon station

When a beacon station is not stored or when change takes place in the data of a beacon station, reception from that station is done by registering the station data. The user can register up to 20 station numbers in the range of 001 to 020.

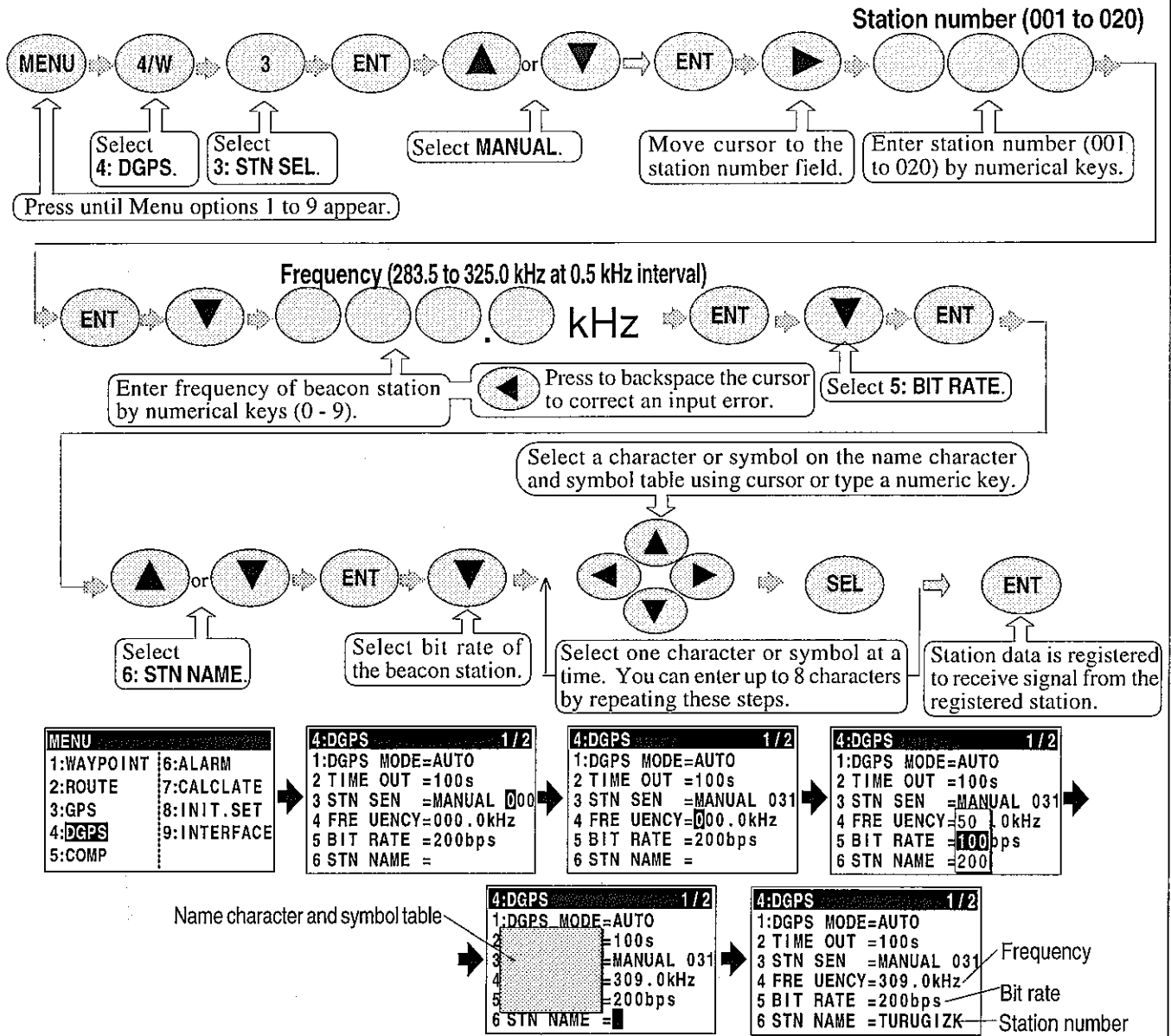

DGPS monitor

You can check the quality of the beacon reception quality in the following manner.

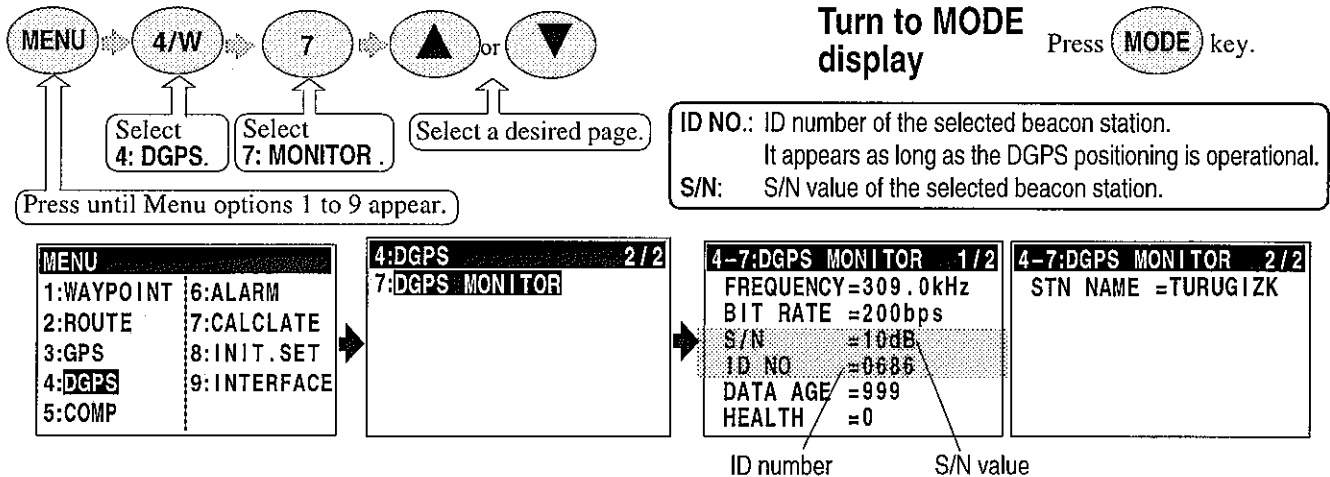

HEALTH indicates health status of reference station. 0 is best. Reliability degrades as the number increases up to 5. 6 indicates reference station not monitored. 7 means reference station not working.

Menu 5

MODE : Exit from the menu.

Correcting your position

You can compensate your GPS present position given by GPS in the following two ways:

- Enter the latitude and longitude of your actual position using numeric keys.
- Enter the correction amount to use.

Note:
The latitude and longitude correction is also available in LOPs mode.

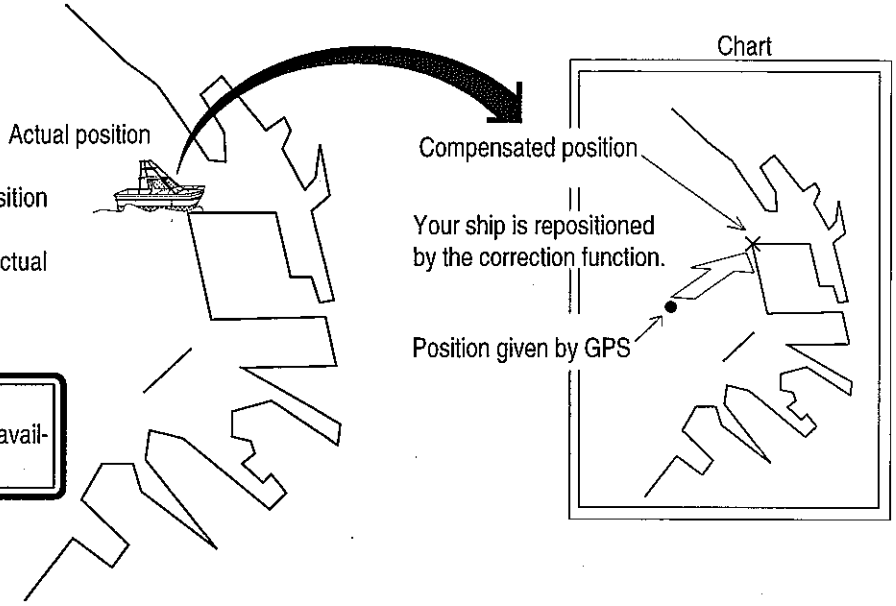

Direct entry of actual position data

Correction by LAT/LONG data entry

When your present position is displayed in LAT/LONG mode, you can correct it by entering the known LAT/LONG data.

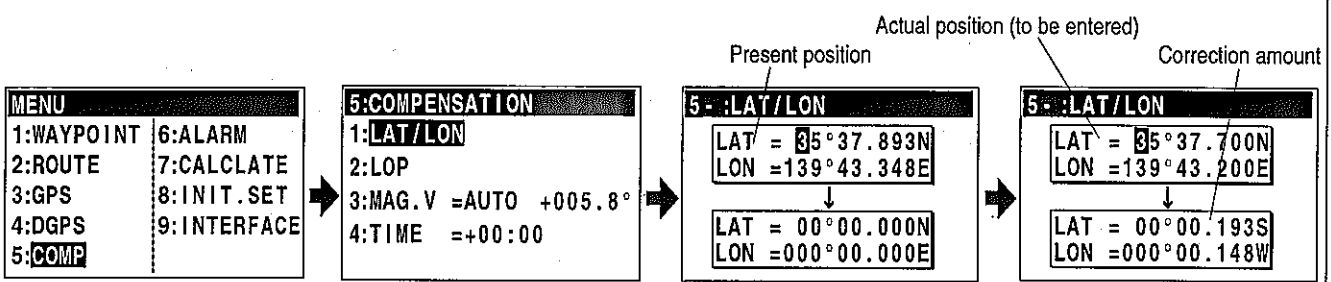
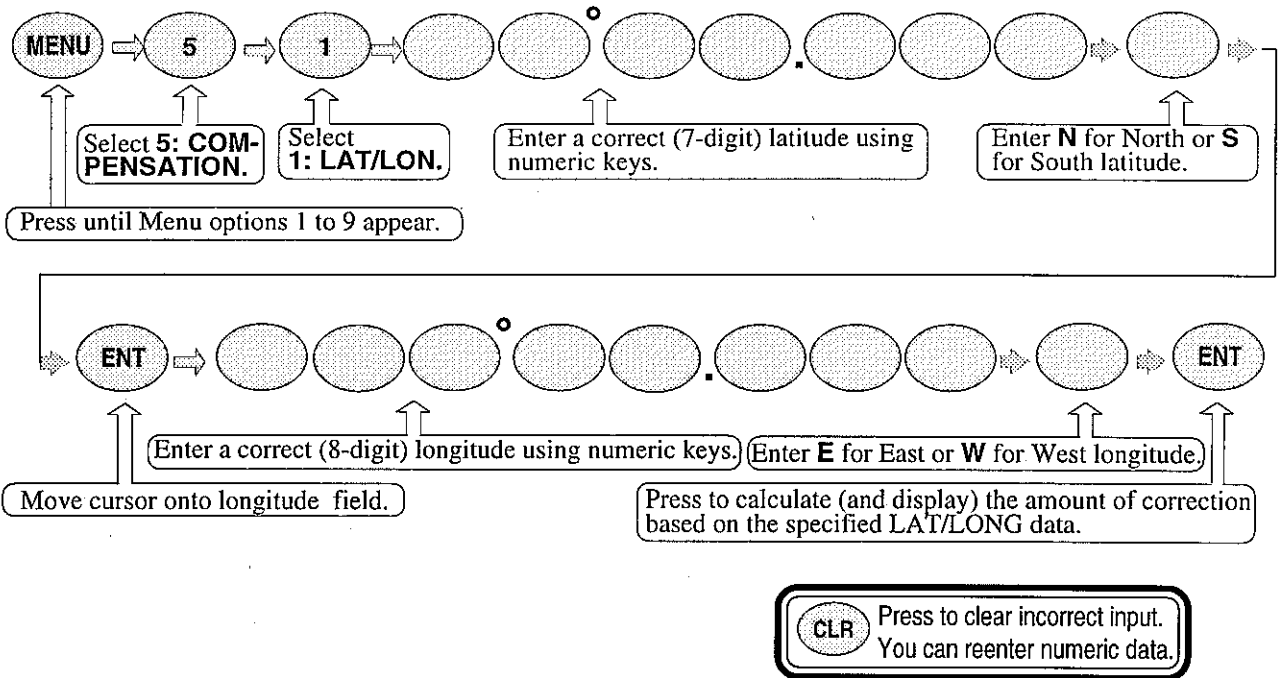

| Present position | | Actual position (to be entered) | | Correction amount | |
|------------------|---------------|---------------------------------|---------------|-------------------|-------------|
| Latitude | 35° 37.893 N | Latitude | 35° 37.700 N | Latitude | 0° 00.193 S |
| Longitude | 139° 43.348 E | Longitude | 139° 43.200 E | Longitude | 0° 00.148 W |

Entry of correction amount

Correction by LAT/LONG data entry

When your present position is shown in LAT/LONG mode, you can correct it by entering the LAT/LONG correction data.

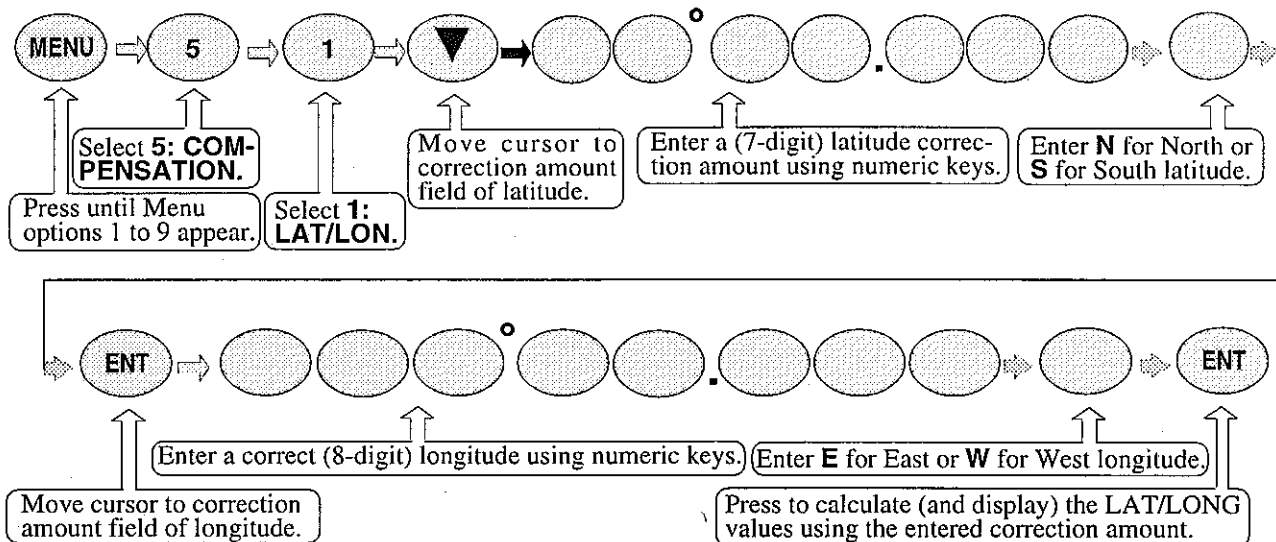

CLR

Press to clear incorrect input. You can reenter numeric data.

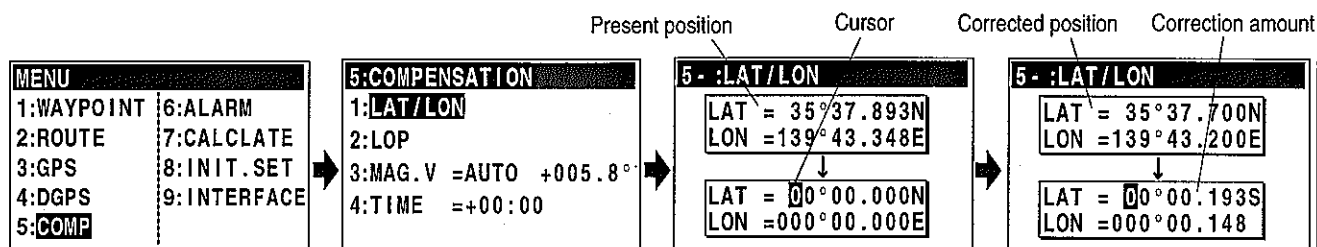

| Correction amount (to be entered) | Present position | Corrected position |
|-----------------------------------|-------------------------|-------------------------|
| Latitude 0° 00.193 S | Latitude 35° 37.893 N | Latitude 35° 37.700 N |
| Longitude 0° 00.148 W | Longitude 139° 43.348 E | Longitude 139° 43.200 E |

Checking the correction amount

You can check the correction amount as follows:

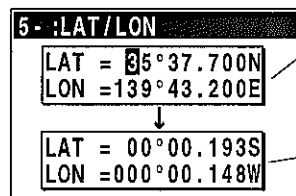
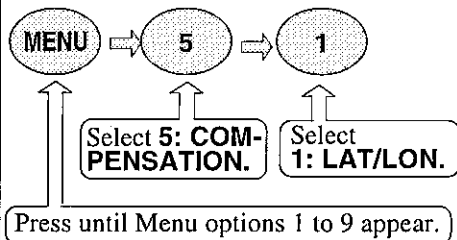

Correction data (to be entered)

The correction amount of 0.913' south and 0.148' west are shown.

Canceling position correction

You can cancel the position correction as follows:

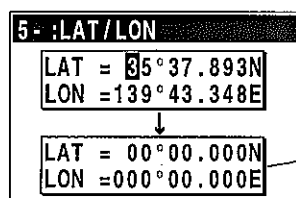
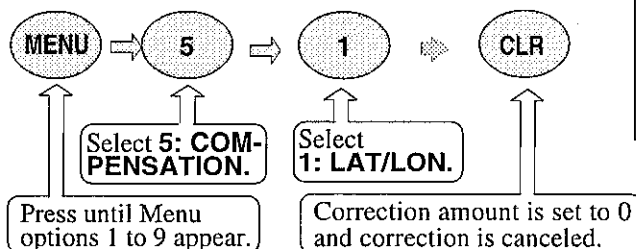

Position correction has been cleared.

Compensating the compass

The course and bearing to waypoint is shown in true bearing. You can adjust the GPS true bearing to the magnetic compass bearing.

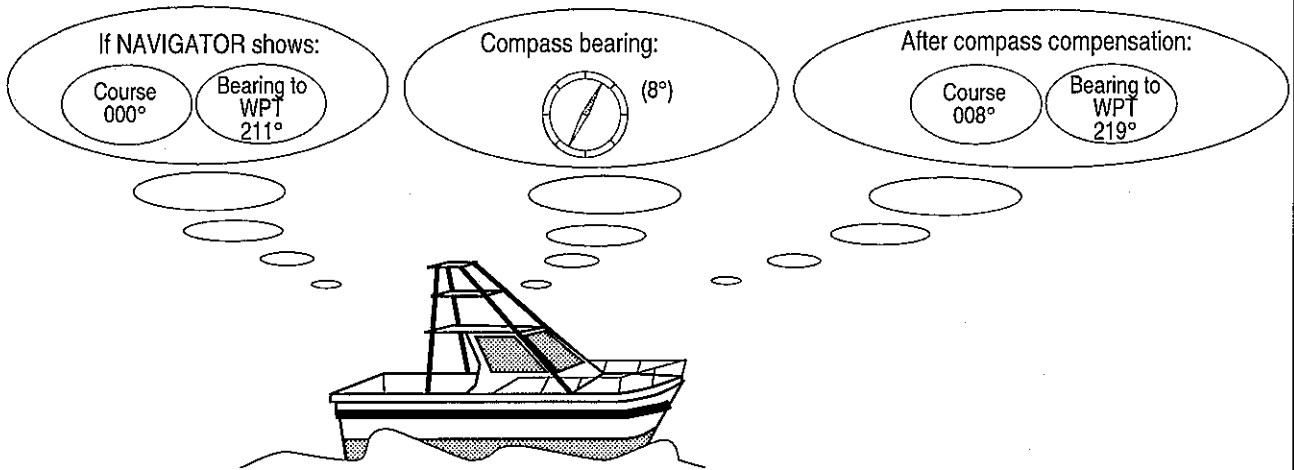

1 Automatic compensation

Initial setup: Auto mode

In the Auto mode, the magnetic compass is compensated based on the built-in global magnetic variation maps. However, avoid using this mode if you are higher than 75 degrees North or South latitude.

As the compass may have a small error because the system contains world maps. Manual correction is recommended.

For areas that do not allow exact translation of a true bearing to a magnetic bearing, despite the map covering the whole world, the resulting value may differ from the actual deviation.

```

5:COMPENSATION
1:LAT/LON
2:LOP
3:MAG.V =AUTO +005.8°
4:TIME =+00:00
    
```

An error (compensation amount) from true bearing is shown.

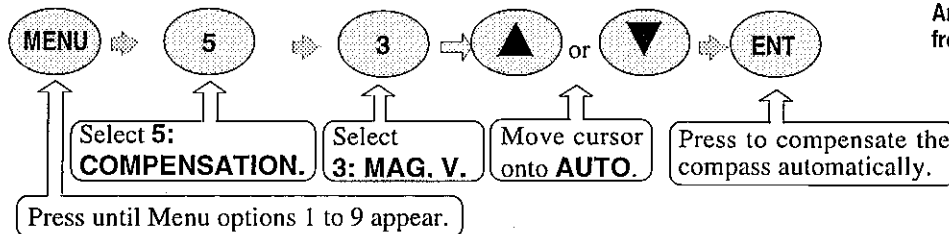

2 Manual compensation

Initial setup: 0.0°
Setup range: -180.0° to +180.0°

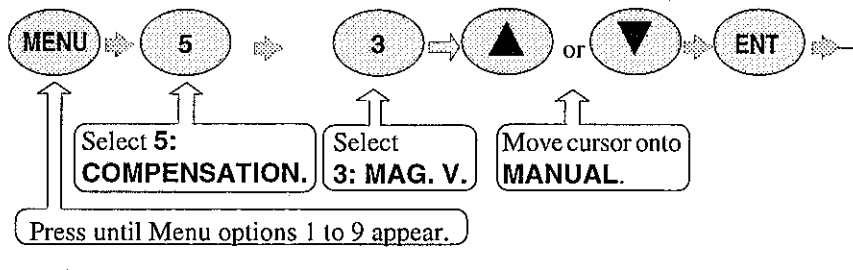

```

5:COMPENSATION
1:LAT/LON
2:LOP
3:MAG.V =MANUAL +005.8°
4:TIME =+00:00
    
```

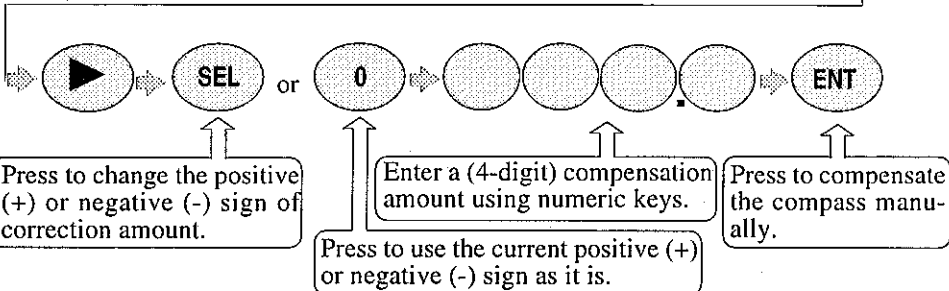

```

5:COMPENSATION
1:LAT/LON
2:LOP
3:MAG.V =MANUAL 005.8°
4:TIME =+00:00
    
```

The error (compensation amount) from true bearing is shown.

CLR Press to clear incorrect input. You can reenter numeric data.

Displaying local time

Initial setup: 00:00 hour

You can display your local time by entering a time difference from the Greenwich Mean Time (GMT). See the following chart to determine zone time difference.

Example: Japan has the time difference of +09:00 from the GMT.

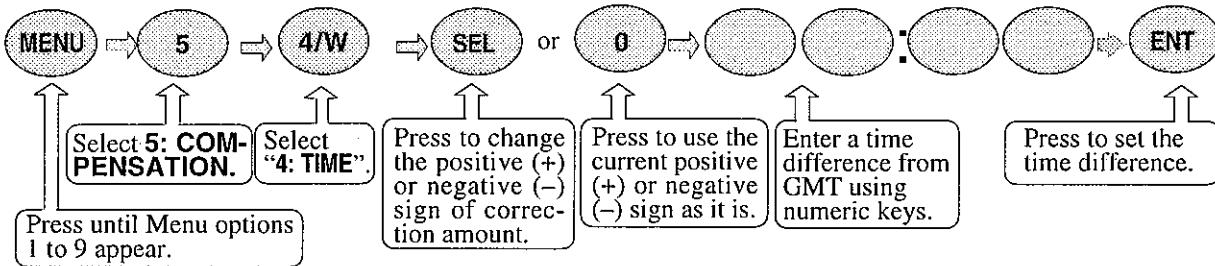

CLR Press to clear incorrect input. You can reenter a "+" or "-" sign and numeric data.

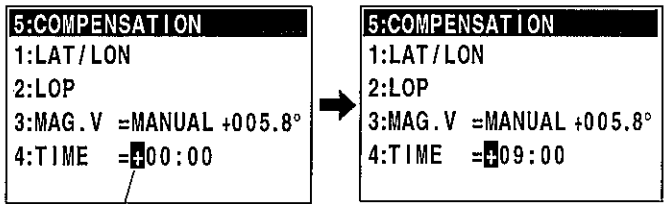

Cursor

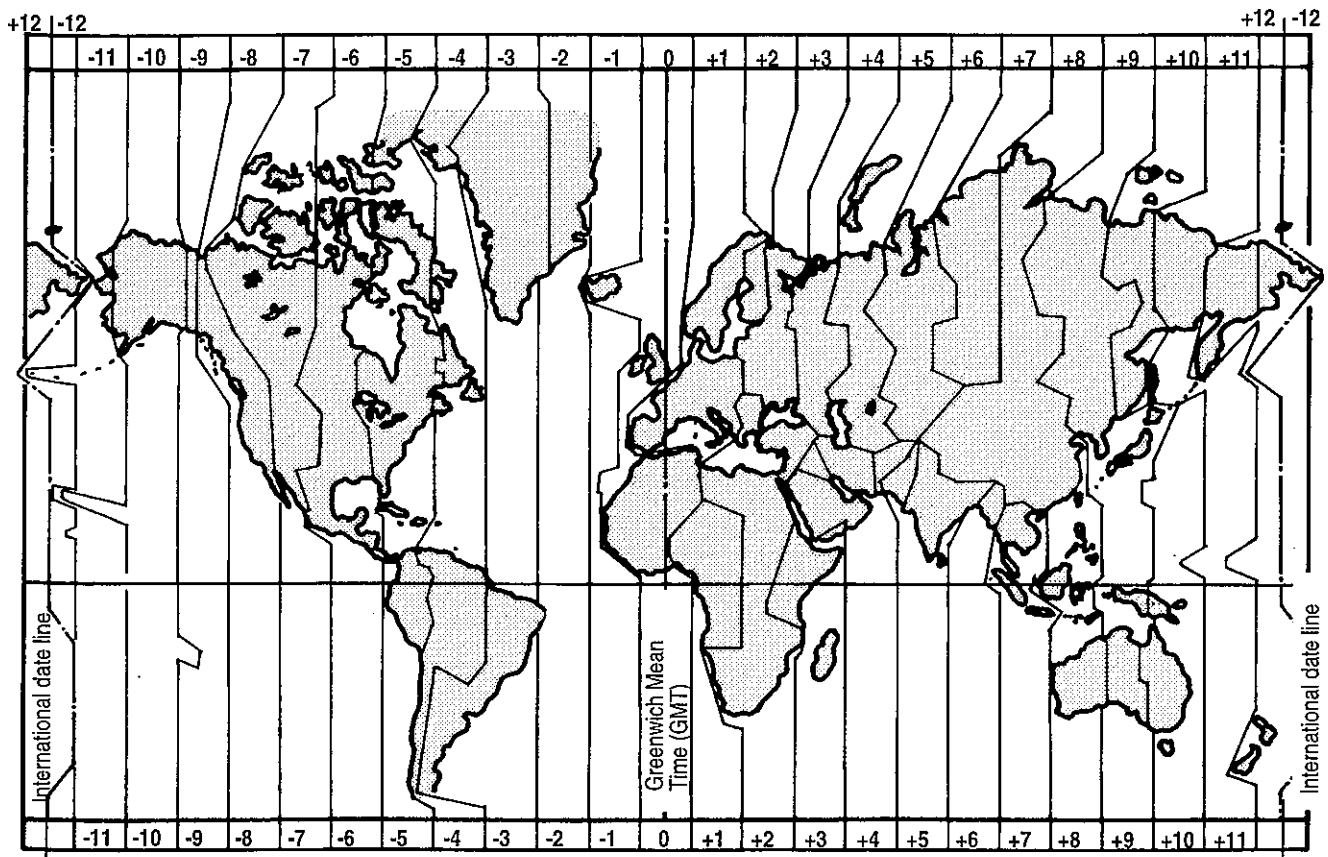

Chart

Menu 7

MODE: Return to MODE display.

Calculating the distance and bearing between two points

You can calculate the distance and bearing between two points stored in memory.

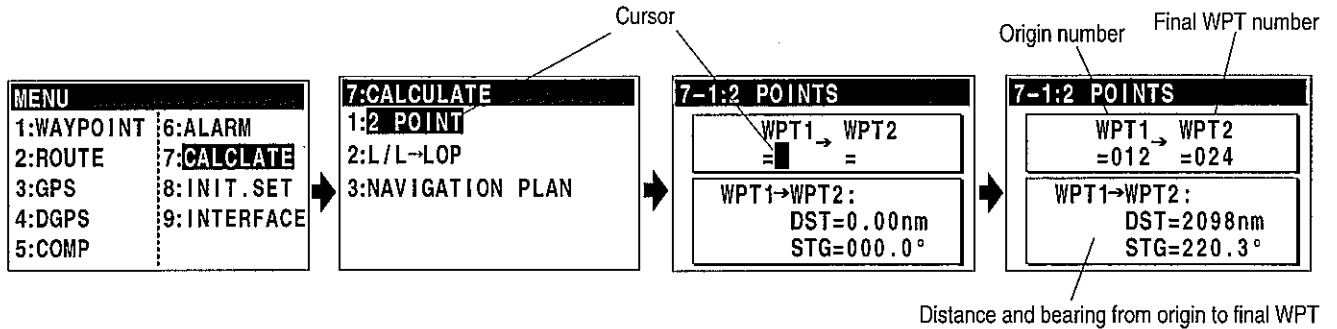
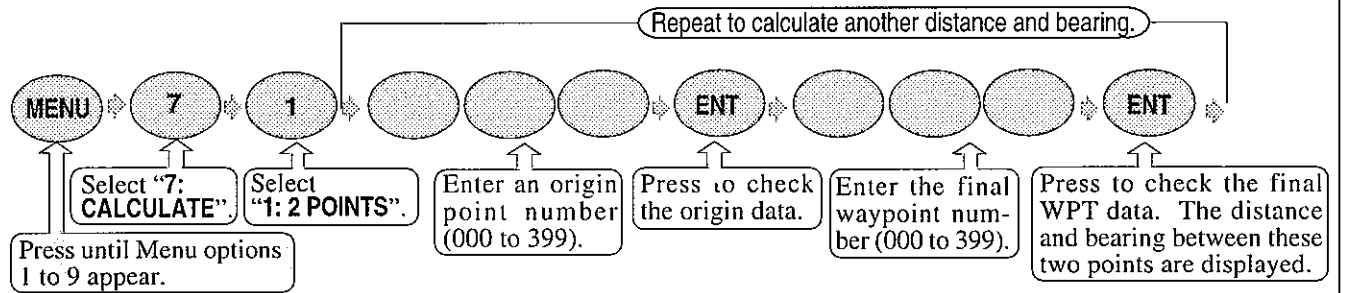

Calculating LOPs based on LAT/LONG data

For the procedure of translating LAT/LONG data into LOP (Loran C, Loran A or Decca) representation, refer to the "Menu 7: Calculating LOPs based on LAT/LONG data" (page 41 to 43).

Course calculation to a waypoint (boat speed, arrival time and time to go to waypoint)

Following operations compute the time required to a memorized waypoint from your current position and the time you arrive there as well as the required speed of your boat. Before performing this calculation, you must make sure that your current position measured with GPS or DGPS is accurate.

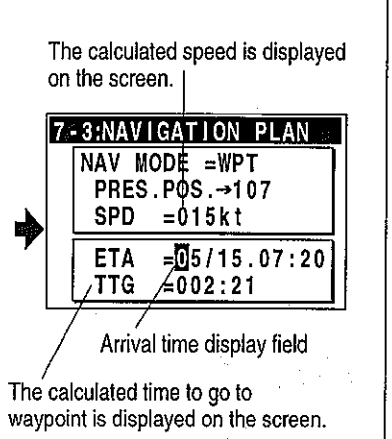
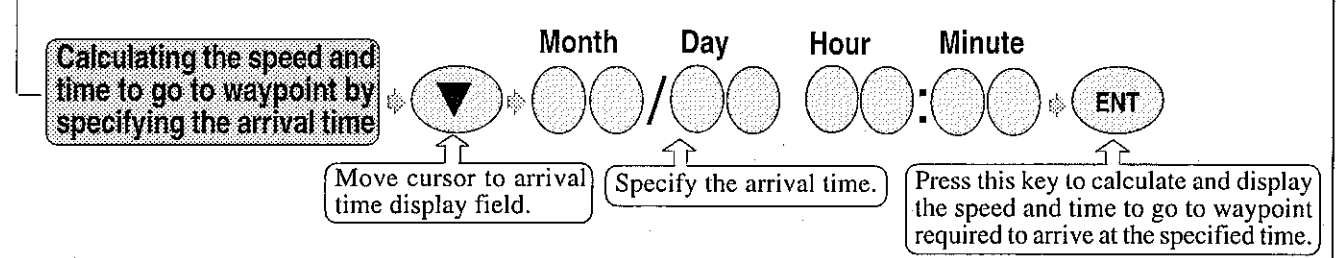
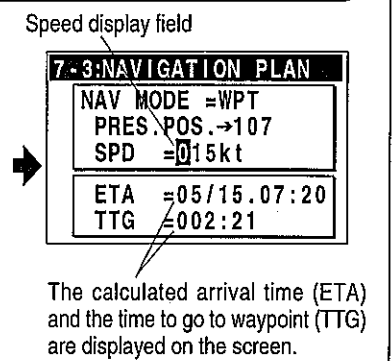
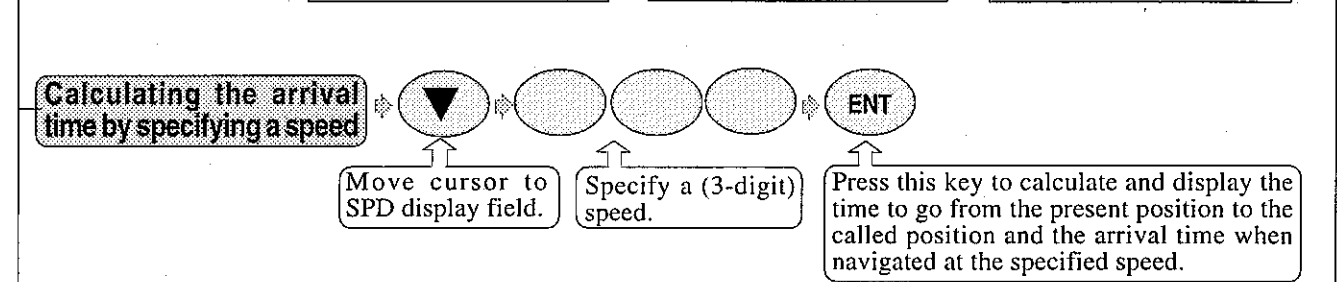
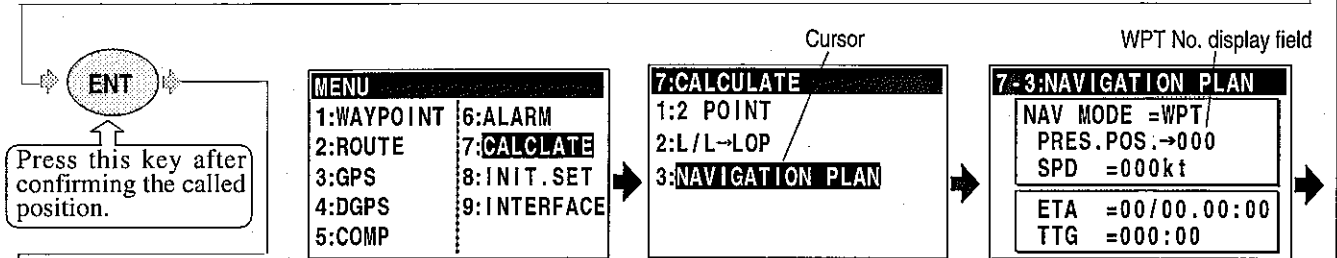
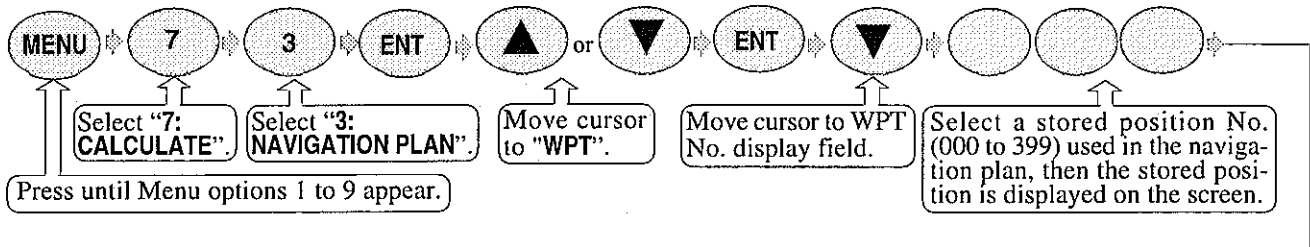

Course calculation to a destination (boat speed, final arrival time and total navigation time)

Following operations compute the time required to a memorized final destination from your current position and the time you arrive there as well as the required speed of your boat. Before performing this calculation, you must make sure that your current position measured by GPS or DGPS is accurate.

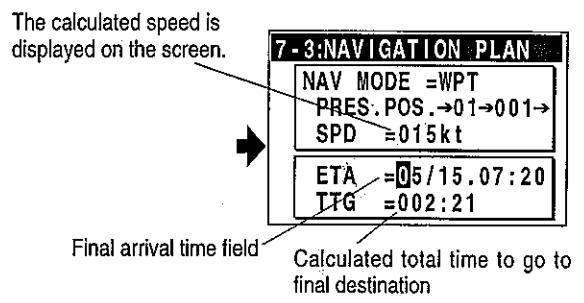
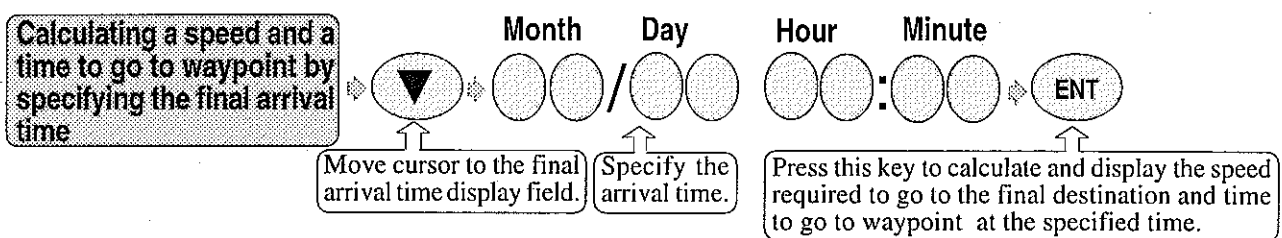
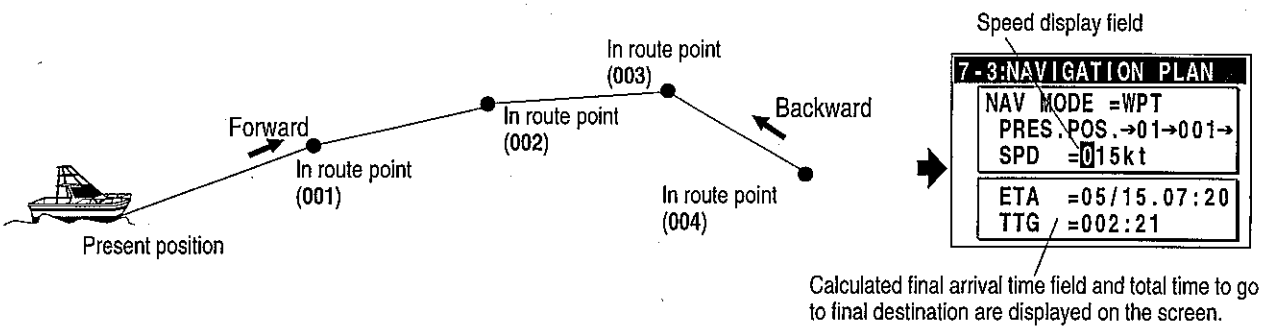
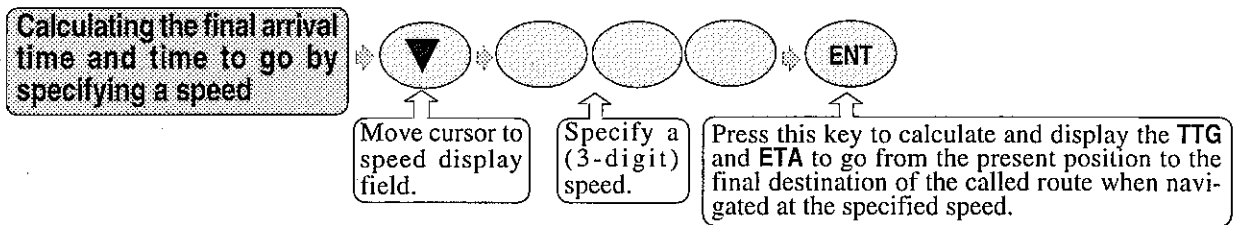
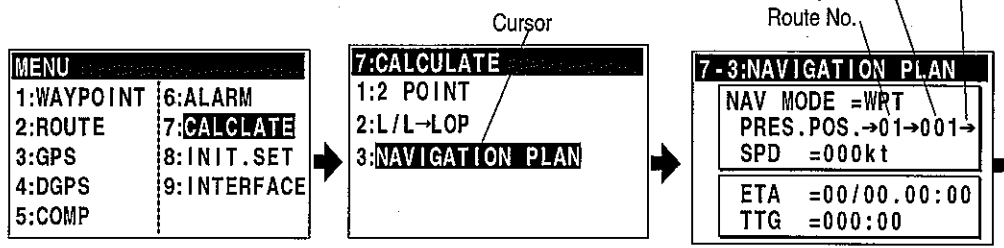
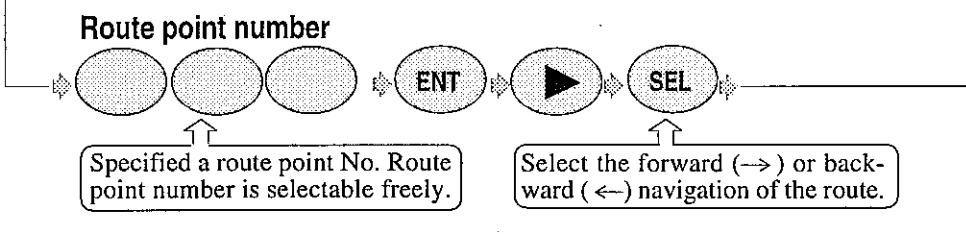
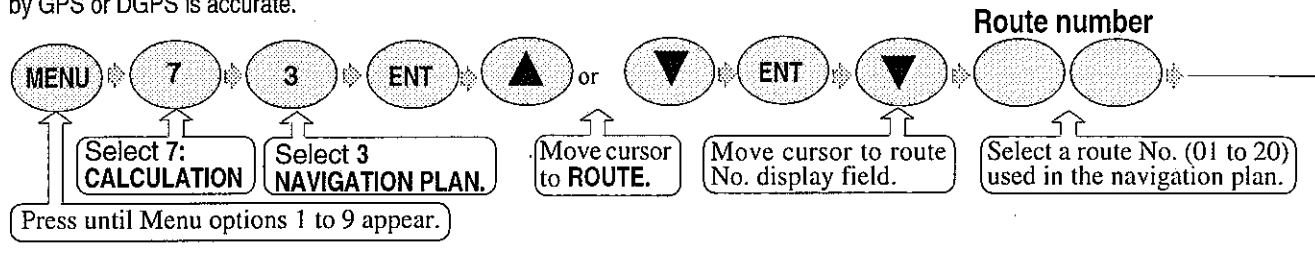

Menu 8: Initial settings

MODE: Exit from the menu.

Setting desired format.

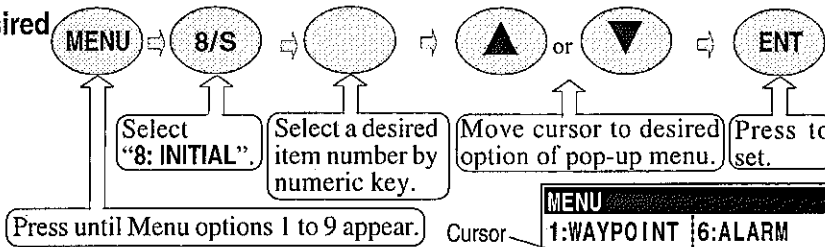

Exit from the menu.

MODE You can exit from the menu by displaying A (NAV 1), B (NAV 2), C (NAV 3) or D (PLOT) screen from the MODE key.

| MENU | |
|------------|-------------|
| 1:WAYPOINT | 6:ALARM |
| 2:ROUTE | 7:CALCLATE |
| 3:GPS | 8:INIT.SET |
| 4:DGPS | 9:INTERFACE |
| 5:COMP | |

| | |
|--------------|-----------|
| 8:INIT.SET | 1/2 |
| 1:AVERAGE = | 1 |
| 2:UNIT(DST)= | nm |
| 3:UNIT(ALT)= | ft |
| 4:SAIL MODE= | GREAT CIR |
| 5:POSITION = | L/L |
| 6:L/L UNIT = | .001 |

| | |
|------------|----------|
| 8:INIT.SET | 2/2 |
| 7:CHAIN = | 0000-0-0 |

1: Setting average constants (measuring position, speed and course)

Initial setup: 1

Use the averaging function to compare GPS sensor signals several times and get their average. This stabilizes the GPS position (latitude and longitude), speed and course data. The maximum averaging rate is 9 and the minimum averaging rate is 1. When you select a higher value, data is averaged more often and the display data has smaller variations. However, delays for updating occur. When you select a lower value, data is averaged less but the display data responds quicker. Selecting a constant (averaging constant) suitable for your boat speed will provide you with smoother data of the boat position, course and speed.

| | |
|-------------|-------|
| 1:AVERAGE = | 1/3/5 |
| | 6/9 |

2: Changing the distance or speed unit

Initial setup: nm

You can change the measuring unit of distance (to WPT or final destination) and speed.

| | |
|---------------|----|
| 2:UNIT(DST) = | nm |
| | km |
| | sm |

Unit conversion

| | | | |
|------|-------|-------|-------|
| | km | nm | sm |
| 1 km | | 0.540 | 0.621 |
| 1 nm | 1.852 | | 1.151 |
| 1 sm | 1.609 | 0.869 | |

3: Changing the antenna height unit

Initial setup: ft

You can change the measuring unit of antenna height (above sea level).

| | |
|---------------|----|
| 3:UNIT(ALT) = | ft |
| | m |

Unit conversion

| | | |
|------|--------|-------|
| | m | ft |
| 1 m | | 3.281 |
| 1 ft | 0.3048 | |

4: Changing sail mode

Initial setup: GREAT CIRCLE

You can change the navigation mode. There are two navigation modes.

Great Circle course: The shortest course on a sphere.

Rhumb Line course: Straight course on a Mercator chart.

| | |
|---------------|-----------|
| 4:SAIL MODE = | GREAT CIR |
| | MERCATOR |

5: Displaying position data in LAT/LONG mode

Initial setup: L/L mode

For the switching procedure, refer to the "Registering a Position in LOP" (page 36).

| | |
|--------------|-----|
| 5:POSITION = | L/L |
| | LOP |

6: Changing the latitude and longitudinal display digits (between .001' and .0001')

The following operations enable to display the latitude and longitude of present position up to 0.0001 minute.

Initial setup: .001'

If you select .0001', the latitude and longitude data of GGA sentence will also be output in 0.0001' in the Output Data Format 0183.

| | |
|--------------|-------|
| 6:L/L UNIT = | .001 |
| | .0001 |

Sample displays when .0001 is selected:

A (NAV1) screen

B (NAV2) screen

C (NAV3) screen

D (PLOT) screen

| | |
|--------------|----------|
| A OFF | P2.1D1 |
| 35°38.1872N | |
| 139°42.9918E | |
| SPD 0.0kt | CRS 0.0i |

| | |
|--------------|--------|
| B OFF | P2.1D1 |
| SPD 0.0kt | |
| CRS 0.0° | |
| 35°38.1872N | |
| 139°42.9918E | |

| | |
|--------------|--------|
| C OFF | P2.1D1 |
| SPD 0.0kt | |
| CRS 0.0° | |
| 35°38.1872N | |
| 139°42.9918E | |

| | |
|--------------|--------|
| D OFF | P2.1D1 |
| SPD 0.0kt | |
| CRS 0.0° | |
| 35°38.1872N | |
| 139°42.9918E | |

Present position

Present position

Present position

Present position

7: Specifying the chain and secondary stations for Loran C, Loran A or Decca

For the operating procedure, refer to the "Initial setup for LOP display" (page 34).

Menu 9

Selecting an output data format : DGPS NAVIGATOR only selectable

You can select the format of output data.

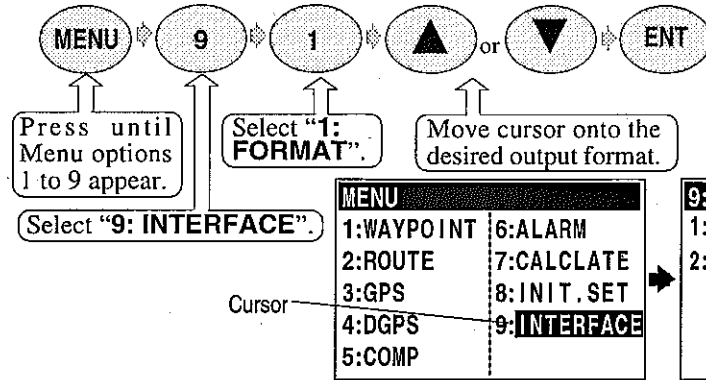

Initial setup: 0183

Output of GPS NAVIGATOR is NMEA-0183 only.

```

9:INTERFACE
1:FORMAT=0183
2:0183 EDIT
    
```

```

9:INTERFACE
1:FORMAT=0183
2:0183 EDIT
    
```

[Only 0183 usable]

Editing the NMEA-0183 output data format

Initial setup: Sentence: GLL, GGA, RMC, VTG, ZDA
Cycle: 1 second

You can select the output sentence and set the output cycle (in seconds) of the NMEA-0183 output data format.

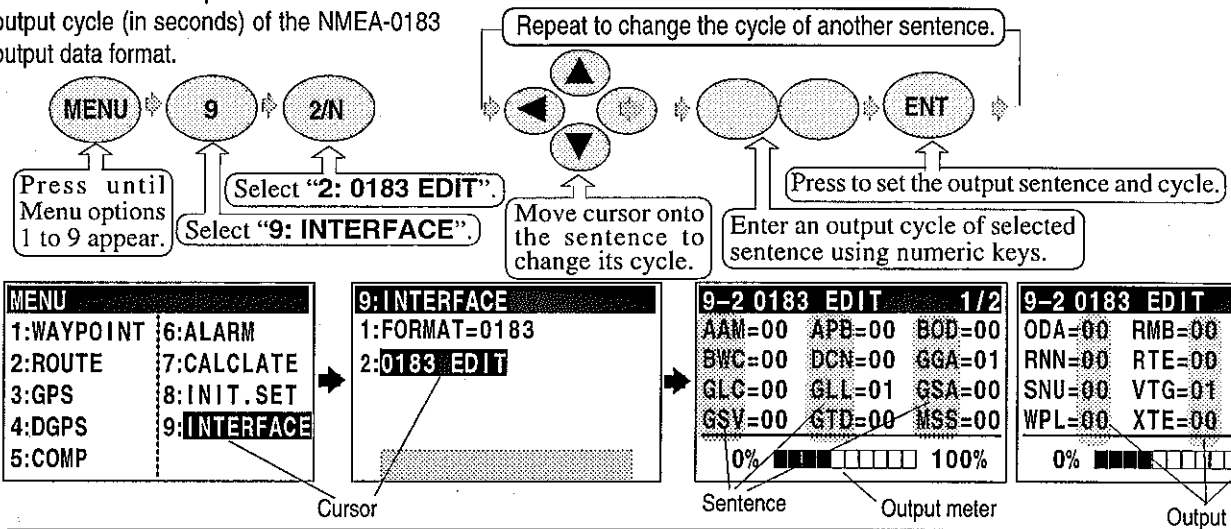

Set the output cycle for the required sentence only and set the unused data to "00". The output meter indicates the ratio of total data amount (of selected sentence) to the data transmission capacity (about 10% per scale). Do not maximize at 100% or poor performance may result.

Press CLR to clear incorrect input. You can reenter numeric data.

Explanation of output data (sentence)

| NMEA-0183 | Code | Description |
|-----------|------|--|
| | AAM | Waypoint Arrival Alarm |
| | APB | Autopilot Sentence "B" (Bearing from origin or present position to the waypoint). |
| | BOD | Bearing - Point of Origin to Destination. |
| | BWC | Bearing & Distance to Waypoint in Great Circle navigation. |
| | DCN | Decca Position |
| | GGA | Global Positioning System Fix Data (Time, Lat/long, S/N, SV, DOP) |
| | GLC | Geographic Position - Loran-C LOPs (NMEA-0183 Ver. 2.0) |
| | GLL | Geographic Position - Latitude/Longitude. |
| | GSA | GPS DOP and Active Satellites |
| | GSV | GPS Satellites in View |
| | GTD | Geographical Position - Loran-C LOPs (NMEA-0183 Ver.1.5) |
| | MSS | MSK receiver signal status (S/N, Frequency, Data rate) |
| | ODA | Satellite information (KODEN's proprietary) |
| | RMB | Recommended Minimum Navigation Information (Cross track error, Bearing to steer, Position number of point of origin, Lat/long, Bearing and distance from present position to waypoint, approaching speed to waypoint, proximity alarm) |
| | RMC | Recommended Minimum Specific GPS/TRANSIT Data (UTC time, lat/long, ground speed, true bearing, magnetic deviation, date) |
| | Rnn | Route number and waypoint number (Max. 4 points including next waypoint) |
| | RTE | Route number and waypoint number (Max. 4 points including next waypoint) |
| | SGR | Loran-C Chain Identifier |
| | SNU | GPS SNR Status |
| | VTG | Course Over Ground (true and magnetic bearing) and Ground Speed |
| | WDC | Distance to Waypoint |
| | WPL | Waypoint Location Lat/long, waypoint number |
| | XTE | Cross-Track Error, Bearing to steer |
| | ZDA | Time & Date (Hour, minute, second, day, month, year, time difference) by UTC |
| NMEA 1 | | GLL, GGA, VTG, ZDA: Fixed (1-sec cycle), NMEA-0183 (version 1.5) |
| NMEA 2 | | GLL, GGA, VTG, ZDA: Fixed (2- to 3-sec cycle), NMEA-0183 (version 1.5) |
| CIF | | LAT/LONG, speed, course, and Loran C LOPs (Furuno's format) |
| SHIP | | LAT/LONG data (SHIPMATE 0183) |
| RTCM | | DGPS correction data |

Outputting waypoint data during route navigation

Initial setup : NEXT

When selecting the output of waypoint data (in Rnn and WPL sentences) as route navigation is turned on, you can specify which waypoint data is to be output first.

Selecting an output format of waypoint data

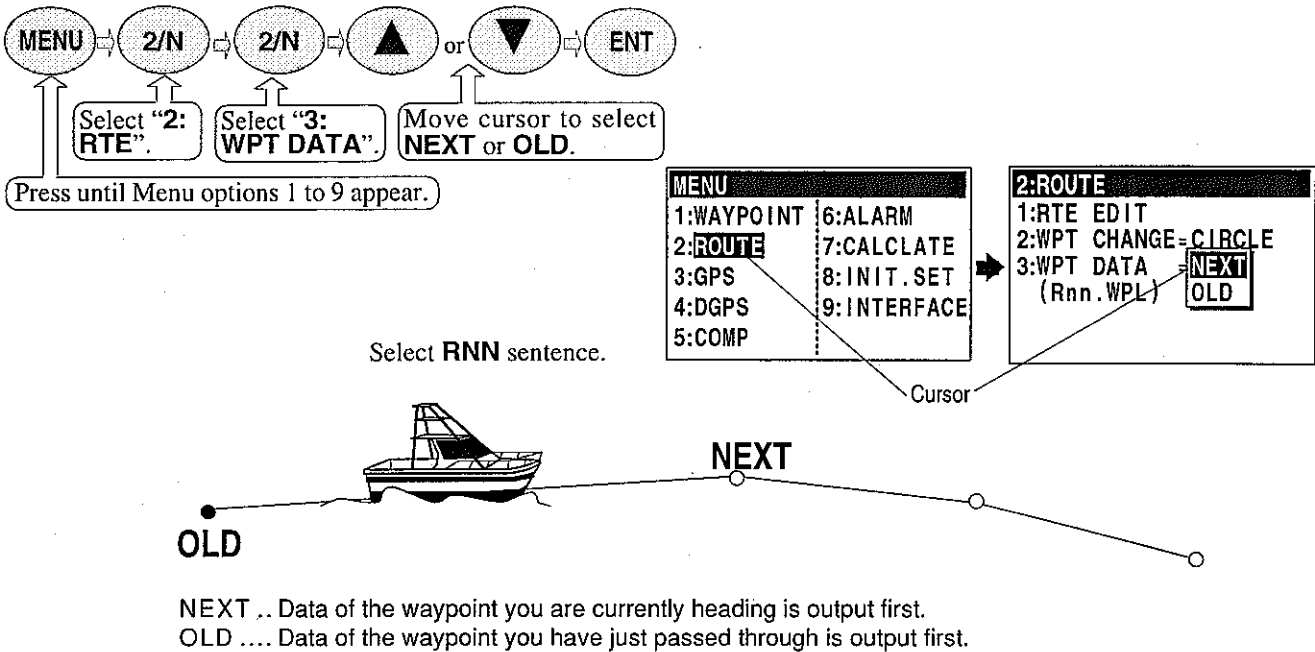

Selecting an output cycle of waypoint data (in Rnn and WPL)

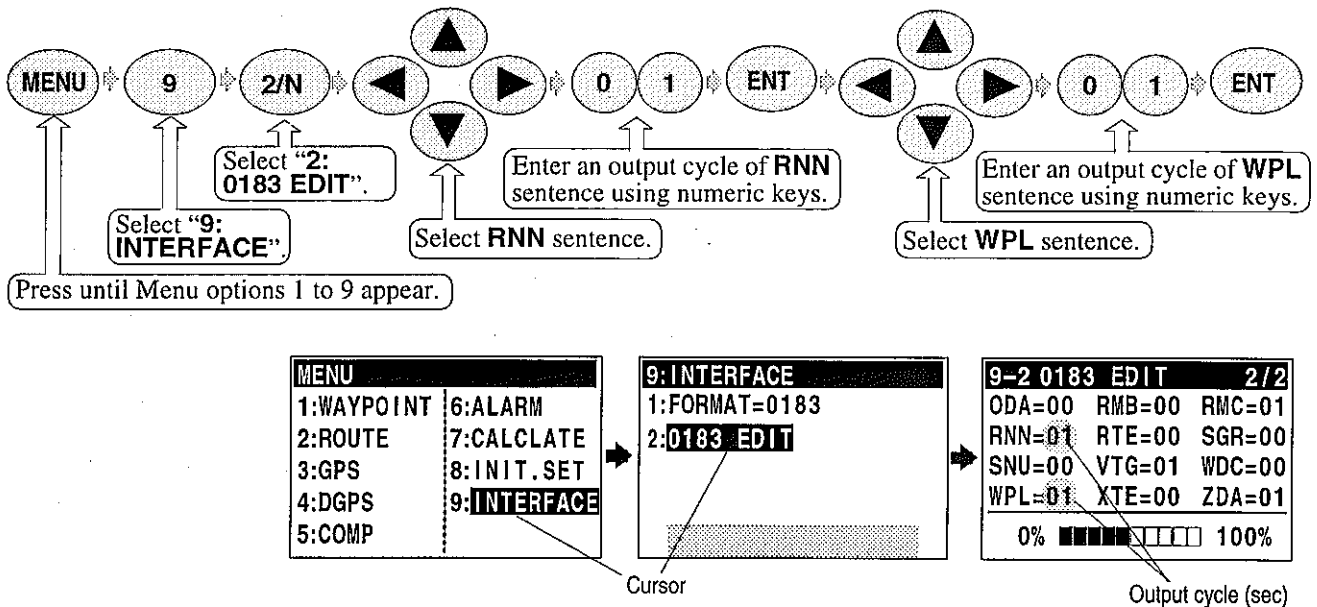

Operation of built-in simulator

The built-in simulator helps you practice operation before you use it in the field. Only a power source is required to turn on the unit. You enter the starting position of the simulated navigation at point number 399 in LAT/LONG referring to "Storing Waypoints" (page 13). Then, turn the unit off. Restart the unit by pressing PWR/DIM key and press "4" key when a text "CHECK OK" is displayed on the screen. When a beep sounds, the settings for the simulated navigation will complete.

Your position draws a circle from the position in point number 399 at 10.0 kt speed with 0.1 nm radius. It takes about 3 minutes 40 seconds for each circle. Select the 0.025-nm or 0.05-nm range on the PLOT screen.

You can try each function of the unit as if in practical operation. A power source is required for simulation but the antenna connection is not required. Simply turn the power off to get back to normal operation.

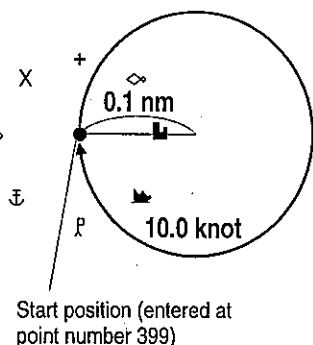

Initial Menu

Displaying the menu. Turn power on, then press the **ENT** key while the screen message "CHECKING" or "CHECK OK" is displayed.
 Note: When powered, turn the power switch off first, then proceed to the following steps.

How to use menus

Initialization

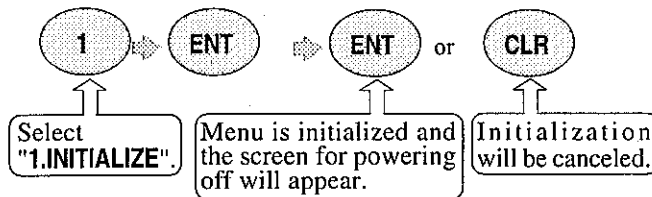

Other menu

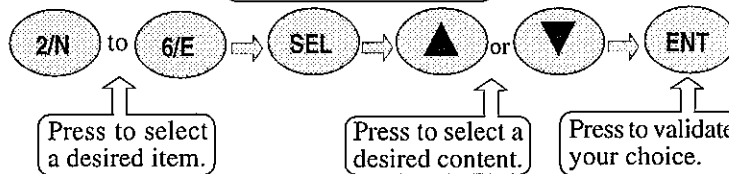

Exit from the menu

Press the **MODE** key to display the screen for powering off.

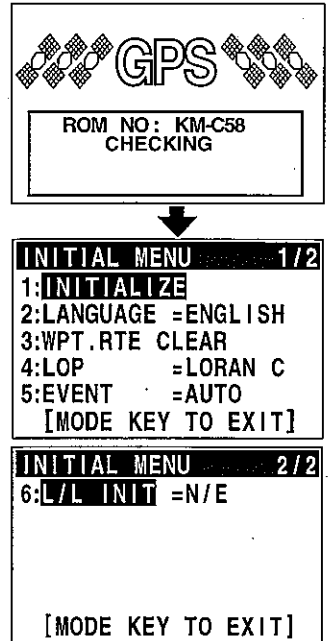

1: Initialization

If your GPS position has failed due to satellite maintenance or other reason, initialize your GPS navigator. Then, set all system parameters again.

DELETE?
YES=ENT
NO =CLR

2: Changing the display language

Initial setup: ENGLISH

You can change the display language.

Already registered data on the waypoints, events, MOB's and routes remain unchanged.

ENGLISH
ニホンコ
中文

3: Erasing entire data from memory

You can erase the entire data such as waypoints, events, MOB, and route from memory.

DELETE?
YES=ENT
NO =CLR

4: Switching between Loran C LOPs, Loran A LOPs and Decca LOPs

Initial setup: LORAN C

This menu option allows you to select a desired display among the loran C LOP, Loran A LOP and Decca LOP.

Already registered data on the waypoints, events, MOB's and routes remain unchanged.

LORAN C
LORAN A
DECCA

5: Changing a storing method for present position (EVENT)

Initial setup: AUTO

You can use either of the following two procedures for registering your current position (event).

In the **MANUAL** mode, you can specify desired registration numbers.

AUTO Pressing the **EVT** key automatically registers the points starting from No. 001 through 199. When the 200th point is reached, the number is returned to 001 again and the older data is sequentially replaced by the newer one.

MANUAL Press the **EVT** key, then specify desired registration numbers (in the range of 001 to 199) from the numerical keypad.

EVT=001
+ 15 04:59
35° 38.180N
139° 42.990E

AUTO
MANUAL

6: Selecting an initial value (North, South, East, West) of latitude/longitude

Initial setup: N/W

N/W (N. Lat./W. Long.) .. When power is turned on, GPS or DGPS position measurement is started using the north latitude/west longitude region as the initial value.

N/E (N. Lat./E. Long.) When power is turned on, GPS or DGPS position measurement is started using the north latitude/east longitude region as the initial value.

S/W (S. Lat./W. Long.) .. When power is turned on, GPS or DGPS position measurement is started using the south latitude/west longitude region as the initial value.

S/E (S. Lat./E. Long.) When power is turned on, GPS or DGPS position measurement is started using the south latitude/west longitude region as the initial value.

N/W
N/E
S/W
S/E

Troubleshooting Guide

If NAVIGATOR does not function properly, check the following points. If the problem continues, call for service.



Never attempt to open the cabinet.

Nothing appears when you press PWR/DIM key

Check the following points:

- Blown fuse
- Low battery voltage
- Poor contact of power cable to battery socket
- Poor contact of power cable to display unit



Caution

Always turn Off power supply before replacing the fuse.

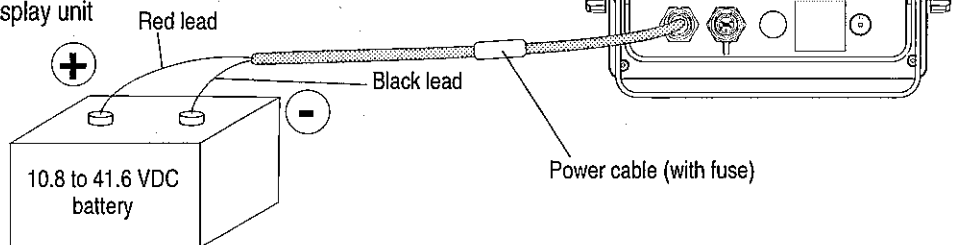

The display does not change (during reset)

Check the following points:

- If GPS signals are not received or key operation is not effective, try the following steps:

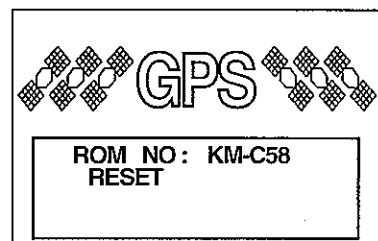
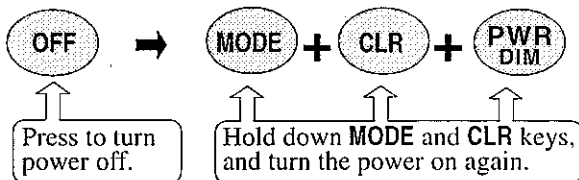

The stored position data is NOT lost even when you perform these steps.

The present positioning data is erased and NAVIGATOR returns to the initial setup.

All setup parameters are reset to factory defaults and you need to set them again.

Error message appears as you power on

An error message may appear when you power on.

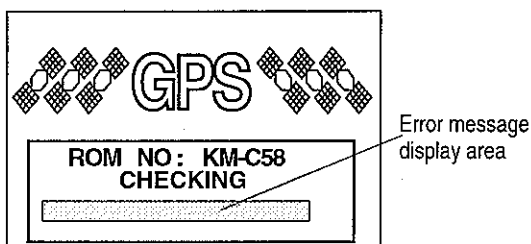

Error message display area

Error messages

- BACKUP ERROR** An error has occurred in backup RAM.
- ROM CHANGED** A checksum error has occurred.
- ROM ERROR** A ROM error has occurred.
- RAM ERROR** A RAM error has occurred.
- NO BEACON** A beacon signal entry error has occurred.
- BEACON ERROR** A connection failure with beacon has occurred.

The **ROM CHANGED** message appears when ROM has been replaced. In this case, turn the power off, then restart again.

Nothing appears but buzzer sounds during power-on

- The receiver CPU has failed.
- Call for service.

If differential GPS (DGPS) positioning fails

- Make sure that you have selected the cable connector of DGPS beacon receiver from Menu (using "1: IN CONNECT" options of "9: INTERFACE").
- Make sure that the baud rate you have set from Menu (using "2: BAUD RATE" options of "9: DGPS") matches the output signal baud rate of DGPS beacon receiver.
- Make sure that you have set the elevation angle from Menu (using "6: ELV ANGLE" options of "3: GPS") is greater than 5 degrees. The correction data sent from the on-shore reference station has the 7.5-degree or larger elevation angle of satellite. If your GPS navigator receives signals from satellite below 7.5 degrees of elevation angle, the DGPS positioning may fail. Set the elevation angle limit to 10 degrees or more.

Unstable signal reception

- The antenna cable may not be connected securely between the antenna and receiver.

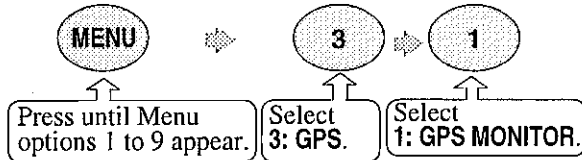

```

3:GPS
1:GPS MONITOR
2 FIX MODE=3D
3 DATUM =WGS-84
4 ANT.H =0000ft
5 DOP MASK=07
6 ELV.MASK=10
  
```

1. Check the HDOP of satellites.

If the HDOP has exceeded 20, NAVIGATOR stops positioning. Also, its positioning accuracy drops as HDOP gets larger in value.

| HDOP | Accuracy |
|----------|------------|
| 1 to 6 | Normal |
| 6 to 12 | Acceptable |
| 12 to 20 | Low |

```

3-1:MONITOR P2.1 1/2
N 04 06 10 13 19 24
20
10
SN 12 10 17 16 08 16
EL 21 22 64 49 15 59
AZ 146 285 020 242 044 154
  
```

2. Check the S/N of each satellite signal.

If elevation angle is greater than 10 degrees, the S/N values should normally be 10 to 20.

3. Check an obstacle that interfere signal reception.

If there is an obstacle between the antenna and satellites, NAVIGATOR cannot receive GPS satellite signals. You must change the antenna position.

Unstable beacon signal reception

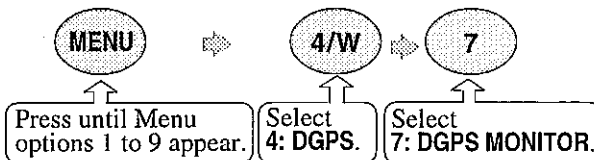

```

4-7-DGPS MONITOR 1/2
FREQUENCY=309.0kHz
BIT RATE =200bps
S/N =10dB
ID NO =0686
DATA AGE =999
HEALTH =0
  
```

- Check the S/N of beacon signal. The S/N values should normally be 6 or more.
- Check the health information

HEALTH indicates health status of reference station.
 0 is best. Reliability degrades as the number increases up to 5.
 6 indicates reference station not monitored.
 7 means reference station not working.

- Make sure there is no obstruction around the receiving antenna and antenna coupler. There should be no metal objects around the receiving antenna and antenna coupler or data cannot be received.
- Check your grounding method. An RF ground may be necessary for reception. Install proper RF grounding if necessary.

Replacing the fuse

- Rotate the fuse case as shown, and pull out and open the case.
- Open the fuse holder cover (that is located inside of fuse case).
- Replace the blown fuse with a new fuse.
- Close the fuse holder cover (until it clicks).
- Rotate and close the fuse case (take care not to damage the cables).

F-7161 2 A

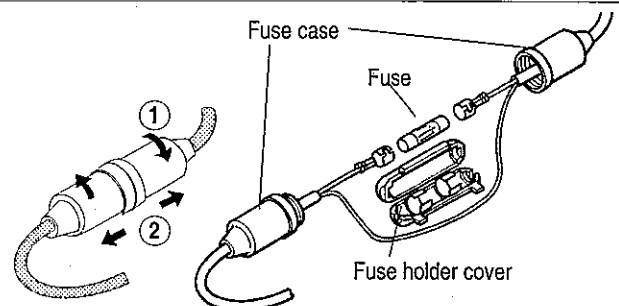

Mounting the waterproof cap

- Face the connector groove upward, and insert it into the end of power connector of display.
- Rotate the coupling clockwise (CW) and fix it.
- Cover the connector with the waterproof cap securely.

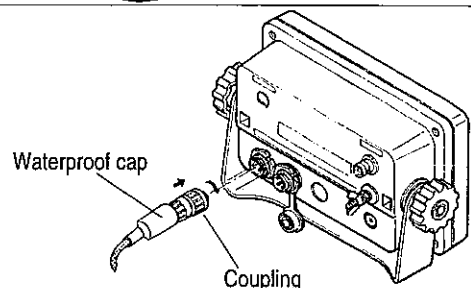

Specifications

Major Specifications

* Specifications subject to change without notice.

| GPS receiver section (Common) | |
|---|--|
| Receiving frequency | 1575.42 MHz \pm 1 MHz |
| Receiving channel | Digital 11-channel parallel/sequential |
| Receiving code | C/A code |
| Sensitivity | Better than -130 dBm (elevation angle: 5° or over) |
| Tracking speed | 200 knots maximum |
| Accuracy | 10 meters RMS (DGPS on), 100 meters 2DRMS (DGS off) |
| (PDOP \leq 3) | Position Velocity |
| | 0.1 knot RMS (DGPS on) |
| Note: Accuracy is subject to change in accordance with DoD civil GPS user policy. | |
| Beacon receiver section (DGPS NAVIGATOR only) | |
| Receiving frequency | 283.5 to 325.0 kHz |
| Channel separation | 500 Hz step |
| Modulation | MSK : 50, 100, 200 bit/second |
| Sensitivity | 2.5 μ V/m or less (at BA-02) |
| Signal detection (S/N) | Better than 6 dB |
| Dynamic range | 92 dB |
| GPS display section (Common) | |
| Display | LCD with backlight (128 x 64 dots, effective picture area: 85.71 x 54.35 mm) |
| Display mode | NAV1, NAV2, NAV3, PLOT, MOB (Man Over Board), MENU |
| Track display | Display range |
| | Usable ground |
| | Plotting interval |
| | Plotting capacity |
| Position data display | Latitude/longitude in increments of 0.0001 minute, converted Loran C LOPs, converted Loran A LOPs, converted Decca LOPs |
| Navigational display | Speed, course, velocity made good/course made good/elapsed time, altitude, distance/bearing/cross track error/course deviation/time to go to waypoint, total time to go and distance on route, DOP value, present time (UTC or LTC), satellite status, beacon receiving status, distance/bearing between two points, MOB display |
| Instant (event) memory | 200 points |
| Waypoint memory | 200 points |
| Route memory | 20 routes (Max. 400 waypoints) reverse trail possible |
| Alarm | Proximity, cross track error, CDI, anchor watch, DGPS, GPS |
| Position compensation | Latitude/longitude, LOPs, Datum |
| Magnetic compensation | Auto or manual |
| Parameters | Loran C LOPs conversion, Loran A LOPs conversion, Decca LOPs conversion, memory of waypoints and name (up to 10 letters), selection of measuring unit (nm,sm,km), antenna height unit (ft, m), antenna height, averaging (smooth) factor, position mode (2D or 3D automatic selection), beacon stations selection |
| Output data format (GPS NAVIGATOR : NMEA-0183 only) | NMEA-0183 (AAM, APB, BOD, BWC, DCN, GGA, GLC, GLL, GSA, GSV, GTD, MSS, ODA, RMB, RMC, Rnn, RTE, SGR, SNU, VTG, WDC, WPL, XTE and ZDA), NMEA 1, NMEA 2, CIF, SHIPMATE 0183, RTCM SC104 (for DGPS, 4800 baud rate) |
| Data output interval | 1 second (CIF, SHIP, and NMEA 1), 3 seconds (NMEA 2), and 1 to 99 seconds selectable (NMEA-0183) |
| Memory protection | By built-in battery |
| Power supply | 10.8 to 41.6 VDC |
| Power consumption | 4.8 W or less (KGP-913D), 3.3 W or less (KGP-913), at 24 VDC |
| Operating temperature | Display unit: - 15° to + 55°C (5° to 131°F) |
| | Antenna unit: - 30° to + 75°C (- 22° to 167°F) |
| GPS display section (DGPS NAVIGATOR only) | |
| Differential | ON, OFF, AUTO |
| Beacon station selection | Auto (requires position information) or manual |
| Beacon station data | User entry (20 stations), beacon almanac data (10 stations), ROM (built-in stations around the world) |
| Operating temperature | Antenna coupler: - 30° to + 70°C (- 22° to 158°F) |

Standard equipment list

Common

| No. | Article | Type | Remarks | Weight/length | Quantity |
|-----|-------------------------------|------------------|---|--|----------|
| 1 | Display unit | KGP-913/GPS-90 | With mounting bracket and vinyl cover | 0.86 kg (1.9 lb) | 1 |
| | | KGP-913D/GPS-90D | With mounting bracket and vinyl cover | 0.96 kg (2.1 lb) | |
| 2 | Antenna unit Antenna cable | GA-08 | For GPS reception, with antenna cable Connected to GA-08/ BNC connector | 0.62 kg (1.4 lb) 10 m (32 13/16 ft) | 1 |
| | | GA-08L | For GPS reception, with antenna cable Connected to GA-08L/ BNC connector | 0.81 kg (1.8 lb) 15 m (49 3/16 ft) | |
| 3 | DC power cable | CW-241 | With 3-pin connector | 1.8 m (5 15/16 ft) | 1 |
| 4 | Fuse | F-7161, 2 A | For spare | | 1 |
| 5 | Truss tapping screw | TPT M5 X 20U | For mounting bracket | | 2 |
| 6 | Operation manual | | | | 1 |

Installation materials: available upon requirement

| | | | | | |
|---|-----------|----------|--------------|--|---|
| 7 | Hose band | 738-1015 | Antenna unit | | 2 |
|---|-----------|----------|--------------|--|---|

DGPS NAVIGATOR only

| No. | Article | Type | Remarks | Weight/length | Quantity |
|-----|----------------------------------|-------------------|---|--|----------|
| 1 | Antenna coupler Antenna cable | BA-02-K/BA-02-S | For beacon reception, with antenna cable Connected to BA-02/ BNC connector | 0.85 kg (1.9 lb) 10 m (32 13/16 ft) | 1 |
| | | BA-02-KL/BA-020SL | For beacon reception, with antenna cable Connected to BA-02-L/ BNC connector | 1.2 kg (2.7 lb) 15 m (49 3/16 ft) | |

Installation materials: available upon requirement

| | | | | | |
|---|-----------|----------|-----------------|--|---|
| 2 | Hose band | 738-1015 | Antenna coupler | | 2 |
|---|-----------|----------|-----------------|--|---|

Options

Common

| No. | Article | Type | Remarks | Weight/length |
|---------------------|------------------|-----------|-------------------------------------|------------------|
| 1 | Printer | KGP-9001A | With power and connecting cable | 1.7 kg (3.8 lb) |
| 2 - 1 - 2 - 3 | Connecting cable | CW-350 | With 6-pin and BNC connectors | 5 m (16 3/8 ft) |
| | | CW-351 | With 6-pin connectors | 5 m (16 3/8 ft) |
| | | CW-352 | With 6-pin connector and lugs | 5 m (16 3/8 ft) |
| 3 | Power rectifier | PS-003A | With two 5A fuses | 2.8 kg (6.2 lb) |
| 4 | AC power cable | VV-2D8 | Both end plain, for power rectifier | 3 m (9 13/16 ft) |
| 5 | Flush mount kit | FMK-1 | Flush mount frame with screws | |
| 6 | Antenna holder | RAH-29 | Ratchet mount | 0.68 kg (1.5 lb) |

DGPS NAVIGATOR only

| No. | Article | Type | Remarks | Weight/length |
|-----|---|----------|---|---------------------------------------|
| 1 | Receiving antenna | RA-14 | 2.45 m, whip | 0.3 kg (0.67 lb) |
| 2 | H-field loop antenna Antenna cable | BA-03 | With antenna cable Connected to BA-03/BNC connector | 1.4 kg (3.1 lb) 10 m (32 13/16 ft) |
| | | BA-03L | With antenna cable Connected to BA-03L/BNC connector | 1.6 kg (3.6 lb) 15 m (49 3/16 ft) |
| | | BA-03S | With antenna cable Connected to BA-03S/BNC connector | 0.99 kg (2.2 lb) 0.5 m (1 5/8 ft) |
| 4 | GPS/H-field beacon antenna Antenna cable | GBA-01 | With antenna cables Connected to GBA-01/BNC connector | 1.9 kg (4.2 lb) 10 m (32 13/16 ft) |
| | | GBA-01L | With antenna cables Connected to GBA-01L/BNC connector | 2.2 kg (4.9 lb) 15 m (49 3/16 ft) |
| | | GBA-01S | With antenna cables Connected to GBA-01S/BNC connector | 1.1 kg (2.5 lb) 0.5 m (1 5/8 ft) |
| 5 | Antenna extension cable | CW-826 | With N-P/BNC connectors For BA-03S/GBA-01S | 0.5 m (1 5/8 ft) |
| | | RG-10U/Y | With N-P connectors For BA-03S/GBA-01S | 20 m (66 ft) |
| | | RG-10U/Y | With N-P connectors For BA-03S/GBA-01S | 30 m (98 7/16 ft) |

Other materials (For BA-03/03L/03S, GBA-01/01L/01S)

| No. | Article | Type | Remarks | Quantity |
|-----|----------------|----------|--|----------|
| 1 | Antenna holder | RAH-23 | Stainless steel made For BA-03/03L/03S, GBA-01/01L/01S | 1 |
| 2 | Hose band | SD-2050 | For BA-03/03L/03S, GBA-01/01L/01S | 1 |
| 3 | Hose band | 738-1015 | For BA-03/03L/03S, GBA-01/01L/01S | 1 |

Outline and Dimensions

Scale differs among drawings.

Antenna unit (GA-08/08L)

Unit: mm (inch)

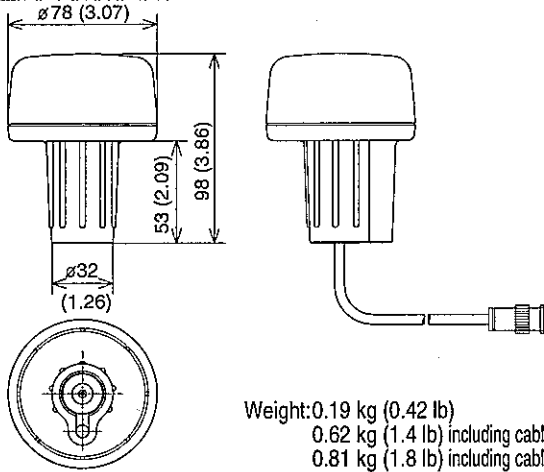

Weight: 0.19 kg (0.42 lb)
 0.62 kg (1.4 lb) including cable (10 m)
 0.81 kg (1.8 lb) including cable (15 m)

Mounting of Flush mount kit (FMK-1)

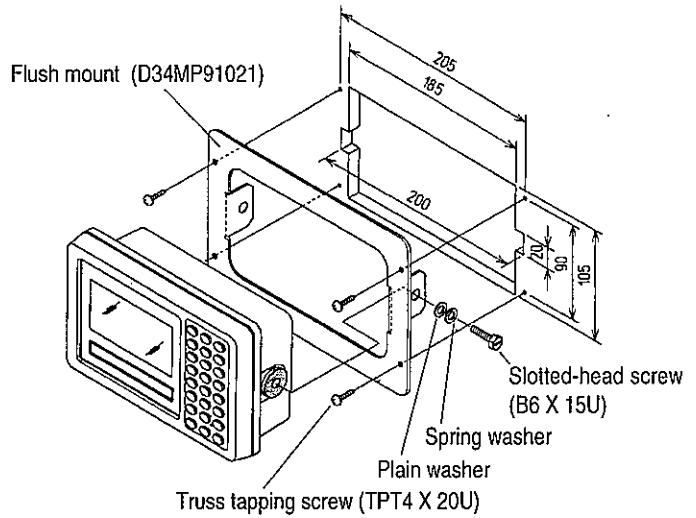

Antenna coupler (BA-02-K/02-S/02-KL/02-SL)

Unit: mm (inch)

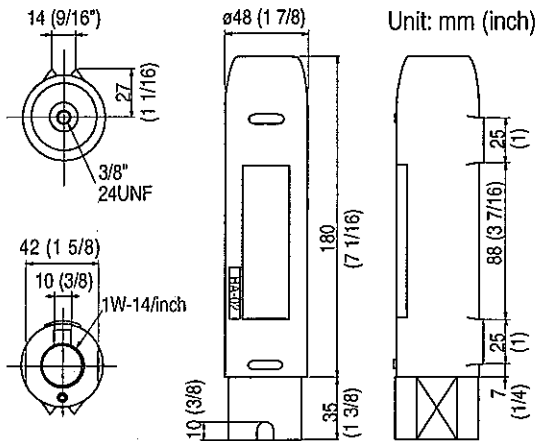

Weight: 0.4 kg (0.89 lb)
 0.85 kg (1.9 lb) including cable (10 m)
 1.2 kg (2.7 lb) including cable (15 m)

Antenna unit (GBA-01/01L/01S, BA-03/03L/03S): Optional

Unit: mm (inch)

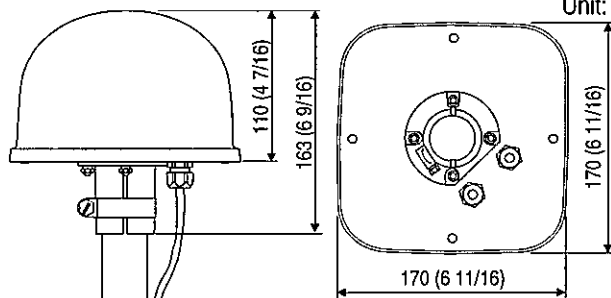

| | | |
|--------------------------|----------------------|-------------------------|
| GBA-01/01L/01S | BA-03/03L/03S | |
| Weight: 0.95 kg (2.1 lb) | 0.92 kg (2.1 lb) | |
| 1.9 kg (4.2 lb) | 1.4 kg (3.1 lb) | including cable (10 m) |
| 2.2 kg (4.9 lb) | 1.6 kg (3.6 lb) | including cable (15 m) |
| 1.1 kg (2.5 lb) | 0.99 kg (2.2 lb) | including cable (0.5 m) |

Display unit

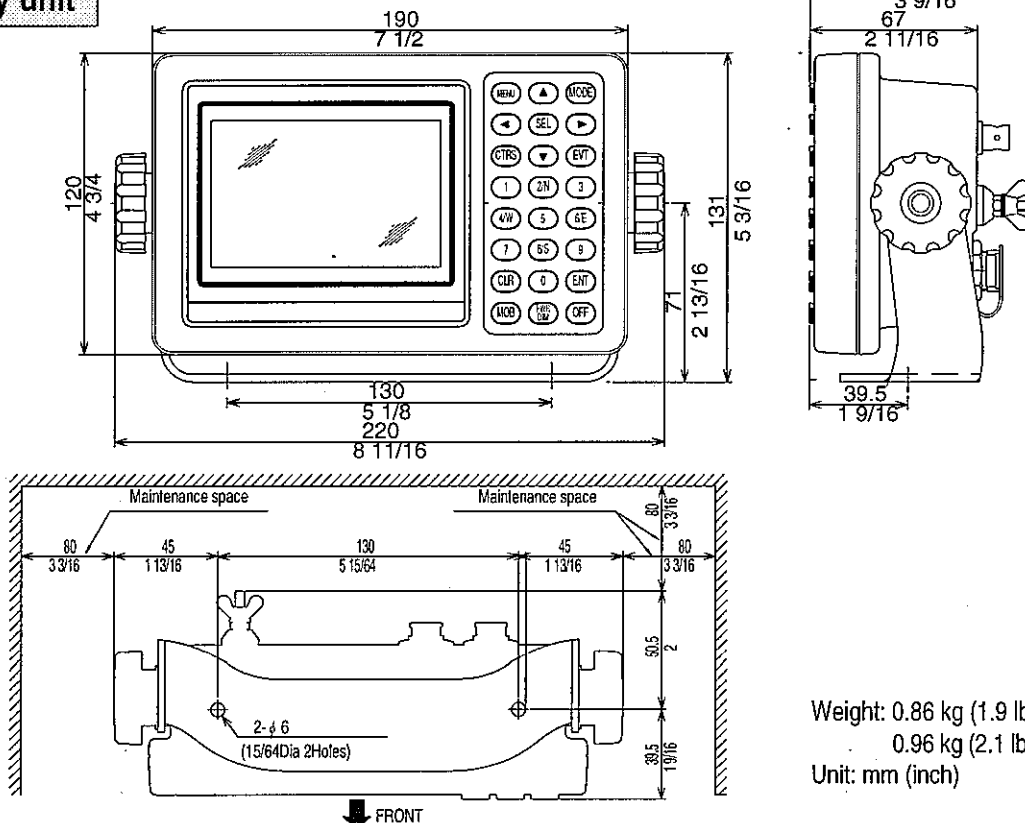

Weight: 0.86 kg (1.9 lb) GPS NAVIGATOR
 0.96 kg (2.1 lb) DGPS NAVIGATOR
 Unit: mm (inch)

Interconnecting diagram: GPS NAVIGATOR

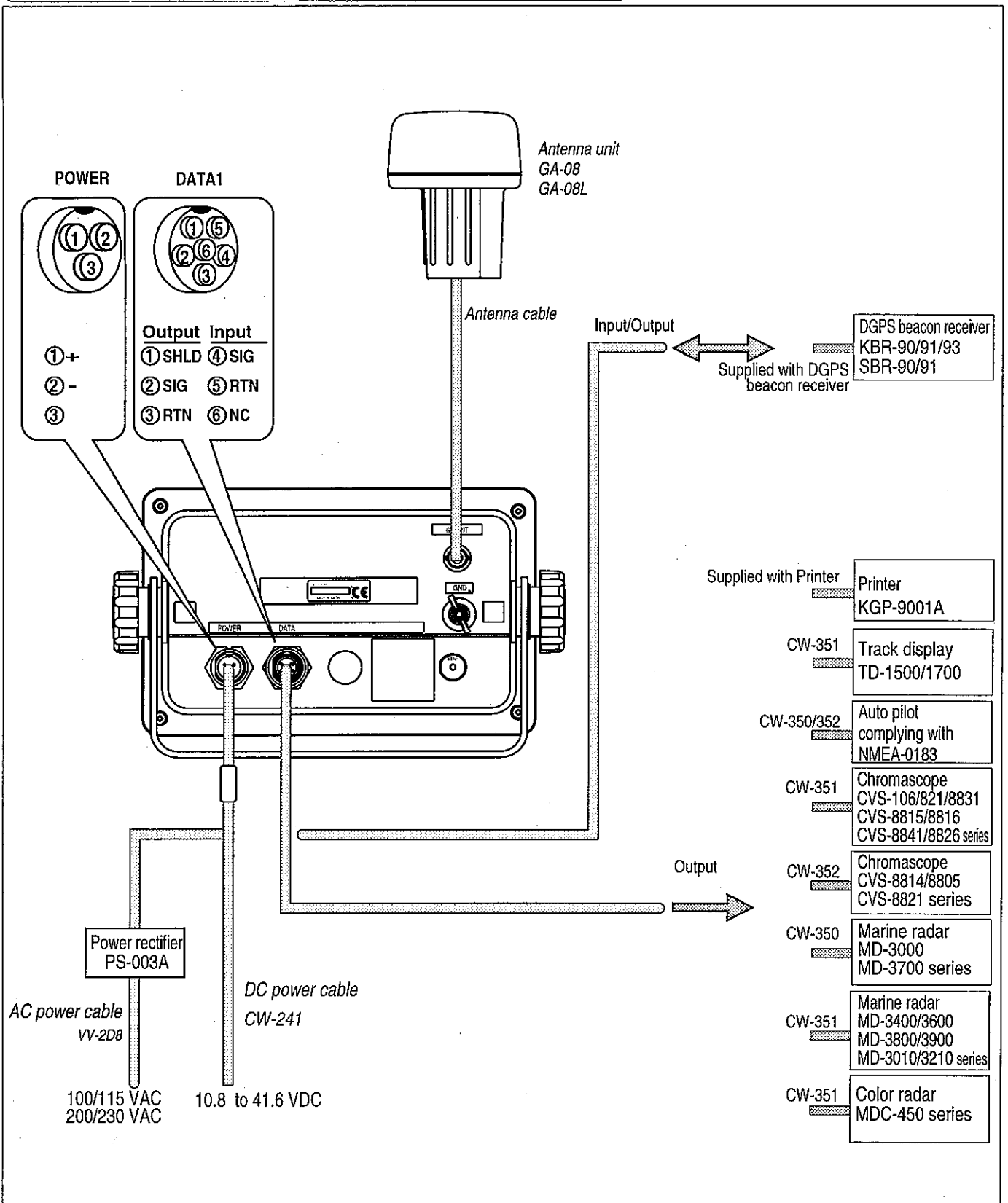

Note: Connection method to the power rectifier varies depending on the given voltage level (100 VAC, 115 VAC, 200 VAC, 230 VAC). For the detail, refer to the attached drawing on the power rectifier, "Outline, dimensions & circuit of the rectifier".

Interconnecting diagram: DGPS NAVIGATOR

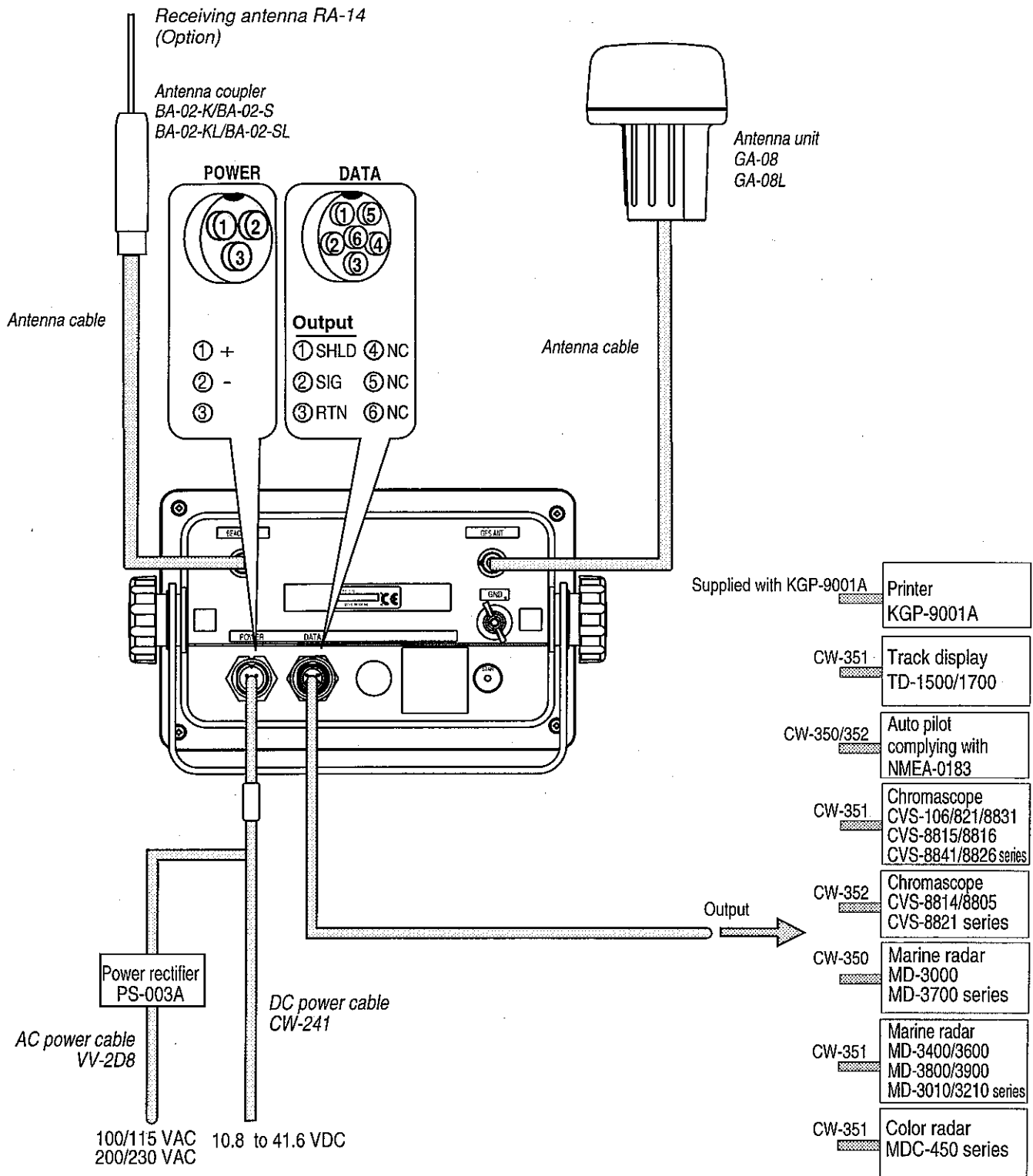

Note: Connection method to the power rectifier varies depending on the given voltage level (100 VAC, 115 VAC, 200 VAC, 230 VAC). For the detail, refer to the attached drawing on the power rectifier, "Outline, dimensions & circuit of the rectifier".

Connection using H-field loop antenna (GA-08/08L and BA-03/03L/03S): Option

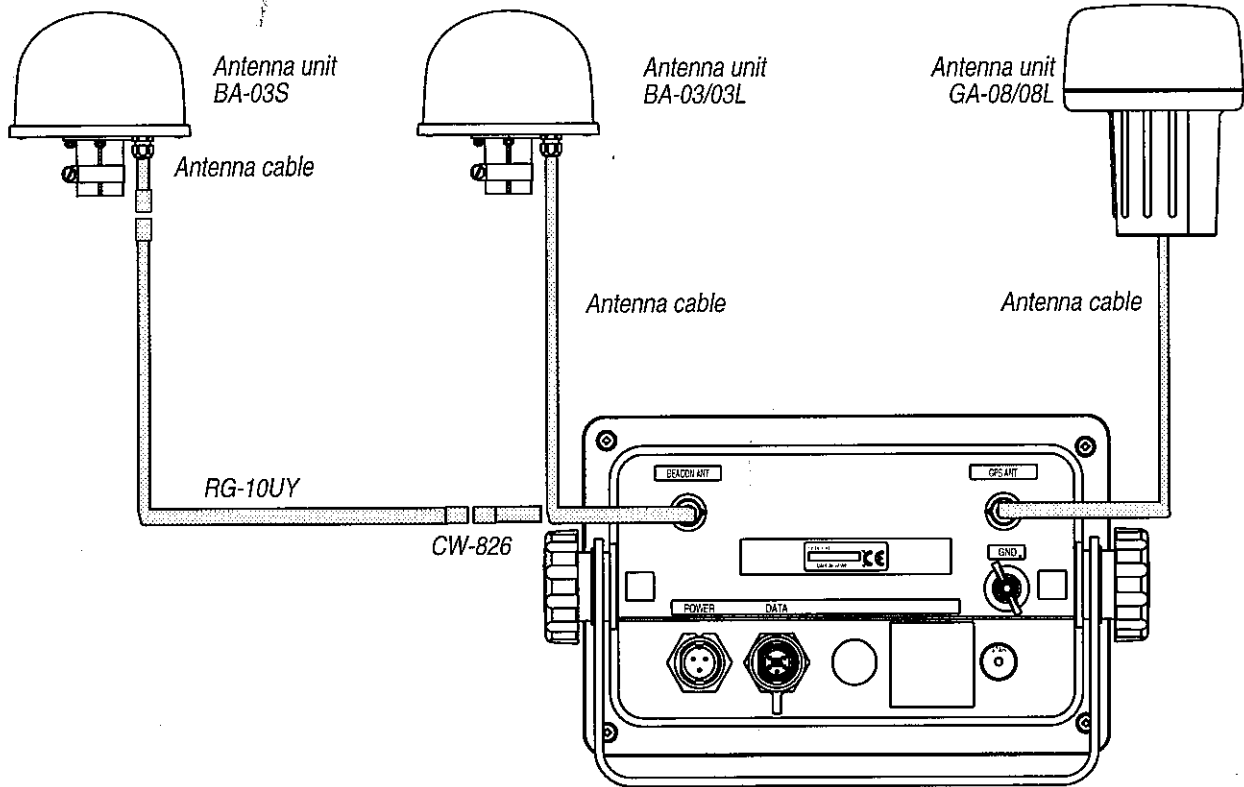

Connection using GPS/H-field beacon antenna (GBA-01/01L/01S): Option

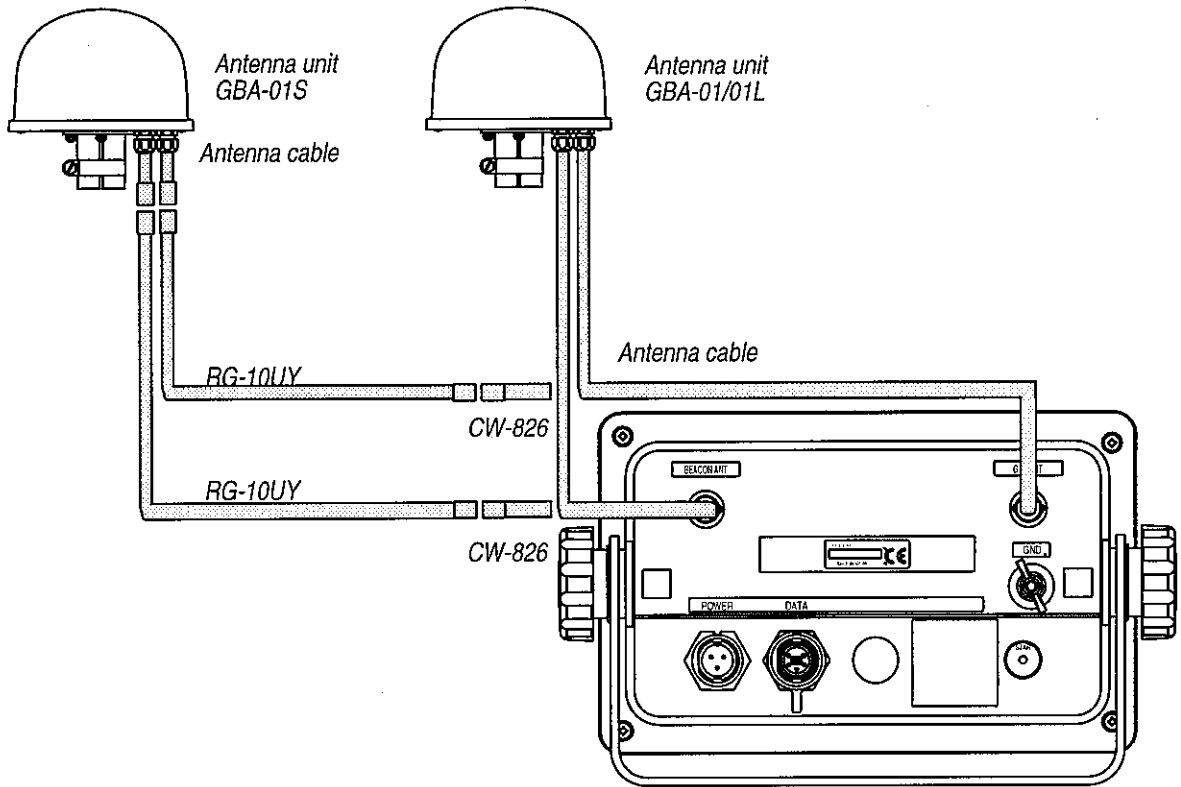

Installing Antenna

Selecting the best site for GPS antenna

Scale differs among drawings.

Make sure to install the antenna unit at a location where nothing shades the antenna of a view above the horizon .

Objects placed above the antenna unit or too close to the antenna unit may cause signal to noise ratio to degrade and shorten measuring time.

- (1) As far away from any metallic objects as possible.
- (2) At least 4 meters (13.2 feet) away from the MF/HF reversed L-type TX antenna, VHF or HF whip antenna.
- (3) At least 1.5 meter (4.9 feet) above the MF/HF reversed L-type TX antenna.
- (4) At least 1 meter (3.3 feet) away from the receiving antenna.
- (5) Outside radar transmitting beam (30° to 40°).
- (6) At least 1 meter (3.3 feet) away from the radar antenna.
- (7) At least 5 meters (16.5 feet) away from the Inmarsat antenna.
- (8) At least 3 meters (9.8 feet) away from the loop antenna.
- (9) At least 0.5 meters (1.6 feet) above the large metal surface.

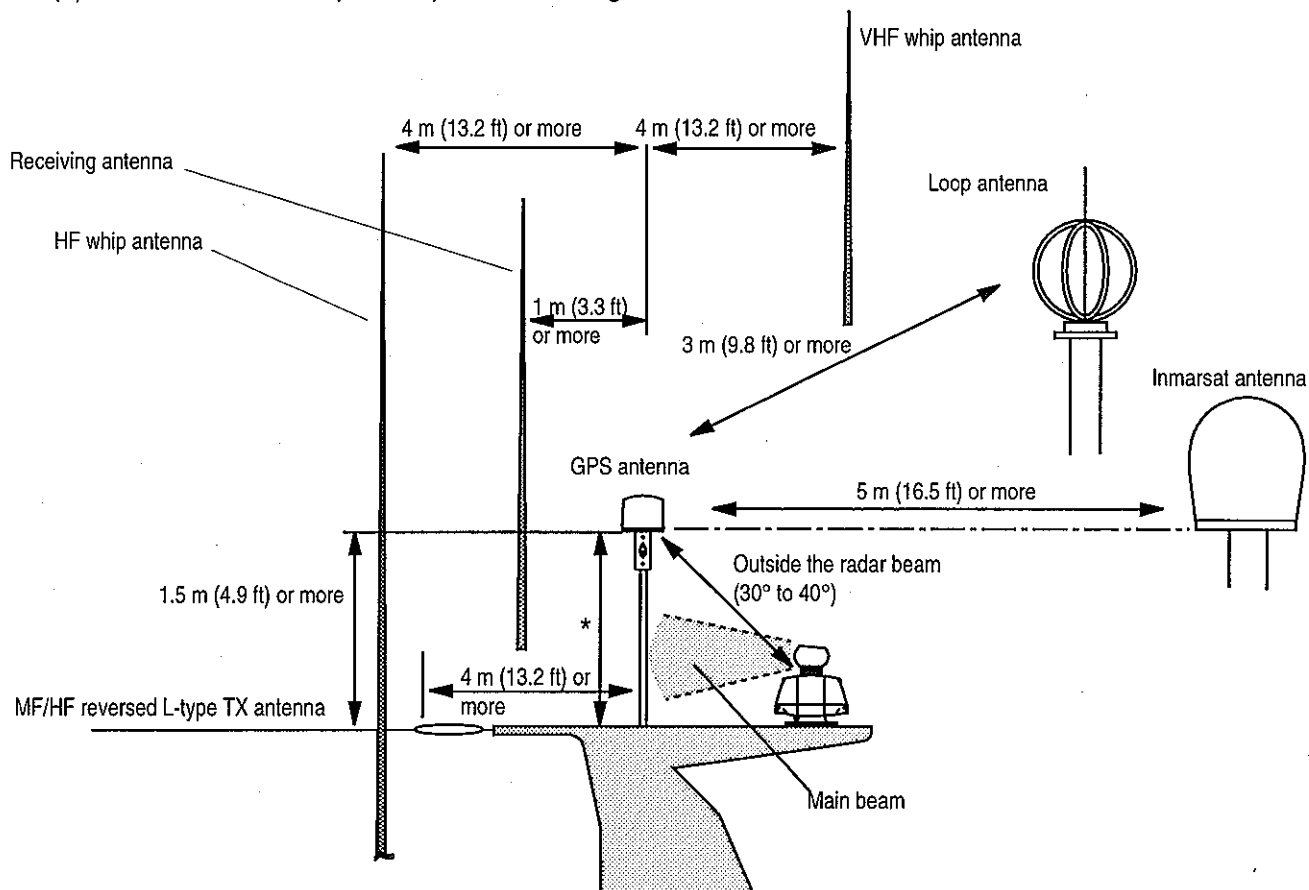

Should you find no place is available under the conditions as described in (1) through (8), then find the largest metal object and set up the antenna as far away as possible.

| Guide line | | |
|------------|-------------------------|------------------|
| Object | Size in diameter | Minimum distance |
| Pole | 10 cm (3 15/16 inches) | 1.5 m (4.9 ft) |
| Pole | 30 cm (11 13/16 inches) | 3.0 m (9.8 ft) |

Cable Connections

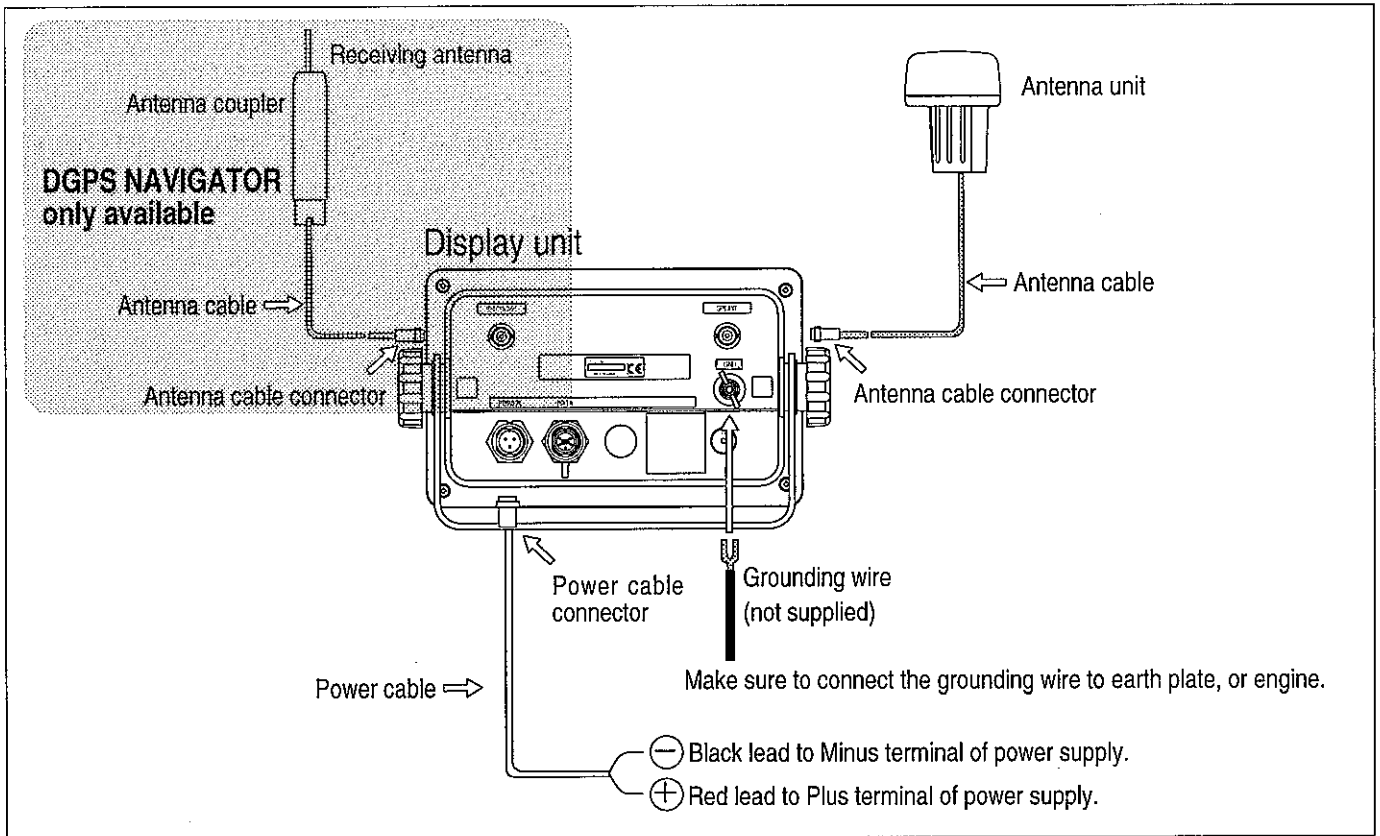

Antenna Installation

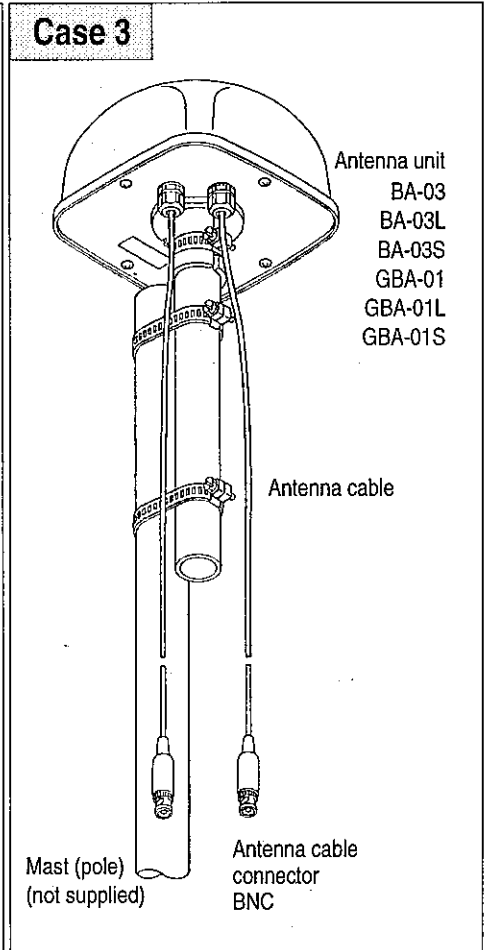
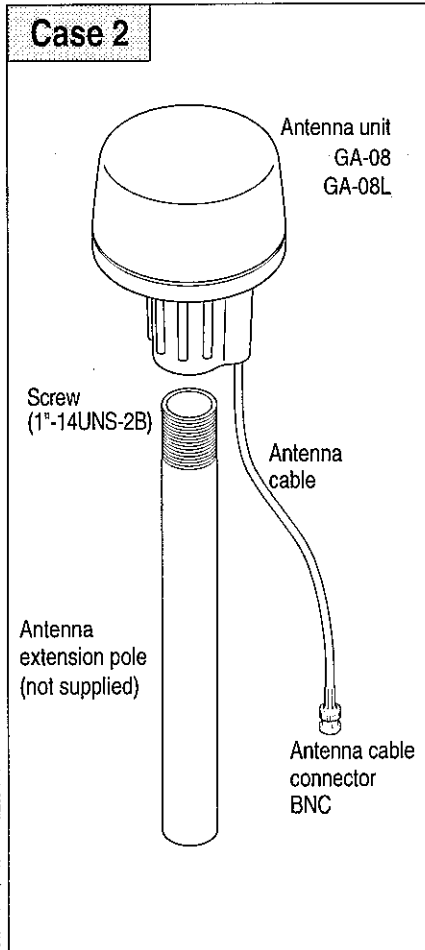
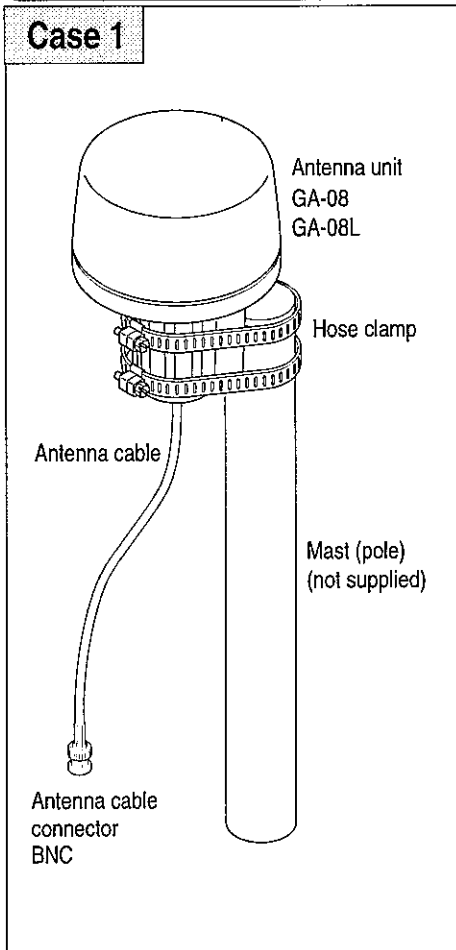

Selecting the best site for Beacon antenna with its coupler

Install the receiving antenna and its coupler at the highest position on the vessel. Do not mount under or inside a place where metal is present. A metallic object between the transmitting station and antenna might not allow reception within the service area.

Notice for installation

As an installation site, select a place free from any metallic objects.

Install the antenna coupler at least one meter away from the receiver or remote display.

An appropriate installation position for the receiving antenna and coupler is as follows according to different types of vessel.

- On a sail boat, an insulated aft stay is usable as an antenna.
- In case of center cabin vessel, install the coupler on a side or on top of the cabin.
- On a power boat, install the coupler on the top or side of the cabin.

Select a place where the antenna can be mounted vertical.

Install the coupler as far away from other antennas, particularly transmitting antennas of intermediate or high frequency. Keep away from the TV set and receiving antenna.

Installation site

Select an optimum position for your boat.

For small fishing boats

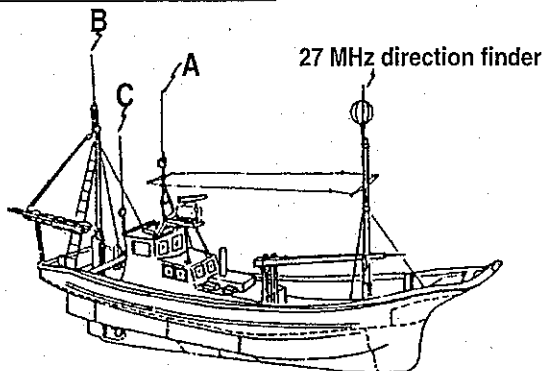

Select an optimum position from A, B, and C below.

Position A (above radar mast)

A short antenna cable suffices.

Position B (on mast)

Installation is possible at a high point, but the antenna cable length may fall short.

Position C (bridge)

A short antenna cable suffices.

For medium to large sized fishing boats

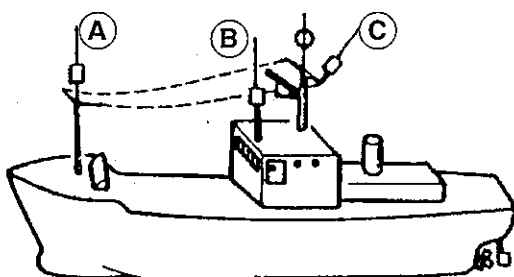

Position A

Mount the antenna at least one meter above the yard and as far away from the transmitting antenna as possible.

Position B

Mount the antenna on the end of the bridge and as far away from any transmitting antennas as possible. Mount the antenna coupler so the horizontal antenna element will be positioned below the middle of the whip antenna.

Position C

Tilt the antenna outward at least two meters away from the loop antenna, even this may slightly affect the bearing measurement on the two MHz band.

Position A and B

Mount on the bridge and as far away from the transmitting antenna as possible.

Position C

Mount at least one meter above the yard and as far away from the transmitting antenna and a loop antenna as possible.

Tilt outward at least two meters away from the loop antenna, even this may slightly affect the bearing measurement on the two MHz band.

Position D

Mount at least one meter above the yard and as far away from the transmitting antenna as possible.

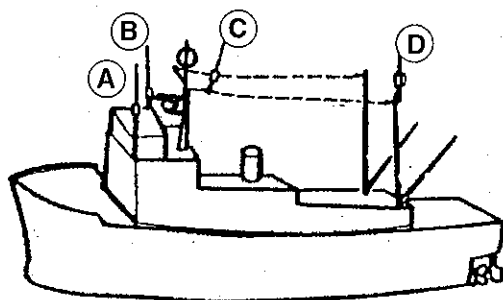

If no mounting position is available matching the above conditions and when the operation is able only where the beacon signal is strong, refer to the following.

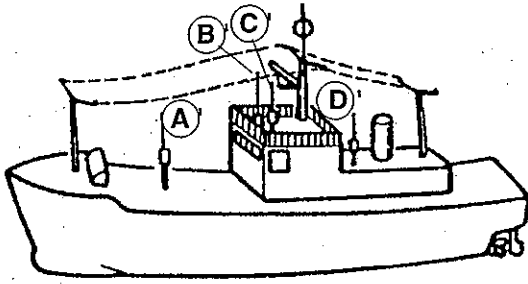

Position(A)

Absolutely avoid any place immediately below the transmitting antenna.

Position(B) and(C)

Separate as far away from the transmitting antenna. Mount the receiving antenna so its top end is located above the transmitting antenna. Separate as far away from the radar mast and other obstacles as possible.

Position(D)

Absolutely avoid any place surrounded by obstacles.

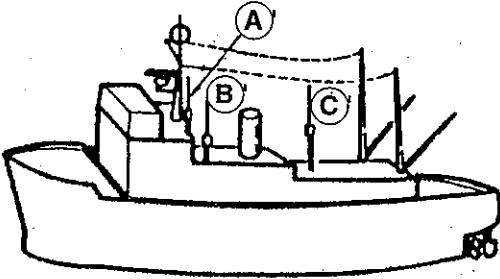

Position(A) and(B)

Separate as far away from any transmitting antenna as possible, and mount the receiving antenna so its top end is located above the transmitting antenna. Separate as far away from the radar mast and other obstacles.

Position(C)

Absolutely avoid any place immediately below the transmitting antenna.

RF ground

Tip 1: Grounding the antenna coupler is essential

The whip antenna used for DPS NAVIGATOR exhibits high impedance, causing the antenna to be sensitive to external noise. To lessen the noise and to make sure better reception of beacon signal, proper grounding of the antenna coupler BA-02 is quite essential.

There is a variance in grounding method according to the material of the hull.

Steel hull: Connect the grounding wire to the nearest grounding point on the hull.

Wooden or FRP hull: Connect the grounding wire from the antenna coupler to the grounding plate attached to the bilge. Make sure the length of the wire is kept shortest as possible.

Tip 2: Grounding method

In general there are three ways for grounding as shown in right figure.

Method 1 (Grounding to another equipment):

This method is considered most convenient and simple to implement, however, in case the noise level is considerable, its effect may be less than expected.

Method 2 (Grounding direct to the bilge):

This method may provide better result than method 1. Make sure the connection is as short as possible and good contact on common grounding point.

Method 3: (Grounding direct to independent bilge ground):

In case you cannot reduce the noise from other source even if the method 1 or 2 is implemented, we recommend the method 3. This approach reduces the common mode noise by applying direct grounding to the bilge, that should be virtually common potential. The independent ship's ground should be located nearest to the antenna coupler, and the ground connection should be as short and thick as possible.

NOTE: The independent ship's ground should be provided with a thick copper plate which is attached to the bottom of the hull. The ground connection must be routed in a shortest distance.

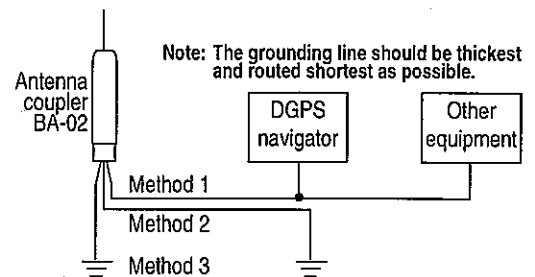

Tip 3. Reducing the noise from other equipment

When you connect DGPS NAVIGATOR to another equipment, the noise can possibly be induced via connection cables from the equipment in operation. To eliminate the noise DGPS NAVIGATOR should be bonded to the equipment to maintain these units at common ground potential. This arrangement may contribute to reduce the noise.

Tip 4. Reducing the noise from dynamo

The noise generated from dynamo can often become a serious interference that worsens the beacon signal reception. As shown in right figure, the noise current flows in two different paths, i.e. Normal Mode and Common Mode, respectively. The noise can be discriminated from other noise source by increasing or decreasing the output of the engine. Should the noise be detected, connect the capacitors as specified in right figure. It is known that the common mode noise can often become a major cause of the interference to the receiver.

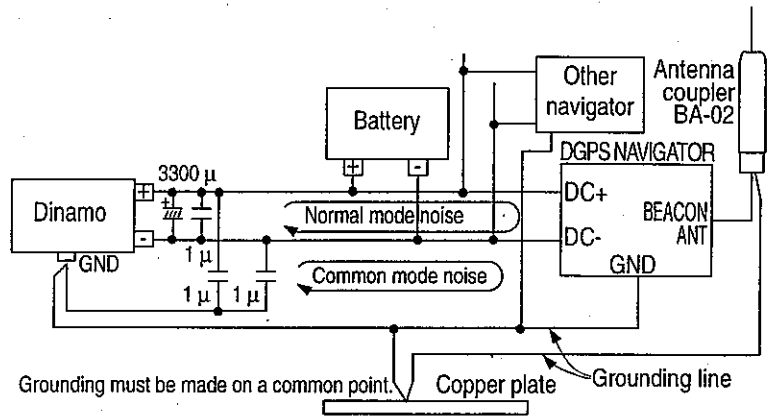

Tip 5. Checking the overall function

When you have implemented the above countermeasures, use the following procedures to verify the modification is effective.

Confirm a reception status of the beacon signal by the S/N ratio shown on the DGPS monitor, which is menu driven. The S/N ratio of more than 6 is acceptable for normal operation.

As the situation on board varies according to a ship, in terms of the material of the hull, cable layout, etc, we recommend to try out a possible combination of the countermeasures described above.

This test method should also be performed in the following conditions on board.

- Ship's engine is stopped.
- Ship's engine is driven at lower revolution.
- Ship's engine is driven at higher revolution.
- The drainage pump is run.
- The ventilation fan in the engine room is operated.
- The fluorescent lamps are turned on.

Receiving antenna and antenna coupler installation

Case 1

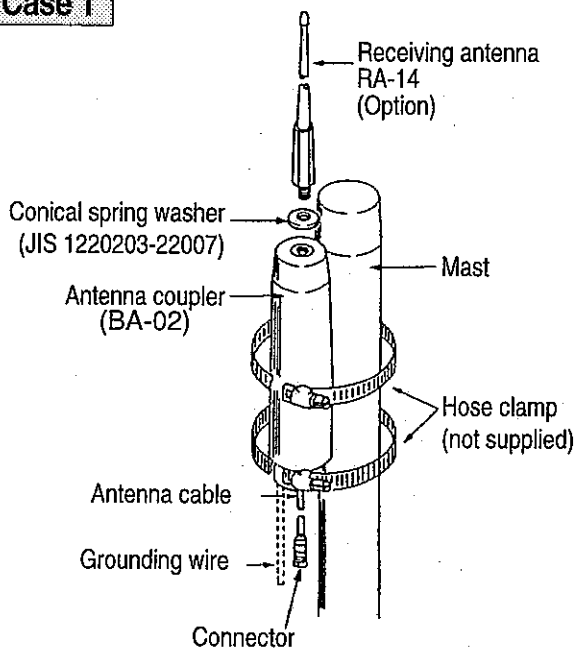

Connect the grounding wire to the ground terminal of the unit or ship's bottom hull steel plate earth.

Case 2

Receiving antenna holding pipe (Screw: W1-14 threads)

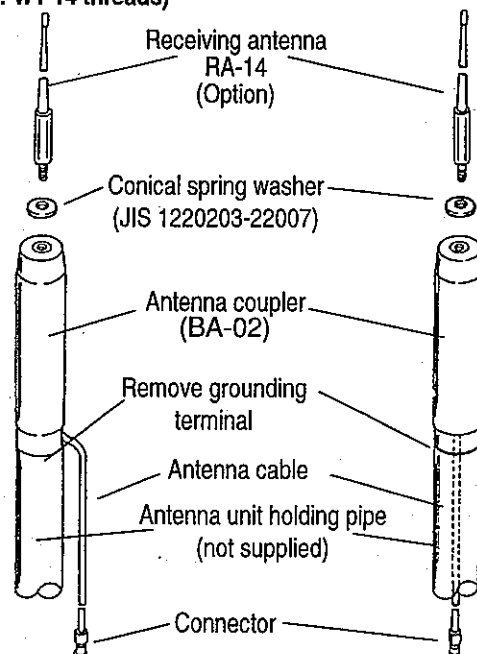

Local Geodetic Systems

The number assigned to each place name is the set values used in the "Selecting a geodetic datum " (page 42).

In alphabetical order

| Name | No. | Name | No. |
|---------------|-----|---------------|-----|
| ALASKA/CANADA | 04 | LIBERIA 64 | 57 |
| ARC 50 | 29 | MAHA 71 | 58 |
| ARC 60 | 30 | MALAYSIA | 23 |
| ARGENTIN | 39 | MALDIVE | 48 |
| ASCENSION | 31 | MARCUS | 35 |
| AUSTRALIAN 84 | 06 | MARSHALL | 82 |
| BAHRAIN | 27 | MASCARENE | 73 |
| BERMUDA | 37 | MIDWAY 61 | 62 |
| BRAZIL | 45 | MOROCCO | 61 |
| CANARY | 68 | NAD-27 | 03 |
| CAYMAN BRAC | 56 | NAD-83 | 10 |
| CHATHAM | 43 | NEW GEORGIA | 46 |
| COCOS | 28 | NEW ZEALAND | 13 |
| COLOMBIA | 38 | NIGERIA | 63 |
| CORVO/FLORES | 65 | OMAN | 67 |
| DIEGO GARCIA | 52 | PARAGUAY | 44 |
| DJAKARTA | 22 | PHILLIPPINES | 19 |
| EAST FALKLAND | 76 | PHOENIX | 40 |
| EAST MALAYSIA | 79 | PITCAIRN | 69 |
| EASTER | 47 | PORTO SANTO | 77 |
| EFATE | 36 | PUERTO RICO | 71 |
| EGYPT | 66 | QATAR | 72 |
| ENGLAND | 20 | ROME 40 | 15 |
| ERITREA | 60 | SALVAGE | 59 |
| ETHIOPIA | 25 | SANTA MARIA | 75 |
| EUROPEAN 50 | 05 | SANTO | 74 |
| EUROPEAN 79 | 14 | SAUDI ARABIA | 17 |
| FAIAL | 78 | SOMALIA | 26 |
| FIJI | 81 | SOUTH AFRICA | 16 |
| FINLAND | 84 | SOUTH AMERICA | 08 |
| FLORIDA | 41 | SOUTH ASIA | 07 |
| GREENLAND | 09 | SOUTH CHILE | 70 |
| GUADALCANAL | 50 | SRI LANKA | 54 |
| GUAM 63 | 49 | ST. HELENA | 34 |
| HAWAII | 21 | SURINAM | 83 |
| HONG KONG 63 | 51 | SWEDEN | 85 |
| ICELAND 55 | 11 | TERN | 33 |
| INDIAN/NEPAL | 18 | TOKYO | 02 |
| IRELAND 65 | 12 | TRINIDAD | 64 |
| IWO JIMA | 32 | TRISTAN | 80 |
| JAPAN | 24 | TUNISIA | 42 |
| JHONSTON | 53 | WGS-72 | 01 |
| KELGUELEN | 55 | WGS-84 | 00 |

In numerical order

| No. | Name | No. | Name |
|-----|---------------|-----|---------------|
| 00 | WGS-84 | 43 | CHATHAM |
| 01 | WGS-72 | 44 | PARAGUAY |
| 02 | TOKYO | 45 | BRAZIL |
| 03 | NAD-27 | 46 | NEW GEORGIA |
| 04 | ALASKA/CANADA | 47 | EASTER |
| 05 | EUROPEAN 50 | 48 | MALDIVE |
| 06 | AUSTRALIAN 84 | 49 | GUAM 63 |
| 07 | SOUTH ASIA | 50 | GUADALCANAL |
| 08 | SOUTH AMERICA | 51 | HONG KONG 63 |
| 09 | GREENLAND | 52 | DIEGO GARCIA |
| 10 | NAD-83 | 53 | JHONSTON |
| 11 | ICELAND 55 | 54 | SRI LANKA |
| 12 | IRELAND 65 | 55 | KELGUELEN |
| 13 | NEW ZEALAND | 56 | CAYMAN BRAC |
| 14 | EUROPEAN 79 | 57 | LIBERIA 64 |
| 15 | ROME 40 | 58 | MAHA 71 |
| 16 | SOUTH AFRICA | 59 | SALVAGE |
| 17 | SAUDI ARABIA | 60 | ERITREA |
| 18 | INDIAN/NEPAL | 61 | MOROCCO |
| 19 | PHILLIPPINES | 62 | MIDWAY 61 |
| 20 | ENGLAND | 63 | NIGERIA |
| 21 | HAWAII | 64 | TRINIDAD |
| 22 | DJAKARTA | 65 | CORVO/FLORES |
| 23 | MALAYSIA | 66 | EGYPT |
| 24 | JAPAN | 67 | OMAN |
| 25 | ETHIOPIA | 68 | CANARY |
| 26 | SOMALIA | 69 | PITCAIRN |
| 27 | BAHRAIN | 70 | SOUTH CHILE |
| 28 | COCOS | 71 | PUERTO RICO |
| 29 | ARC 50 | 72 | QATAR |
| 30 | ARC 60 | 73 | MASCARENE |
| 31 | ASCENSION | 74 | SANTO |
| 32 | IWO JIMA | 75 | SANTA MARIA |
| 33 | TERN | 76 | EAST FALKLAND |
| 34 | ST. HELENA | 77 | PORTO SANTO |
| 35 | MARCUS | 78 | FAIAL |
| 36 | EFATE | 79 | EAST MALAYSIA |
| 37 | BERMUDA | 80 | TRISTAN |
| 38 | COLOMBIA | 81 | FIJI |
| 39 | ARGENTIN | 82 | MARSHALL |
| 40 | PHOENIX | 83 | SURINAM |
| 41 | FLORIDA | 84 | FINLAND |
| 42 | TUNISIA | 85 | SWEDEN |

KODEN

KODEN ELECTRONICS CO.,LTD.
13-24, TAMAGAWA 2-CHOME, OTA-KU
TOKYO 146-0095 JAPAN
TEL: +81 3 3756 6918
FAX: +81 3 3756 6831

<http://www.koden-electronics.co.jp/>